

SHORT WAVE CRAFT

Edited by
HUGO GERNSBACK

IN THIS ISSUE:

HUNGARY'S SHORT WAVE
POLICE NET

THE "HAM'S OWN" S-W RECEIVER

AN ENGLISH RECEIVER OF
SUPERIOR MERITS

AROUND THE WORLD WITH A
15-WATT TRANSMITTER

MULTIPLE RECEPTION ON A SINGLE
SHORT WAVE

HOT CATHODE, MERCURY VAPOR
RECTIFIERS

PRACTICAL HINTS AND HOOK-UPS
ULTRA SHORT WAVES
150 ILLUSTRATIONS
75 HOOK-UPS

ARTICLES BY

Norman B. Krim

E. T. Somerset, G2DT

R. Wm. Tanner, W8AD

Baron Manfred Von Ardenne

A. Binneweg

C. H. W. Nason

Dr. Andre Szentirmay

S. Gleason

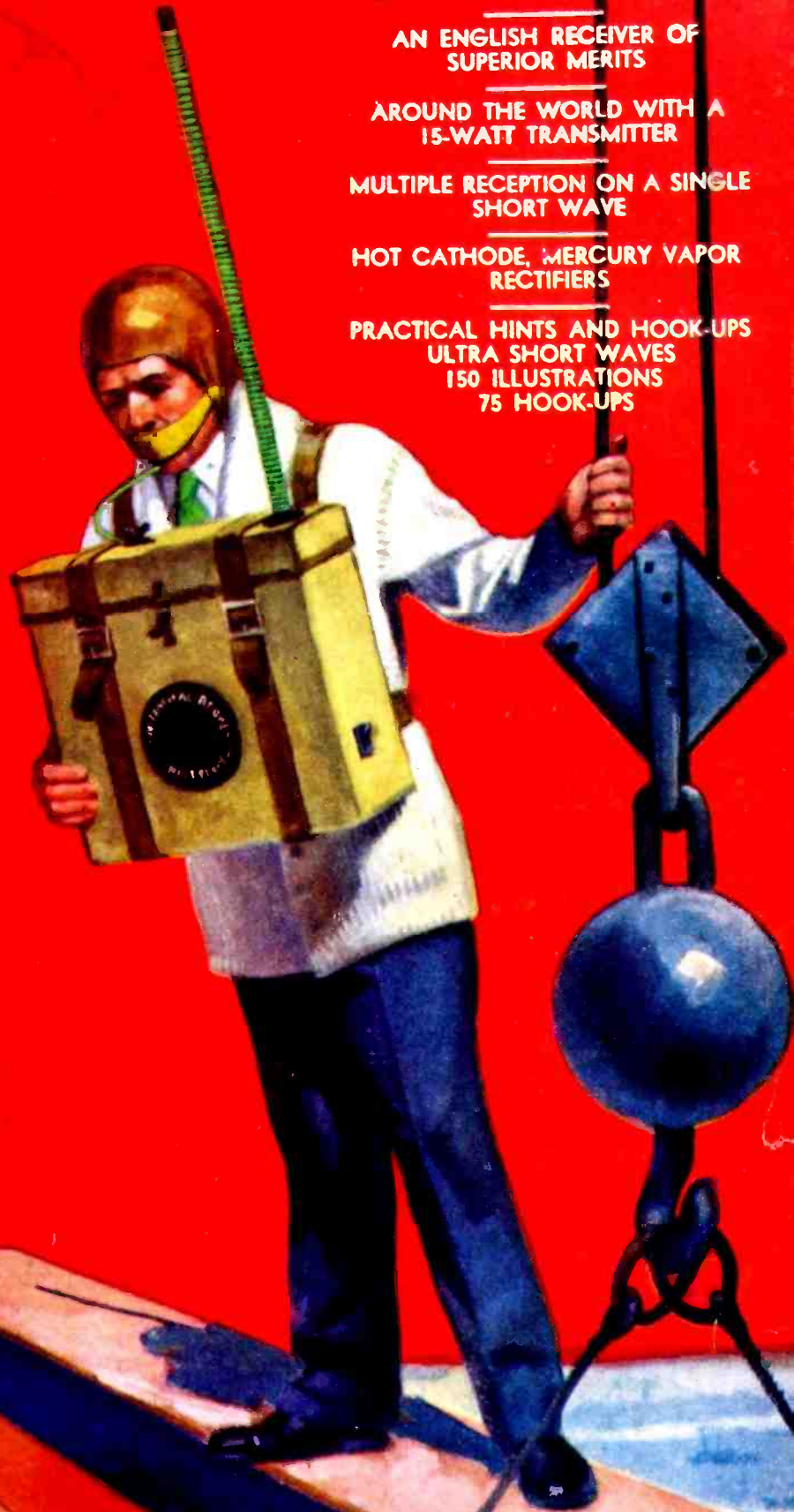

Baird



TELEVISION

A PRACTICAL combination Short Wave, Television and Broadcast Receiver in the simplest possible form. After two years of experiment we now offer the public TELEVISION in the form of a complete kit which can easily be assembled in a very short time and which will work efficiently.

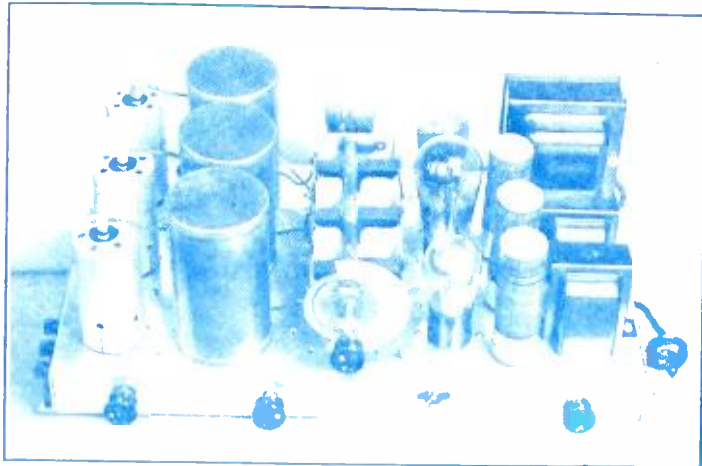

The SHORT WAVE RECEIVER shown here covers a wave length range of 15 to 550 meters and is regenerative for short waves and non-regenerative for Television reception. It employs two stages of screen grid radio frequency, one screen grid detector and three stages of audio amplification, two stages of resistance coupled amplification and a 245 power tube in the third stage, all parts being carefully shielded. This Short Wave Receiver is single dial control and has a minimum of A.C. hum interference especially below 50 meters so that it is possible to use ear phones. Will tune in stations all over the world under normally good conditions with loud speaker volume.

Furnished in kit form complete with blue prints and instruction manual. **Price \$75.00**

Completely assembled in metal cabinet. **Price \$110.00**

(Dealers and jobbers, write for your prices)

The TELEVISION KIT shown includes a special Television 1 15 H.P. Motor, Synchronizing Motor and all accessories including Television synchronizing Amplifier, Lens, Television Lamp and Cabinet; in fact, everything that is necessary for complete Television reception. These parts can be assembled and put into operation in about one hour. This is the only kit which receives horizontally, the perfect method of Television reception to eliminate all distortion and will automatically synchronize on any television signal. Can be easily adjusted for 15, 18 or 60 line pictures. This kit, in conjunction with the above mentioned Short Wave Receiver, will faithfully reproduce all half tone transmissions as the Short Wave Receiver has been especially designed for this work, covering a frequency band of 10 cycles to 10,000 cycles where the ordinary short wave receiver only covers a band of 100 cycles to 5,000 cycles. A transformer coupled receiver will not satisfactorily reproduce a half-tone television picture. All parts absolutely guaranteed.

Complete kit including Television Lamp, Lens and Cabinet. **Price \$80.00**

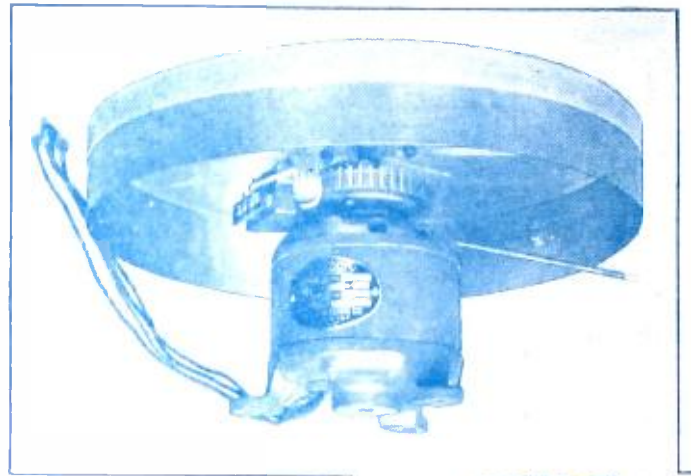

Complete Television Receiver, ready to operate. **Price \$100.00**
(Dealers and jobbers, write for your prices)

OCTOCOILS

The most efficient short wave coils made. Wound with Nos. 12-14-16 and 25 enameled wire on genuine bakelite moulded forms. Will plug into ordinary tube socket. Wave length range 15 to 200 meters.

Price, per set of 4 coils. **\$5.00**



Experimenters, Dealers and Jobbers are invited to write for our prices. Owners and Operators of Television Station W1XAV now on the air with synchronized sound in conjunction with W1XAU. Parts and complete kits on sale at all S. S. Kresge Green Front Stores.

SHORTWAVE & TELEVISION CORPORATION
70 Brookline Avenue Dept. G Boston, Massachusetts

SHORTWAVE & TELEVISION CORPORATION,
70 Brookline Avenue
Boston, Massachusetts.

Dept. G

Please send me the following at special experimenters' prices listed below. Please include deposit to cover cost of shipment:

- No. 25 Complete Short Wave Kit, wave length range 15 to 550 meters, including 2 sets of OCTOCOILS, blue print and construction manual. (Less tubes and cabinet). **\$56.25**
 - No. 26 Television Kit complete with Lens, Television Lamp, Synchronizing Amplifier, Synchronizing Motor and Cabinet. Check 15-18 00 line. **\$60.00**
 - No. 35 Short Wave Receiver, complete in metal cabinet, including 2 sets of OCTOCOILS (Less tubes). **\$82.75**
 - No. 36 Television Receiver, completely assembled in cabinet. Ready to operate in conjunction with a No. 25 or No. 35 Short Wave Receiver. **\$75.00**
 - OCTOCOILS, set of four coils, wave length range 15 to 200 meters. **\$3.75**
- Diagram of 3 tube Tuner sent free on request with stamped self-addressed envelope.

Name Address
State City

SHORT WAVE GROUP. Bi-monthly. Entered as second class matter May 7, 1930, at the post office at Mount Morris, Illinois, under the act of March 3, 1879. Trademarks of E. I. du Pont de Nemours & Co. registered at Post Office, N. Y. C. Text and Illustrations of this magazine are copyrighted and must not be reproduced without permission.

23 26 39 48 56

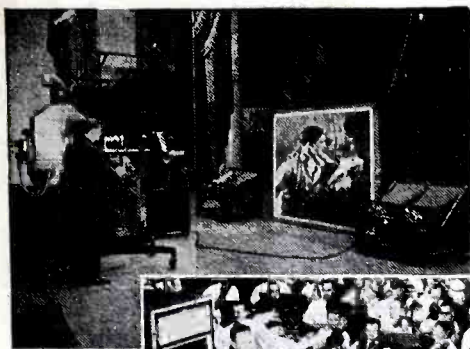

Television--the coming field of many great opportunities--is covered by my course.



Talking pictures--an invention made possible only by radio--offers many fine jobs to well trained radio men.

YOU MUST HAVE NRI TRAINING to be a CERTIFIED RADIO-TRICIAN

My course is the ONLY one that makes you a "Certified RADIO-TRICIAN." The U. S. Government grants me exclusive right to give that distinctive title to all who complete my training. It will mean valuable recognition to you in whatever branch of Radio you follow and will help open the door to bigger pay. Even before you graduate I give you business cards and a "JUNIOR RADIO-TRICIAN" card, which many of my students find helpful in earning money in spare time. My course has helped hundreds of men. It will help you. Send for my free book and you'll see why.

Seldom Under \$100 a Week



"Dear Mr. Smith: For the month of November I made \$577 and for December over \$645, and January, \$465. My earnings seldom fall under \$100 a week. I'll say the N. R. I. (National

Radio Institute) course is thorough and complete. — letter from graduate, E. E. Winborne, 1414 W. 48th Street, Norfolk, Va.

Unlimited Consultation Service

You can keep yourself posted on new developments without extra cost. Radio's change and growth bring new opportunities for the man who understands them. You'll have our whole Staff at your service to keep you informed.



The One Sure Way to BIG PAY in RADIO

Send for my Free Book See how Quickly I Train You at Home to Fill a Big-Pay Radio Job

In Radio more than in any other field, the surest, quickest way to get ahead is through *training!* For Radio is in crying need of more well-trained men. Competition is keen among the untrained fellows but the way is wide open for men who *know* Radio! Moreover, there are plenty of opportunities to earn while you learn—many of my students make \$200 to \$1000 in their spare time while learning. That is why I urge you to mail the coupon below for my free book. It tells about the great money-making opportunities that Radio offers trained men—and how you can learn at home to become a Radio Expert.

Many Earn \$50 to \$100 a Week

Many of my graduates are earning \$50 to \$100 a week. After completing my training you, too, should earn as good or even better pay. Hundreds of fine jobs are opening every year. Broadcasting Stations pay \$1,800 to \$5,000 a year to Radio engineers, operators, and station managers. Radio manufacturers continually need testers, inspectors, foremen, engineers, service men, buyers, for jobs paying up to \$15,000 a year. Shipping companies use hundreds of operators, giving them good pay plus expenses. Radio dealers and jobbers pay \$30 to \$100 a week to trained service men, salesmen, buyers, managers. Talking Movies pay as much as \$75 to \$200 a week to men with Radio training. Another way to make big money is to open a spare time or full time Radio sales and service business of your own. And any day now Television may open the way to a new world of opportunities to men who *know* Radio.

My Free Book Tells All

Get the whole story. Send for my 64-page book of facts on the many opportunities for trained men in Radio today. It has put hundreds of fellows on the road to bigger pay and success. It also contains full information on the "Eighteen Star Features" of my home-study training, including Lifetime Employment Service to graduates. I back my course with a signed agreement to refund every penny of your money if, after completion, you are not satisfied with the Lessons and Instruction Service I give you. Don't let lack of complete training keep you down. Fill in and mail the coupon NOW!

Broadcasting stations offer fascinating jobs, paying from \$1800 to \$6000 a year.



J. E. SMITH, Pres.

Operating on ships gives world-wide travel and \$85 to \$200 a month besides.



Radio factories employ thousands. Salaries for well trained men range from \$1800 to \$5000 a year.

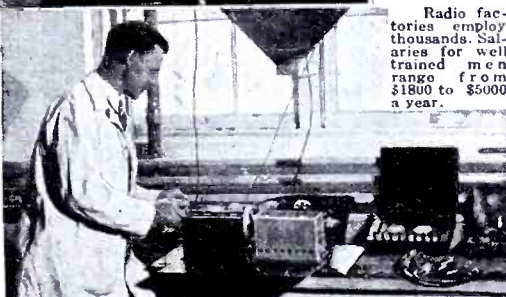

Spare-time servicing pays N.R.I. men \$200 to \$1000 a year.

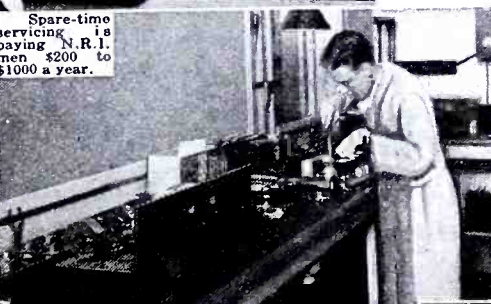

J.E. Smith, Pres., NATIONAL RADIO INSTITUTE Dept. 1FB3 WASHINGTON D.C.

FREE 64 page BOOK



Mail Coupon Today

J. E. SMITH, President National Radio Institute, Dept. 1FB3 Washington, D. C.

Dear Mr. Smith: Send me your free book. I want to know exactly what Radio offers trained men—and what you offer in home-study Radio training. I understand this places me under no obligation and that no salesman will call.

Name.....
Address.....
City..... State.....

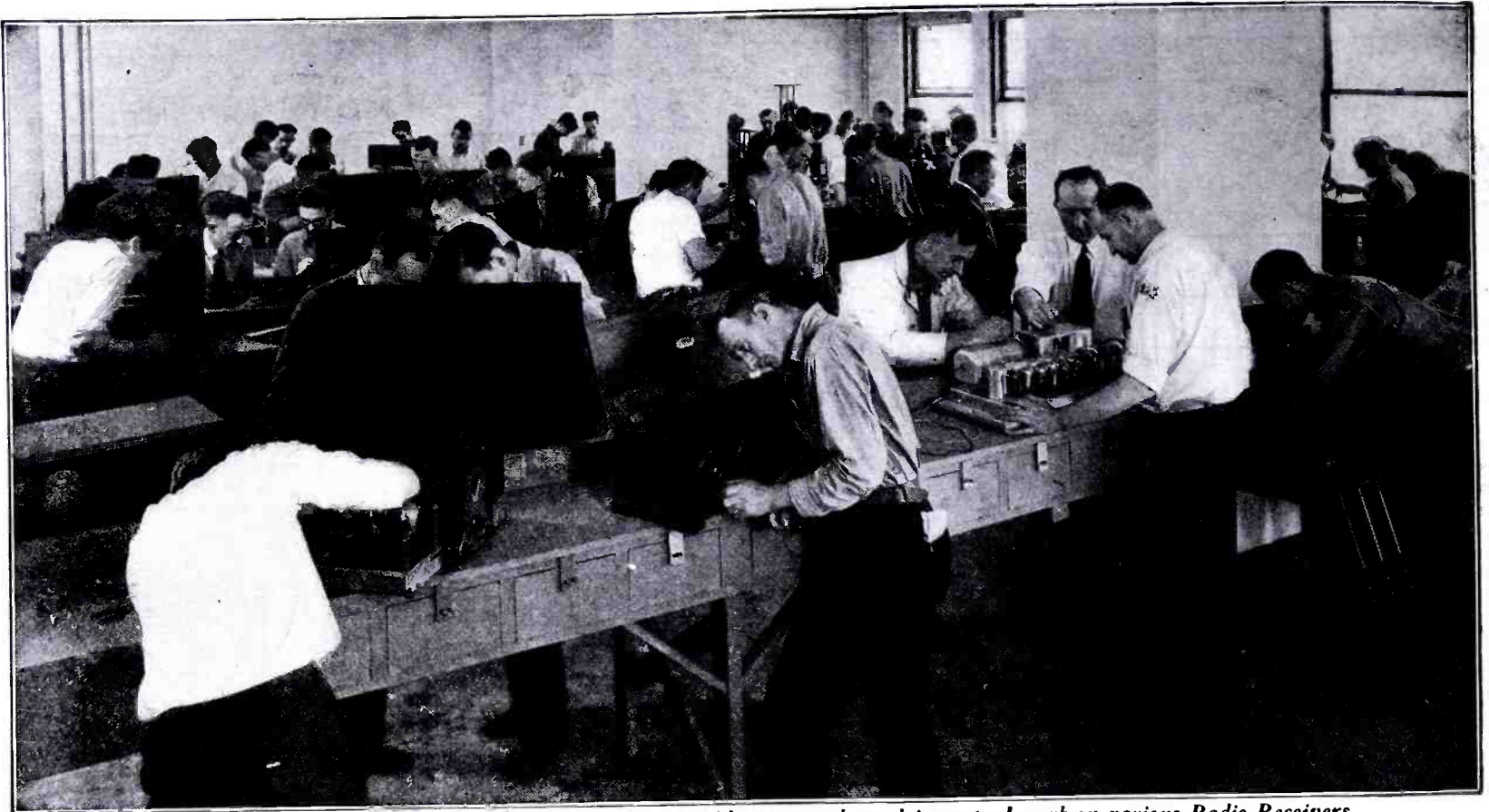

General view of one section of our Service Department, showing students doing actual work on various Radio Receivers

LEARN RADIO-TELEVISION NOT By BOOKS or CORRESPONDENCE-By

Don't spend your life slaving away in some dull, hopeless job! Don't be satisfied to work for a mere \$20 or \$30 a week. Let me show you how to make real money in Radio—the fastest-growing, biggest Money-Making Game on earth!

**Golden Opportunities
Paying \$60, \$70 and Up a Week**

Jobs as Designer, Inspector and Tester paying \$3,000 to \$10,000 a year—as Radio Salesman and in Service and Installation Work, at \$45 to \$100 a week—as Operator or Manager of a Broadcasting Station at \$1,800 to \$5,000 a year—as Wireless Operator on a Ship or Airplane, as a Talking Picture or Sound Expert—THOUSANDS of OPPORTUNITIES LEADING to SALARIES of \$60 A WEEK AND UP!

NO BOOKS -- NO LESSONS

All Practical Work

Coyne is NOT a Correspondence School. We don't attempt to teach you from books or lessons. We train you on the finest outlay of Radio, Television and Sound equipment in any school—on scores of modern Radio Receivers, huge Broadcasting equipment, the very latest Television apparatus,

Talking Picture and Sound Reproduction equipment, Code Practice equipment, etc. You don't need advanced education or previous experience. We give you—right here in the Coyne shops—all the actual practice and experience you'll need. And because we cut out all useless theory, you graduate as a Practical Radio Expert in 10 weeks' time.

**TELEVISION
IS NOW HERE!**

And Television is already here! Soon there'll be a demand for Thousands of Television Experts! The man who learns Television now

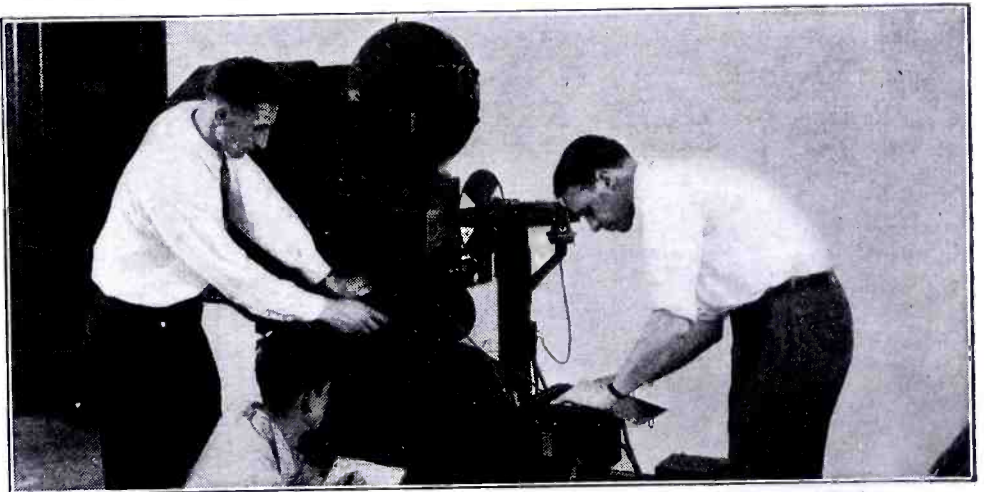

Instructor explaining principles and operation of a Talking Picture Machine

MAIL COUPON ON OPPOSITE PAGE



Students operating our modern Broadcasting equipment. In the rear you can see our Sound Proof Studio Room

TALKING PICTURES in 10 WEEKS

Actual Work - In the Great Shops of Coyne

can make a FORTUNE in this great new field. Get in on the ground floor in this amazing new Radio development! Come to COYNE and learn Television on the very latest Television equipment.

Talking Pictures - A Great Field

Talking Pictures and Public Address Systems offer thousands of golden opportunities to the Trained Radio Man. Here is a great new field of Radio work that has just started to grow! Prepare now for these marvelous opportunities! Learn Radio Sound work at Coyne on actual Talking Picture and Sound Reproduction equipment.

EARN AS YOU LEARN

You get Free Employment Service for life. And don't let lack of money stop you. If you need part-time work while at school to help pay living expenses, we will gladly help you get it. Many of our students pay nearly all of their expenses that way. You can find out everything absolutely free by simply mailing the coupon below.

COYNE IS 32 YEARS OLD

Coyne Training is tested, proven beyond all doubt. You can find out everything absolutely free. How you can prepare for a good job or how you can go into business for yourself and earn from \$3,000 to \$15,000 a year. It costs nothing to investigate! Just mail the coupon for your copy of my big Free book!

H. C. Lewis, Pres. RADIO DIVISION Founded 1899

COYNE ELECTRICAL SCHOOL

500 S. Paulina St., Dept. A1-5H Chicago, Illinois

H. C. LEWIS, President
Radio Div. Coyne Electrical School
500 S. Paulina St., Dept. A1-5H Chicago, Ill.

Send me your Big Free Radio Book and all details of your Special Introductory Offer. This does not obligate me in any way.

Name

Address

City.....State.....

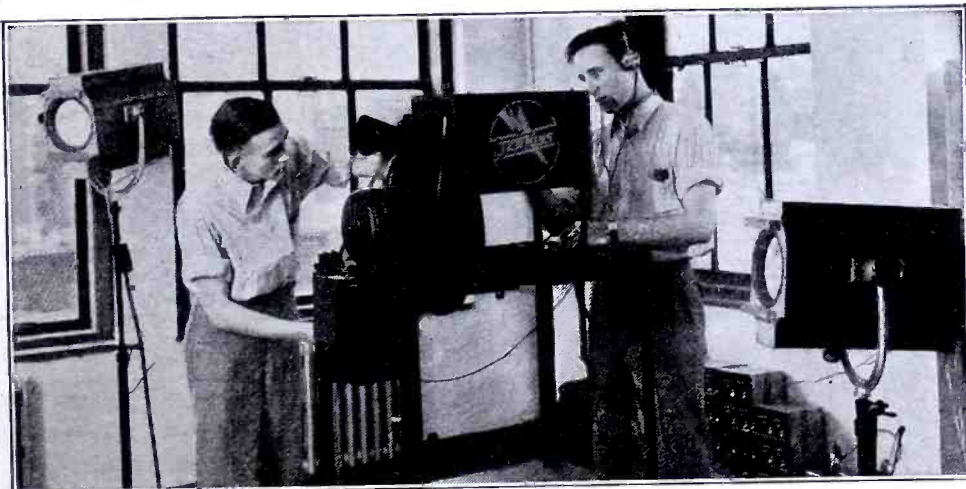

Students operating and adjusting our modern Television Transmitting equipment

FOR BIG FREE BOOK

HUGO GERNSBACK, Editor H. WINFIELD SECOR, Managing Editor

CONTENTS
JUNE - JULY, 1931

In This Issue: Prominent Short Wave Authorities —

Miller — Von Ardenne — Tanner — Somerset — Nason — Binneweg — Dr. Stoye

FEATURES:

| | |
|---|----|
| Editorial | 7 |
| When Hellmut Goes Gunning for Action, by William Burke Miller | 8 |
| 7-Inch Waves Span 21 Miles | 10 |
| Short Wave "Amateurs" Link Trail-Blazers With Base, by Sterling Gleason | 12 |
| Seven-Meter Radio Used on English Tanks | 15 |
| Two or More Programs on a Single Ultra-Short Wave, by Baron Manfred Von Ardenne | 16 |
| Short Wave Converter With "B" Supply Built-In, by Jacob P. Lieberman | 18 |
| How Short Waves Cut Crime in Hungary, by Dr. Andre Szentirmay | 20 |
| Results of International Short Wave Test, by A. J. Green, President International Short Wave Club | 22 |
| A Single Control, Short Wave Receiver, by R. William Tanner, W8AD | 24 |
| The "Ham's Own" Receiver, by Norman B. Krim .. | 26 |
| Investigations in Ultra-Short Waves, by Dr. Karl Stoye | 28 |
| Getting Started on 5 Meters, by E. T. Somerset, G2DT | 30 |
| Short Waves Outwit the Oyster, by S. R. Winters .. | 33 |
| Around the World With a 15-Watt Transmitter, by A. Binneweg, Jr. | 34 |
| Mercury Vapor Rectifiers and How to Use Them, by C. H. W. Nason | 40 |
| The DeForest Short Wave Receiver | 42 |

SHORT WAVES FOR THE BROADCAST

LISTENER:

| | |
|--|----|
| Short Wave Converter With "B" Supply Built-In .. | 18 |
| The Leutz Short Wave Converter | 19 |

| | |
|---|----|
| The "Egert" All-Wave Receiver, by Joseph I. Heller, E.E. | 44 |
| The Walker Super-Converter | 58 |

SHORT WAVE RECEIVERS:

| | |
|---|----|
| Fine Results With Tapped Coils, by Roderick Berry (Commercial Radio Operator) | 23 |
| A Single Control Short Wave Receiver, by R. William Tanner, W8AD | 24 |
| The "Ham's Own" Receiver | 26 |
| Ultra-Short Wave Receiver | 28 |
| 5-Meter Ultra-Audion Receiver | 30 |
| Superior Short Wave Receiver Used at G2DT | 39 |
| De Forest Short Wave Receiver | 42 |
| The "Egert" All-Wave Super-Heterodyne Receiver .. | 44 |
| Portable "Suitcase" Transmitter and Receiver | 46 |
| What Short Wave Receiver Should I Build? by Rolf Wigand | 48 |
| 2-Volt Short Wave Receiver, by John Carter | 50 |
| Dial Spreader for Amateur Bands | 58 |

SHORT WAVE TRANSMITTERS:

| | |
|--|----|
| 7-Inch Ultra-Short Wave Transmitter | 10 |
| Hints On the Beam Antenna | 23 |
| 5-Meter Transmitter | 30 |
| 15-Watt Transmitter Details | 34 |
| Mercury Vapor Rectifiers—How to Use Them | 40 |
| Portable "Suitcase" Transmitter | 46 |

MISCELLANEOUS:

| | |
|--|----|
| Ultra-Short Wave Department | 28 |
| Among the Hams | 52 |
| Short-Wave Stations of the World-Directory | 54 |
| Short Wave Question Box | 56 |
| When to Listen In, by Robert Hertzberg | 73 |

IN OUR NEXT ISSUE

The Vacuum Tube Voltmeter and How to Use It, by C. H. W. Nason
 A Super-Sensitive Receiver for the Reception of Short Waves, by Thomas A. Marshall, Famous U. S. Navy Short Wave Expert
 Economical Modulators for Amateur Radio Phone Transmitters
 Transmitter Tubes and Short Wave Problems, by Allen B. Du Mont
 Europe Spans the Atlantic on Short Waves, by Marcellus Gernsback

"P.C.J." Holland's Short Wave Voice "Heard Around the World"—With Photos of Transmitter and Aerials
 Andy Sannella, Broadcast Entertainer Becomes "Ham" Operator—and Likes It
 Working the 56 MC. Band, by Harry D. Hooton, W8BKV
 Ultra-Short Wave Condensers, by Dr. Karl Stoye
 Improving Operation of the Super-Short Wave Converter, by R. Wm. Tanner, W8AD
 Practical R.F. Choke Construction, by A. Binneweg, Jr.
 Transmitting Aerials and How to Couple to Them, by A. R. Haidell

OUR COVER — Illustrates one application of portable short wave broadcasting set described in article "When Hellmut Goes Gunning for Action." See page 8.

SHORT WAVE CRAFT—Bi-monthly. Entered as second class matter May 7, 1930, at the post office at Mount Morris, Illinois, under the act of March 3, 1879. Trademarks and copyrights by permission of H. Gernsback, 98 Park Place, N. Y. C. Text and illustrations of this magazine are copyright and must not be reproduced without permission. SHORT WAVE CRAFT is published on the 15th of every other month. Six numbers per year. Subscription price is \$3.00 a year in the United States and possessions. Canada and foreign countries, \$3.50 a year. Single copies 50c. Address all contributions for publication to Editor, SHORT WAVE CRAFT, 96-98 Park Place, New York, N. Y. Publishers are not responsible for lost manuscripts. Contributions cannot be returned unless authors remit full postage. SHORT WAVE CRAFT is for sale at all principal newsstands in the United States and Canada. European agents: Brentano's, London and Paris. Printed in U. S. A. Make all subscription checks payable to Popular Book Corporation.

COPYRIGHT, 1931, BY H. GERNSBACK
 Published by **POPULAR BOOK CORPORATION**
 H. GERNSBACK, President - H. W. SECOR, Vice-President
 Publication Office, 404 N. Wesley Avenue, Mount Morris, Ill.
 Editorial and General Offices, 96-98 Park Place, New York, N. Y.

KEEP STEP WITH RADIO PROGRESS!

RADIO is one of the real marvels of this modern age. Its development has been phenomenal. It is growing, changing, evolving new principles which require constant study. The demand is for technically trained men—men who keep pace with the unfolding revelations of this mighty and promising industry.

The International Correspondence Schools Course in Radio, prepared and constantly supplemented by outstanding authorities in the field, is specifically designed to meet the requirements of the radio industry for technically trained radio men. The manufacturer, the distributor, the dealer, Communication and Steamship Companies, the U. S. Government, all insist upon up-to-date, expert training. Recognized for its completeness and practicability, an I. C. S. Radio Course provides this training.

Authorities responsible for the preparation of the I. C. S. Radio Course include: H. H. Beverage, Radio Corporation of America; George C. Crom, American Transformer Company; Keith Henney, author of "Principles of Radio"; Malcom

E. Gager, Instructor at the Massachusetts Institute of Technology; E. V. Amy, consulting radio engineer, formerly with R. C. A.; H. F. Dart, authority on radio tubes; Julius C. Aceves, consulting radio engineer, formerly of Columbia University, and others.

The I. C. S. Radio Course is complete, from the foundational principles of radio to the most advanced stages, thoroughly and scientifically covering every department of this vast industry. It is a modern education in radio, a valuable guide of advancement for men engaged professionally in the radio business. Experimenters will find the I. C. S. Radio Course extremely useful. A thorough understanding of the principles underlying radio communication as presented in the Course will lead to more intelligent undertakings, more systematic work, and more fruitful results. Ample material for experimentations is now available in the ultra-high frequency field and in television.

Mark and mail the coupon. We will send you all details. This act may be the real beginning of your career in radio!

INTERNATIONAL CORRESPONDENCE SCHOOLS,
Box 2879, Scranton, Penna.

Without cost or obligation, please tell me all about the
COMPLETE RADIO COURSE

Name
Street Address
City..... State.....

If you reside in Canada, send this coupon to the International Correspondence Schools Canadian, Ltd., Montreal, Canada.

WORLD'S BEST RADIO BOOKS



ORDER DIRECT FROM THIS PAGE

WE herewith present to the readers of **SHORT WAVE CRAFT** the most complete collection of recent important radio books. We have, after an exhaustive study, selected these volumes because they represent the foremost radio books of their kind in print today. There is such a great variety that we are sure it will satisfy any taste as well as any requirement that the student of radio might have.

We publish no catalogue and ask you to be kind enough to order direct from this page. Prompt shipments will be made to you direct from the publishers. We merely act as a clearing house for a number of radio book publishers and **OUR PRICES ARE AS LOW OR LOWER THAN WILL BE FOUND ANYWHERE.** Prompt shipments will be made.

Remit by money order or certified check. If you send cash, be sure to register it. If you wish to get any other radio book, please write us.

EXPERIMENTAL RADIO, by R. R. Ramsey, Professor of Physics, Indiana University. Cloth covers, size 7½x5½". 256 pages, 168 illustrations. Price, postpaid **\$2.75**

This book by Professor Ramsey is written in the nature of an experimental radio course and contains 128 experiments, illustrated and described in a clear and interesting style. The experiments cover such valuable subjects as: A test on a loud speaker; the impedance of coils; construction of a filter, screen grid tube; beat note audio oscillator; etc.

PRINCIPLES OF RADIO COMMUNICATION, by J. H. Morecroft, Prof. of Electrical Engineering, Columbia University. Cloth covers, size 9½x6", 988 pages. Profusely illustrated. Price **\$7.50**

A radio classic, indeed, is Professor Morecroft's very complete text-book which covers such important radio phenomena as: the action in condensers; self and mutual induction in a circuit; phase and phase difference; effect of condensers and coils on wave shape; resonance frequency of coupled circuits; skin effect in coils; antenna resistance; transformers; vacuum tubes; radio frequency alternators; modulation and circuits; amplifiers and filters.

RADIO TRAFFIC MANUAL AND OPERATING REGULATIONS, by R. L. Duncan and C. E. Drew. Flexible covers, size 9x6", 186 pages. Price **\$2.00**

This valuable handbook starts off with instructions on how to learn the code in considerable detail, with a list of abbreviations. Then comes operating rules and regulations of the Radiomarine Corporation of America with operators' report forms; followed by the rules of the International Radiotelegraph Convention; the United States Radio Act of 1927; the Ship Act of 1912; etc.

PHOTOCELLS AND THEIR APPLICATION, by V. K. Zworykin, E.E., Ph.D., and E. D. Wilson, Ph.D. Cloth covers, size 5½x8", 210 pages, 97 illustrations. Price **\$2.50**

Photocells today occupy a very important place in radio and talking pictures, as well as other branches of applied science, and these two experts have provided the very latest information as to the action taking place in various types of photocells. The theory on which these different cells operate, including color sensitivity, together with amplifier and scanning discs used in picture as well as television transmission, etc.

PRINCIPLES OF RADIO, by Keith Henney, M.A. Cloth covers, size 8x5½", 478 pages, 306 illustrations. Price **\$3.50**

The author is well known in radio and he has here provided a very complete and clearly written discussion of radio circuits and apparatus, including such important topics as: condensers; transformers; determination of inductance;

vacuum tube action, including Screen Grid and Pentode; wave meters, their calibration and use; modulation; amplifiers; long wave receivers; and different types of rectifiers.

HOW TO PASS U. S. GOVERNMENT RADIO LICENSE EXAMINATIONS, by R. L. Duncan and C. E. Drew. Flexible covers, size 9½x7", 170 pages, 92 illustrations, appendix. Price **\$2.00**

The authors are thoroughly conversant with their subject and all of the most important information including hook-ups; types of antennae and receivers with wiring diagrams of both small and large receivers and transmitters of commercial type, including ship sets are given.

RADIO RECEIVING TUBES, by Moyer and Wostrel. Cloth covers, size 7½x5½", 298 pages, 181 illustrations. Price **\$2.50**

No radio student or operator can do without this authoritative book on the radio vacuum tube. The various chapters include construction of vacuum tubes; electrical fundamentals; elementary action taking place in the vacuum tube, with graphs; reactivation of tubes; testing of tubes including determination of amplification factor; plate resistance; grid resistance, etc.

PRACTICAL RADIO—INCLUDING THE TESTING OF RADIO RECEIVING SETS, by James A. Moyer, S.B., A.M., and John F. Wostrel. Cloth covers, size 8x5", 378 pages, 223 illustrations. Price **\$2.50**

Everyone will find this volume of the utmost practical value as the authors have explained in text and diagrams, for the practically-minded student, such interesting subjects as telephone receivers and crystal sets; various types of aerials; current sources for vacuum tubes; audio and radio frequency amplification with hookups; loud speakers and how they work; various radio receiving sets with diagrams and just how they work.

PRACTICAL RADIO CONSTRUCTION AND REPAIRING, by J. A. Moyer, S.B., A.M., and J. F. Wostrel. Cloth covers, size 8x5", 354 pages, 163 illustrations. Price... **\$2.50**

This handbook is one that every radio set tester and general student will want to read carefully. These experts have given a very complete description of instruments used to test and repair modern radio sets, together with complete diagrams of many modern receiving sets, with explanations on how to test the radio and audio frequency stages for faults.

ELEMENTS OF RADIO COMMUNICATION, by Professor John H. Morecroft. Cloth covers, size 9x6", 270 pages, 170 illustrations. Price... **\$3.00**

Professor Morecroft explains in an authoritative and clear manner such important radio phenomena as current flow in circuits containing capacity and inductance; propagation of radio waves; vacuum tubes as detectors and amplifiers; fading of radio waves and its causes; neutralization; superheterodynes for short waves, etc.; audio frequency amplifiers; how filters work, etc.

RADIO TELEGRAPHY AND TELEPHONY, by R. L. Duncan and C. E. Drew. Cloth covers, size 9½x6", 950 pages, 468 illustrations. Price **\$7.50**

This 950 page book forms indeed a most complete treatise on radio facts. The authors treat thoroughly the magnetic circuit; Ohm's law; transformers and induction; motor generators and starters; storage batteries; alternating currents; capacity and inductance formulae. Vacuum tubes as detectors and amplifiers; oscillographs; radio compass; wavelength measurements and short wave receivers.

RADIO SERVICE MAN'S HANDBOOK WITH ADDENDA DATA SHEETS. Flexible covers, size 9x12", 200 pages, 200 illustrations. Price, prepaid **\$1.95**

This remarkable book contains several hundred illustrations with wiring diagrams and charts covering every conceivable subject, including radio sets, tubes, etc. The book is strictly up-to-date and contains the newest practical information which every radio man absolutely must have.

OFFICIAL RADIO SERVICE MANUAL, by Hugo Gernsback and Clyde Fitch. Flexible covers, size 9x12", over 1,000 illustrations, 352 pages. Price, prepaid **\$2.98**

Commercial wiring diagrams for all the regularly manufactured receiving sets are included in this manual and no radio service man or student who builds and repairs radio sets can be without this tremendously useful compilation of circuits and their descriptions. This book is worth \$100.00 to anyone who has a use for it. The Manual is indexed so that any commercial receiving circuit can be found instantly. One of the most valuable radio books ever published.

FUNDAMENTALS OF RADIO, by R. R. Ramsey, Professor of Physics, Indiana University. Cloth covers, size 9½x6", 372 pages, illustrated. Price, prepaid **\$3.50**

Dr. Ramsey gives us a very refreshing treatment of the fundamentals of radio, including battery and dynamo action; alternating currents; inductance; vacuum tube constants; aerials of different kinds and how they operate; radio frequency instruments and apparatus; audio amplification and receivers in general.

RADIO TROUBLE SHOOTING, by Ennor R. Haan, E.E. Flexible covers, size 6x9", 323 pages, 257 illustrations. Price **\$3.00**

This is a well illustrated and intensely practical handbook for all radio service men and operators, as well as set builders and testers. Some of the practical problems illustrated and discussed are: interference and noise problems—how to locate and remedy them; antenna circuit troubles and their effect on radio; batteries, chargers and eliminators.

DRAKE'S RADIO CYCLOPEDIA, by H. P. Manly. Cloth covers, size 6x9", 1035 pages, profusely illustrated. Price **\$6.00**

This massive cyclopedia covers radio apparatus—its operation and maintenance, the various subjects being alphabetically arranged. There are 1735 subjects in alphabetical order ranging from A-battery to zero-beat. This volume contains 1110 illustrations, diagrams, etc. There are 414 illustrations and articles on the building and designing of radio sets, alone; 110 articles with 383 illustrations on the methods of repair, service and adjustment of radio sets.

S. GERNSBACK'S RADIO ENCYCLOPEDIA, by S. Gernsback. Stiff leatherette covers, size 9x12", 168 pages, profusely illustrated. Price **\$1.65**

Radio apparatus, inventors and terms are all illustrated and described in this remarkable book which required the efforts of several engineers in its compilation. The subjects are alphabetically arranged and the illustrations are especially fine and clear.

TELEVISION TO-DAY AND TOMORROW, by S. A. Moseley and H. J. B. Chapple. Cloth covers, size 8x5½", 130 pages, profusely illustrated. Price, prepaid **\$2.50**

This up-to-the-minute work on television describes in detail the apparatus used by Baird. The student will learn all about scanning discs; the best type of motor; reverse defects and how to overcome them; isochronism and synchronism; various ways of synchronizing the receiving discs; photocells and neon tubes; radio receivers for television signals; noctovision.

SOUND PICTURES AND TROUBLE SHOOTER'S MANUAL, by Cameron and Rider. Cloth covers, size 8x5½", 1120 pages, profusely illustrated. Price **\$7.50**

This useful volume will appeal to all radio as well as "talkie" trouble-shooters. The first chapters deal with fundamentals of electrical circuits, including Ohm's law, A.C. and D.C. circuits, rectifiers, amplifiers, mixers and faders; various types of loud speakers and how to arrange them; photocells; electric motors; various types of talkie projectors; also commercial amplifiers with diagrams are given.

RIDING THE AIR WAVES, WITH ERIC PALMER, JR., by himself. Cloth covers, size 7½x5½", 328 pages. Price **\$2.00**

Short wave fans cannot miss reading this highly entertaining and informative book which tells the story of youthful Mr. Palmer and his remarkable achievements in amateur radio, "Around the World with 5 Watts" and many other interesting subjects appear between the covers of this book.

A POPULAR GUIDE TO RADIO by B. Francis Dashiell. Cloth covers, size 5½x8½", 286 pages, profusely illustrated. Price, prepaid **\$3.50**

The author starts off with an excellent section on electricity and magnetism; the use of radio aerials and grounds; the fundamental principles of radio; the electron tube and crystal rectifiers—how they work; the principle of radio amplification; radio inductance coils and condensers; fundamental radio receiving circuits; electrical reproduction of sound; the atmosphere and radio phenomena, etc.

RADIO VISION, by C. Francis Jenkins. Cloth covers, size 9½x6", 144 pages, profusely illustrated. Price, prepaid **\$1.25**

A beautifully printed and interesting illustrated history of transmission of images by radio; particularly covering the apparatus and successful demonstrations of the Jenkins system. Other apparatus illustrated and discussed are the Braun tube receiver; the R. C. A. Photo-radio apparatus; the A. T. & T. Company system; and the Belin machine.

RADIO MOVIES AND TELEVISION, by C. Francis Jenkins. Cloth covers, size 9½x6", 144 pages, profusely illustrated. Price, prepaid **\$2.50**

An absorbing history, handsomely illustrated, of the Jenkins system of transmitting and receiving movies "via radio." One of the chapters gives constructional details and drawings for building your own Radiovisor or machine for making the radio movies visible in your home. Diagrams of amplifiers are given, with some other very valuable information.

Howtoorder

We cannot make C.O.D. shipments. Our prices are net, as shown on this page. You will note that some of the books include postage. Those that do not will be shipped by express collect if you do not wish to include a sufficient amount of postage.

HUGO GERNSBACK

EDITOR

JUNE - JULY

1931



H. WINFIELD SECOR

MANAGING EDITOR

VOLUME II

NUMBER 1

Short-Wave Radio Prospecting

By HUGO GERNSBACK

DURING the past year, there has been built up an entirely new art, which promises to assume huge proportions during the years to come. It is of the highest importance to the entire short-wave fraternity, and is sure to revolutionize a number of industries.

It has been found that, with very simple portable short-wave apparatus, it is now possible to locate a great variety of materials underground. The mining and oil industries are particularly affected by this discovery; for it is quite certain that the new short-wave instrumentality will very quickly bring down materially the cost of locating deposits of metals, oils, etc.

Our planet is richly endowed with these various minerals, and it is only a matter of locating them economically. In the past, this was done by a hit-and-miss system and, though a good geologist could tell by the appearance of certain regions whether they were likely to hold ores or oils, yet there was nothing absolutely final about it. No doubt, many areas can produce natural wealth which could never be located by such means. It is now possible to explore the countryside systematically, since the guesswork has been almost entirely eliminated; and, as the new art goes on, there is no question that it will assume increasing importance.

The apparatus required is comparatively simple. We have a small, low-power modulated transmitter giving out a radiation of, say, between one and two meters in wavelength, and a simple reflector in the shape of a wire frame, by which the waves are concentrated into a directional beam. At another point, perhaps a quarter of a mile distant, an observer has a similar apparatus, which is used as the receiver. When the wave-beam from the transmitter is directed toward the earth, it is partly absorbed, and partly reflected upward; if any portion of the radiation is received by the observer, there is a sound heard in his headphones. If the soil is not uniform, but contains a body of ore, coal or other minerals of differing electrical conductivity, the angle of reflection of the beam is changed, and the strength of the signal is correspondingly altered.

By listening to the sounds in different positions, and noting their various intensities, it becomes possible to plot the subterranean strata and to judge of their nature. For instance, an operator on the surface of a frozen lake can map out the contour of the shore, though it cannot be seen. By systematic observation, it is even possible, for one who understands thoroughly the geology of the region which he is prospecting, to know whether ore, coal or oil is to be found below, and to judge the position, dimensions, and importance of the underground deposit. Thus, for instance, it was discovered that untouched deposits lay a few feet beyond the last workings of an abandoned gold mine; as told in an interesting article which is published in the current (June) issue of RADIO-CRAFT Magazine.

It must be understood that, before undertaking work, or even experiments, of this kind, one must have both a radio operator's license from the Department of Commerce and a short-wave experimenter's license to work in the non-exclusive experimental range below five meters. The reason is that the law forbids any transmitting work, no matter how short the range which it is intended to cover, without a license.

Those who are sufficiently versed in geology and mineralogy will find a technical discussion of the problems of locating mineral bodies in the *Proceedings of the American Institute of Mining and Metallurgical Engineers*, (New York City); particularly, in their Technical Publications Nos. 98, 130, 131, 313 and 415; and in "Adaption of Elastic-Wave Exploration to Unconsolidated Structures," by Frank Rieber (Boston meeting, August, 1928).

The radio features of the work are comparatively simple, for those who have experience with ultra-short-wave receivers; since neither the transmitter nor the receiver is complicated. What is required is practice in their application.

The art of *radio prospecting* is, of course, as yet in its earliest infancy, but I predict great things for it. No one knows, at the present writing, the full extent of its possibilities; but it is equally certain that those who take up its development, now, have before them a great future.

SHORT WAVE CRAFT IS PUBLISHED ON THE 15th OF EVERY OTHER MONTH

THE NEXT ISSUE COMES OUT JULY 15th

WHEN HELLMUT

By WILLIAM BURKE MILLER

Director of Special Broadcast Events,
National Broadcasting Co.
(Specially Prepared for SHORT WAVE
CRAFT.)

Mr. Miller, whose likeness we see at the right, here tells us about some of the extremely interesting broadcasting events which have been sent over the N.B.C. network. Mr. Hellmut, Germany's "Floyd Gibbons," recently talked to Germany from the top of the Statue of Liberty, and a number of other unusual locations. Our cover shows an interesting possible application of special broadcasting, with a portable short-wave transmitter strapped to the announcer's chest.



At left we see how the N. B. C. special broadcasting outfit looks when "going into action." This mobile short-wave transmitter and receiver was located at the bottom of the Statue of Liberty, when Mr. Hellmut talked to Germany. Photo at right below shows (left to right) Hellmut, Wallington, and Paul Schwarz, German Consul, on top of the base of the statue. Note telescope used by Mr. Hellmut.

THE day of broadcasting special events from a central stationary microphone point has been swept aside by NBC engineers and, now, almost any broadcast is possible.

No longer do a limited number of radio listeners hear an announcer "bringing So-and-So to the microphone to say a few words." The microphone goes to So-and-So; whether that person happens to be on the dome of the United States Capitol at Washington, in a sky-skimming airplane, or in a submarine nosing about in "the waters under the earth".

And the world is the limit!

The engineers of the National Broadcasting Company, while carefully developing practical transmitting apparatus, have utilized the characteristics of short-wave transmission to permit the sending of programs from points not reached by wire lines; and they have designed portable short-wave transmitting apparatus to give their announcers, and others of verbal prominence, a wide latitude for "cruising".

Chief among NBC's engineers to devote specific development attention to portable short-wave transmitting equipment is R. M. Morris. He drew up plans, and supervised their execution, that enabled us to bring all manner of "impossible" programs to the ears of millions of radio listeners in the United States and scores of foreign countries.

Germany's "Floyd Gibbons", Hellmut H. Hellmut, describing New York's skyline from the top of the Statue of Liberty. Photo shows Hellmut (right) and James Wallington, N. B. C. announcer.

The "Roving" Radio Reporter

The latest addition to our far-reaching program of crack broadcasts, is the group of unique radio offerings from widely varied points in the eastern United States by Hellmut H. Hellmut, Germany's "roving radio reporter". Hellmut, a dynamic personality, sought out such places as the Capitol dome and the White House in Washington, D. C.; the Statue of Liberty in New York harbor and a New York skyscraper; and the "grain pit" in Chicago.

Armed with two portable microphones and a kit-sized short-wave transmitter, the young German described his experiences to the United States and Germany; the broadcasts being heard in this country through NBC networks and abroad by



GOES GUNNING for ACTION

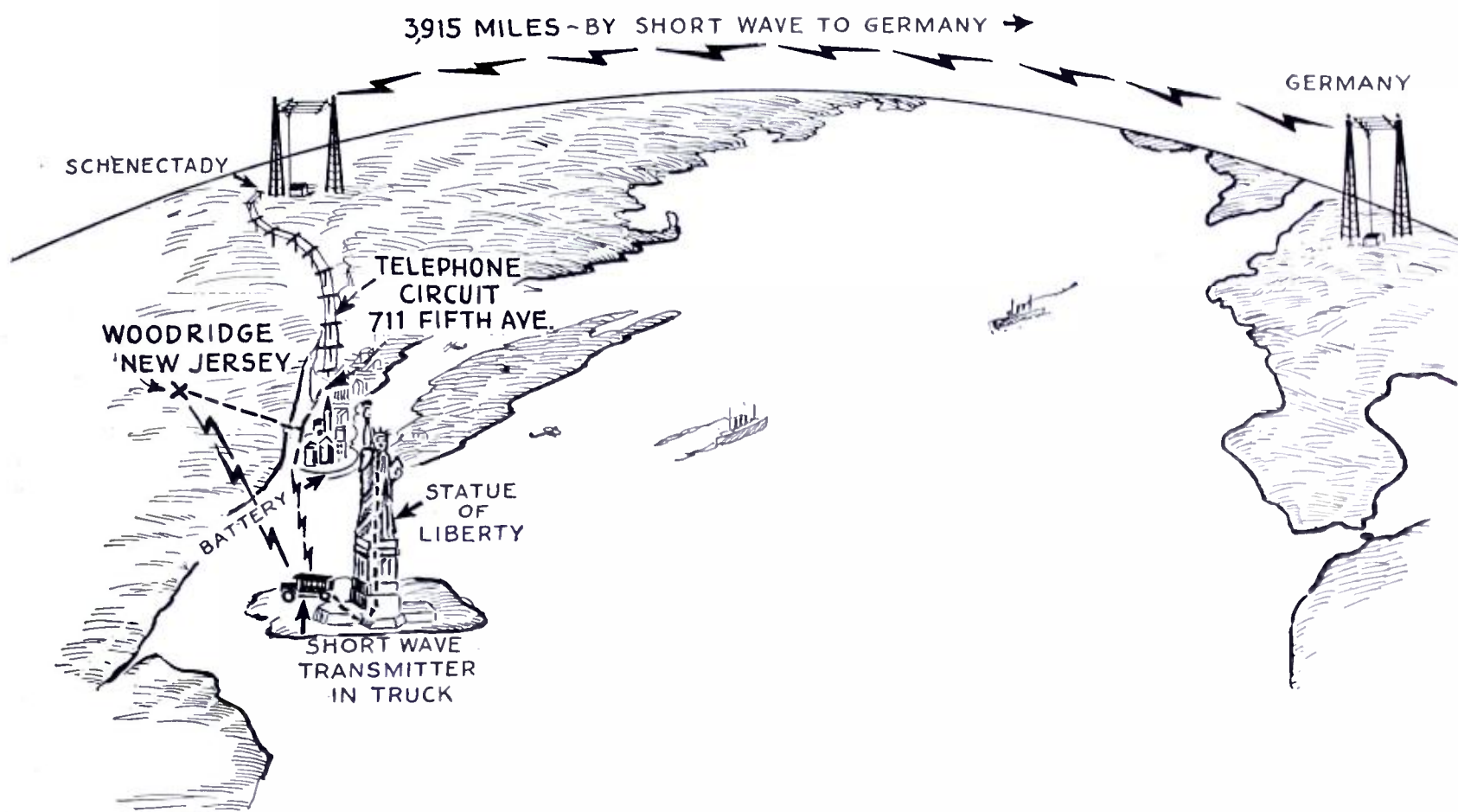

Comprehensive view of the famous "short-wave" broadcast to Germany carried out in conjunction with N. B. C. by Hellmut H. Hellmut, Germany's "Floyd Gibbons," who described New York's skyline to his German audience over the combined wire and radio circuits shown in the picture.

transmission on short-wave lengths to German stations.

This is merely one illustration.

NBC likewise has been far afield in "going places and doing things"; and radio listeners have been thrilled to their soul on hearing word pictures of:

—The three-point coverage of the United States Navy fleet review off Hampton Roads, in which one 50-watt short-wave transmitter was operated ashore; another aboard the U. S. S. *Salt Lake City*; and a 7½-watt unit aboard the dirigible *Los Angeles*. Three-way conversation, concerning movements of the fleet as it passed in review before the President, was maintained.

—The America's Cup races off Newport, R. I., in which the only ship-to-ship interview of radio was staged by an NBC announcer aboard one craft and a yachting expert on another.

—"Over and under New York," with one of our announcers high up in an airplane, another deep in an excavation beneath the East River, and both telling of their sensations; the words of both being broadcast over our far-flung NBC networks.

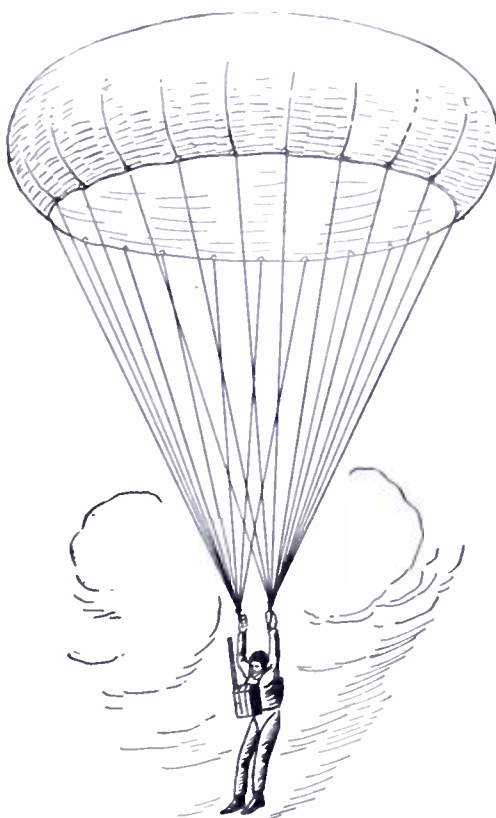

One of the most novel of all special broadcast events was that carried out some time ago by a man descending with a parachute, the short wave transmitter being strapped on to his chest.

"Buddy" Bushmeyer's Parachute S-W Broadcast

—"And I'm leaping out of the plane now," the cry of the late "Buddy" Bushmeyer, describing his reactions when he stepped into thin air with one of NBC's portable short-wave transmitting sets and a trusty parachute. "Buddy" became tangled up in his antenna wires on the first jump, but a second attempt was successful.

—Floyd Gibbons, as he told the world of the arrival of the *Graf Zeppelin* at Lakehurst. The war correspondent strolled about the giant airport with an NBC portable short-wave transmitter, followed by two men who bore a "walking antenna" suspended between two tall poles.

—Bringing the yelps and howls of jungle animals in the Bronx Zoo, New York, to the ether enthusiasts; which marked one of the early occasions in which our mobile transmitter, a complete broadcasting unit encased in a closed automobile truck, was used.

—Down close to "Davey Jones' locker"; with an NBC announcer, and assistants, talking from the U. S. submarine *O-8*, as the steel fish split the

(Continued on page 67)

7 Inch Waves Span 21 Miles

The consistent transmission and reception of ultra-short waves only seven inches long, for communication over a distance of approximately 21 miles, between Dover, England and Calais, France, comes as a great surprise perhaps to many short-wave students. Not only was perfect radiophone operation carried on, but also the radio transmission and reception of pictures. The transmitting and receiving stations were practically in sight of one another and the waves were focused by accurately constructed parabolic reflectors. The tests were remarkably free from fading and interference.

inches) is now available for commercial radio transmission.

Tests Showed Absence of "Fading"

In the demonstration a link had been established between a station on the cliffs of St. Margaret's Bay, near Dover, and a similar station across the English Channel at Blanc Nez, near Calais. The two-way radio telephone circuit, using a wavelength of 18 centimeters (7 inches) was noteworthy for the quality of speech received. Not only was it well up to the standard of a high-quality telephone circuit, but it showed no signs of being affected by fading—a disability from which waves of this frequency are apparently immune.

When compared with radiations of the more usual wavelengths, "micro rays" present many striking features. For example, their extremely short wavelength permits the use of electro-optical devices more usually associated with light, such as reflectors or refractors, in addition to diminutive antenna systems. A further similarity between these radiations and light is that fog, rain, and such like climatic effects, as well as day and night, do not materially interfere with the propagation of the waves.

The two stations at Dover and Calais

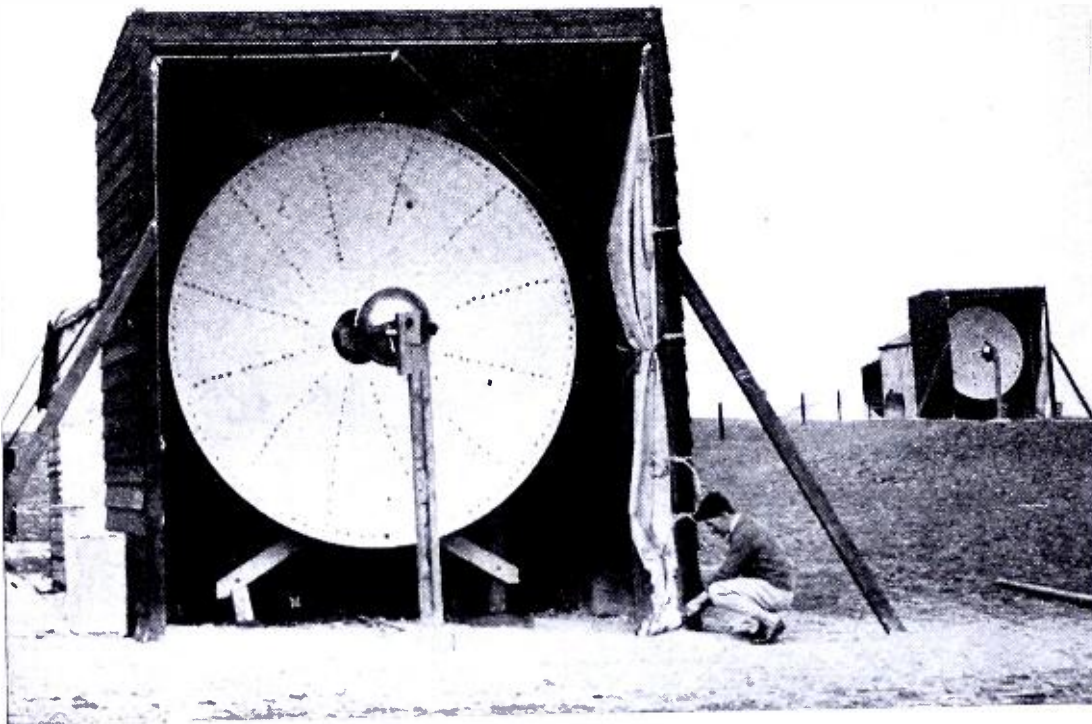

Seven-inch, ultra-short-wave radio transmitting (left) and receiving (right) stations on the cliffs of Dover, England, from which speech as well as picture signals were exchanged back and forth across the English channel, with a similar station near Calais, France. Part of the transmitted wave passes through a hole in the reflector on to a wavemeter.

The authentic information here presented on the recent 7-inch wave tests was obtained from Mr. H. T. Kohlhaas, of the engineering staff of International Telephone & Telegraph Corp., and Editor of "Electrical Communication".

ON the cliffs of Dover, England, on March 31st, the International Telephone and Telegraph Laboratories, of Hendon, England, in cooperation with the laboratories of Le Matériel Téléphonique, Paris, France, gave a successful international demonstration of a new ultra short wave radio telephone and telegraph equipment and circuit between Dover and Calais, France. This equipment was largely developed by French engineers in the Paris laboratories. The demonstration at Dover was conducted by engineers of the International Telephone and Telegraph Laboratories and at Calais by engineers of Le Matériel Téléphonique.

Waves As Short As 4 Inches Used

In this demonstration, oscillations of wavelengths as low as 10 centimeters (four inches) designated as "micro

rays," were used for the first time to provide a high-quality two-way radio telephone circuit. From the distances covered and results obtained, it was quite clear that the equipment employed can readily be adapted to commercial use. Though a certain number of experimenters have already succeeded in generating and utilizing oscillations of such wavelengths, nothing beyond what may be described as *laboratory investigations* has up to now resulted. The enormous advance in technique shown by the present demonstration definitely indicates that the range of wavelengths as low as 10 centimeters (four

A close-up view of seven-inch, ultra-short-wave receiver, with its tiny aerial located at the focal point of the reflector. Two reflectors are used as the picture shows.

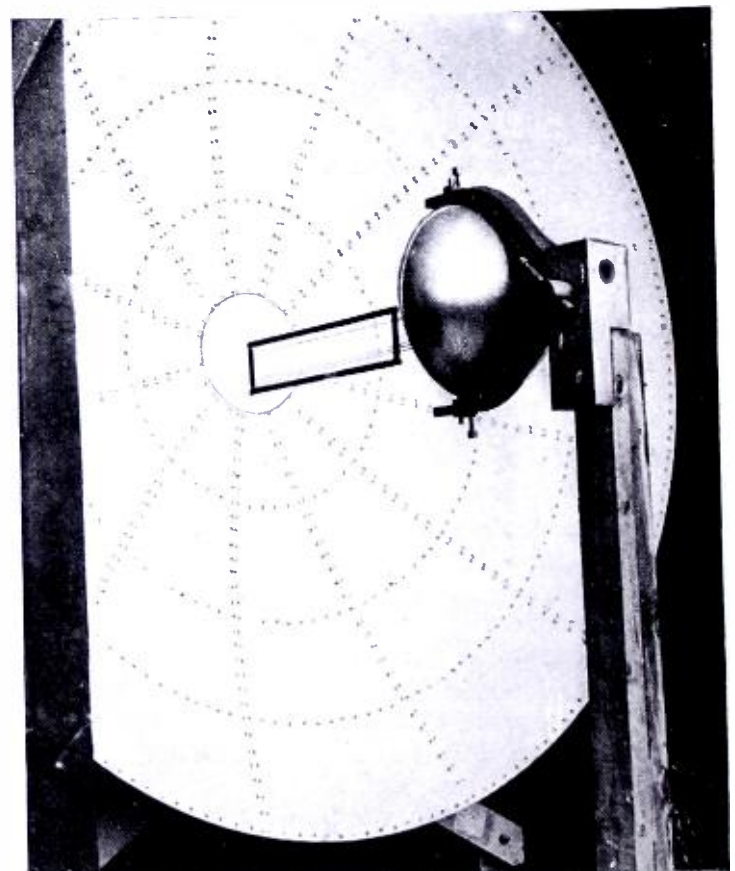

Photos courtesy of International Tel. & Tel. Co.

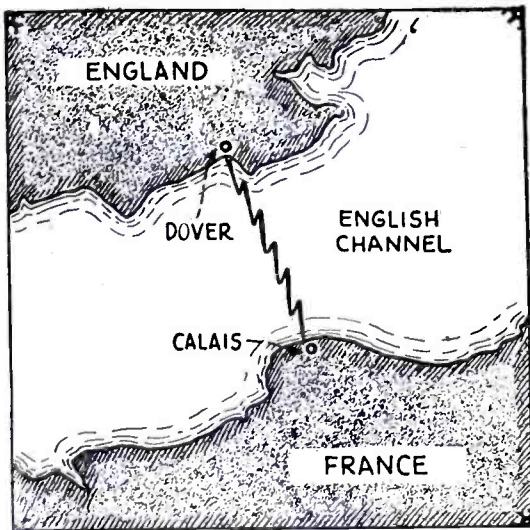

This map shows the location of the epoch-making, ultra-short-wave experiments across the English channel, between Dover and Calais.

were in all essentials identical. Each comprised a transmitter and receiver, with terminal equipment of normal design for connecting them together, to give facilities for two-way communication.

The Transmitter

One of the diagrams shows the essential features of the transmitter, and the photographs illustrate the appearance of the transmitter and receiver at Dover.

The outgoing signals are applied to a "micro-radion" tube in which the high-frequency oscillations are generated. A short transmission line connects the "micro-radion" tube to the radiating system or doublet which is about two centimeters long (0.8 inch!) in contrast to the enormous system usually employed. The amplitude of this high-frequency current along the doublet at any instant is substantially the same. The doublet is situated at the focus of a paraboloidal reflector some three meters (10 feet) in diameter. After concentration of the rays by the paraboloidal reflector into a fine pencil of rays, somewhat similar to light rays sent out by a searchlight, they are projected into space.

In the reflector the relation between the focal length and the diameter is so proportioned as to ensure maximum efficiency for the diameter used. In order further to increase the efficiency of the system by the prevention of radiation, other than in the required direction, a hemispherical reflector, having the doublet at its centre, is located at the opposite side of the doublet from the paraboloidal reflector. This serves to collect all the radiation propagated in a forward direction and to reflect it back again towards the source. The radius of the hemispherical reflector is so chosen that, when the reflected radiations reach the focus again, they are in phase with those being radiated at that instant. The appro-

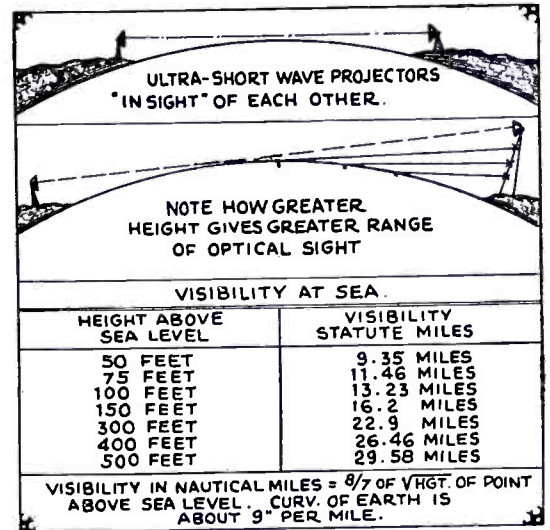

The diagrams above show roughly how the ultra-short-wave transmitters and receivers have to be elevated, so as to "see" each other.

ropriate length of the radius depends upon the wavelength, the relation being that it should be substantially a multiple of half wavelengths. The multiple is so chosen that the radius shall be large enough to ensure that the reflector has satisfactory electro-optical properties; but not so large as to intercept unduly the radiations reflected forward from the paraboloidal reflector.

(Continued on page 65)

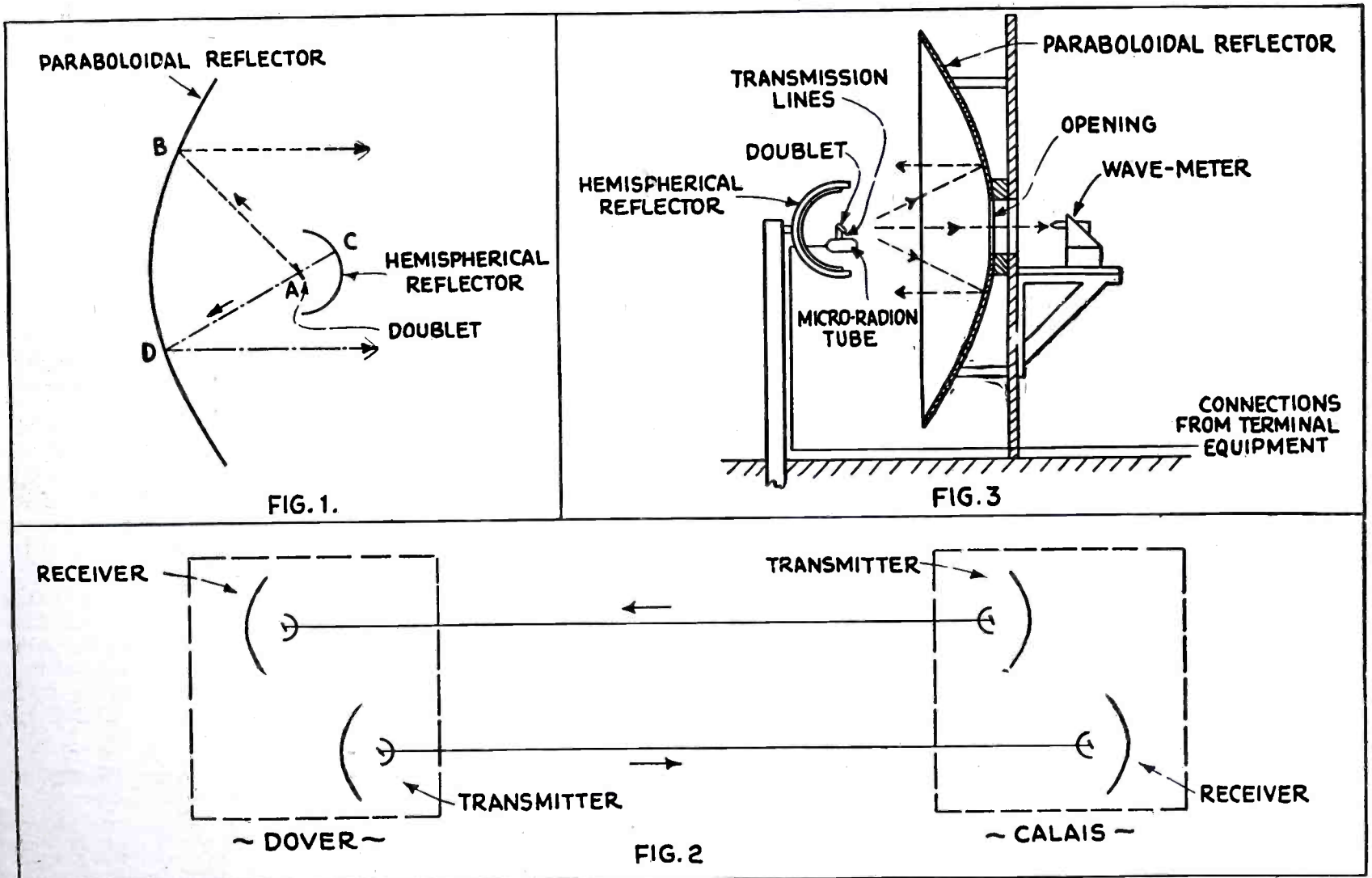

The diagrams above show arrangement of the antenna doublet in the focus of the two reflectors (Fig. 1); while at Fig. 3 we see a side view of the ultra-short-wave transmitter, with part of the energy passing through the opening in the large reflector on to the wavemeter. Fig. 2 shows schematic arrangement of the two transmitters and receivers at Dover and Calais.

SHORT WAVE AMATEURS

The unquestioned value of amateur radio engineers, is here thrillingly described.

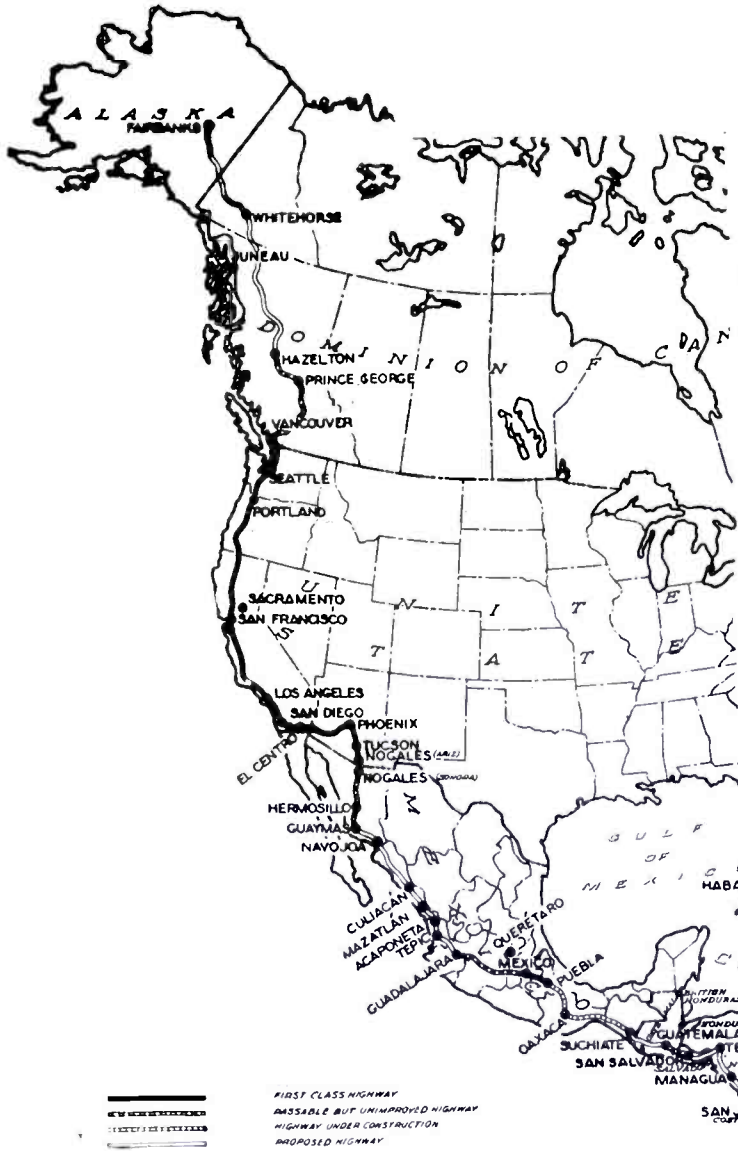

Charles Lundblad, W6FE, whose 75-watt transmitter, together with his Zeppelin antenna and excellent S-W receiver, relayed many messages from the trail-blazers with admirable speed and accuracy.

HISTORY is being made these days, down to the south of us, in that vast sister land famous for its sombreros, siestas, bananas, and gorgeous scenery. A party of six stalwart American scouts, traveling in three motor cars and carrying with them complete short-wave radio transmitting and receiving apparatus, are breaking trail for the most stupendous highway project of the western hemisphere.

The International Pacific Highway expedition, sponsored by the Automobile Club of Southern California, is blazing through the jungles of Central America a trail that will ultimately become a broad highway providing a major link for commerce and travel between the two American continents. The proposed road will traverse the west coast of the Americas from Alaska to Argentina, extending the present Pacific Highway (which is already the longest paved road in the world, stretching 1,560 miles from the Mexican to the Canadian border) northward through British Columbia and Alaska to Fairbanks, southward through Mexico, and the Central American republics to Buenos Aires. As the expedition's chief communicating link with the rest of the world, radio is playing a most important part in this ambitious project;

which will enable the motorist to journey more than 15,000 miles from the Arctic almost to the Antarctic, passing through nearly a score of countries, and needing knowledge of but two languages, English and Spanish!

The first step toward the realization of the proposed highway was taken last March, when five cars drove out of the Automobile Club's headquarters at Los Angeles in a pouring rain, sans the official motorcycle police escort and aerial convoy that had been planned, but given a hearty send-off by public

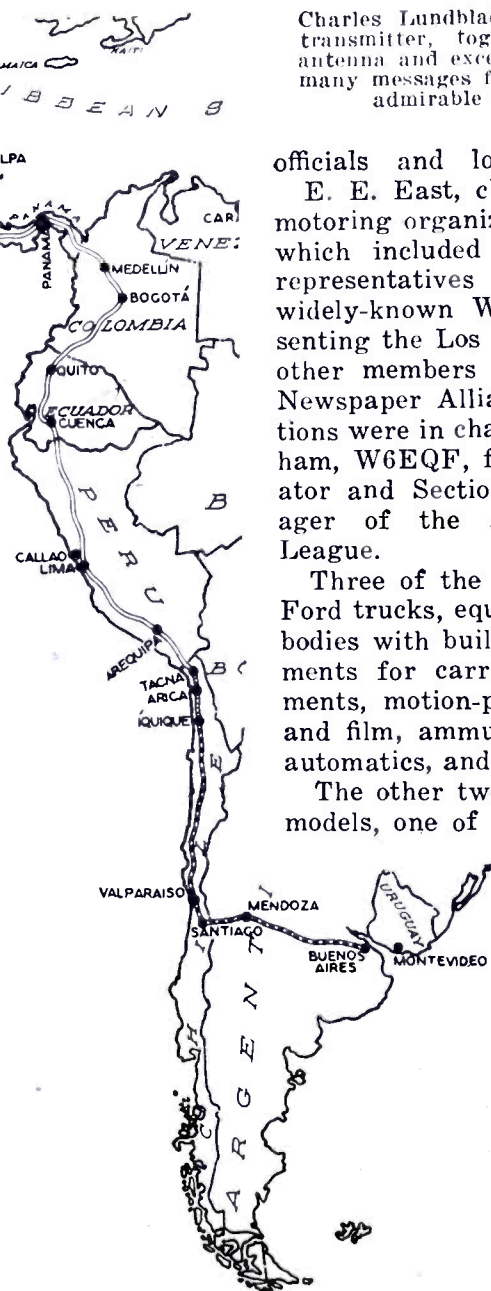

officials and local señoritas as well. E. E. East, chief engineer of the big motoring organization, headed the party, which included also seven other Club representatives beside Harry Carr, widely-known Western columnist representing the Los Angeles Times, and fifty other members of the North American Newspaper Alliance. Radio communications were in charge of Bertram E. Sandham, W6EQF, former U. S. Navy operator and Section Communications Manager of the American Radio Relay League.

Three of the five cars were converted Ford trucks, equipped with heavy special bodies with built-in waterproof compartments for carrying engineering instruments, motion-picture and still cameras and film, ammunition for the rifles and automatics, and so on.

The other two cars were open touring models, one of which was designated as the radio car; the other carrying special mileage recording equipment, altimeter,

Map shows the projected route of the International Pacific Highway as prepared by the Automobile Club of Southern California and running along the backbone of the two continents.

Link Trail-Blazers with Base

operators, as brilliantly exemplified by their fine cooperation with trail-blazing

By STERLING GLEASON

gradometer, two compasses, and other instruments used by the engineers in making a complete record of topography and road information. As the party traveled, a chartman sat at these instruments, logging every detail of the passage, including all cross-roads, elevations, bridges, churches, or other important structures, gasoline stations and garages, mileages, grades, elevations, and all other data that would later be of use to the map-maker, road-builder, or tourist.

Details of the Radio Equipment

The decision to carry radio equipment came but ten days before the scheduled date of departure, and in that short space of time, Sandham had to build the transmitter and receiver, arrange for mounting them safely in the car, make a portable antenna mast, provide suitable "A" and "B" battery sources and, in addition, arrange reliable communication schedules with local radio amateurs. The transmitter circuit chosen is a tuned-plate, tuned-grid layout with two type '10's in parallel; and the receiver is a conventional regenerator, with two stages of audio amplification. An extra storage battery was hung beneath the floor-

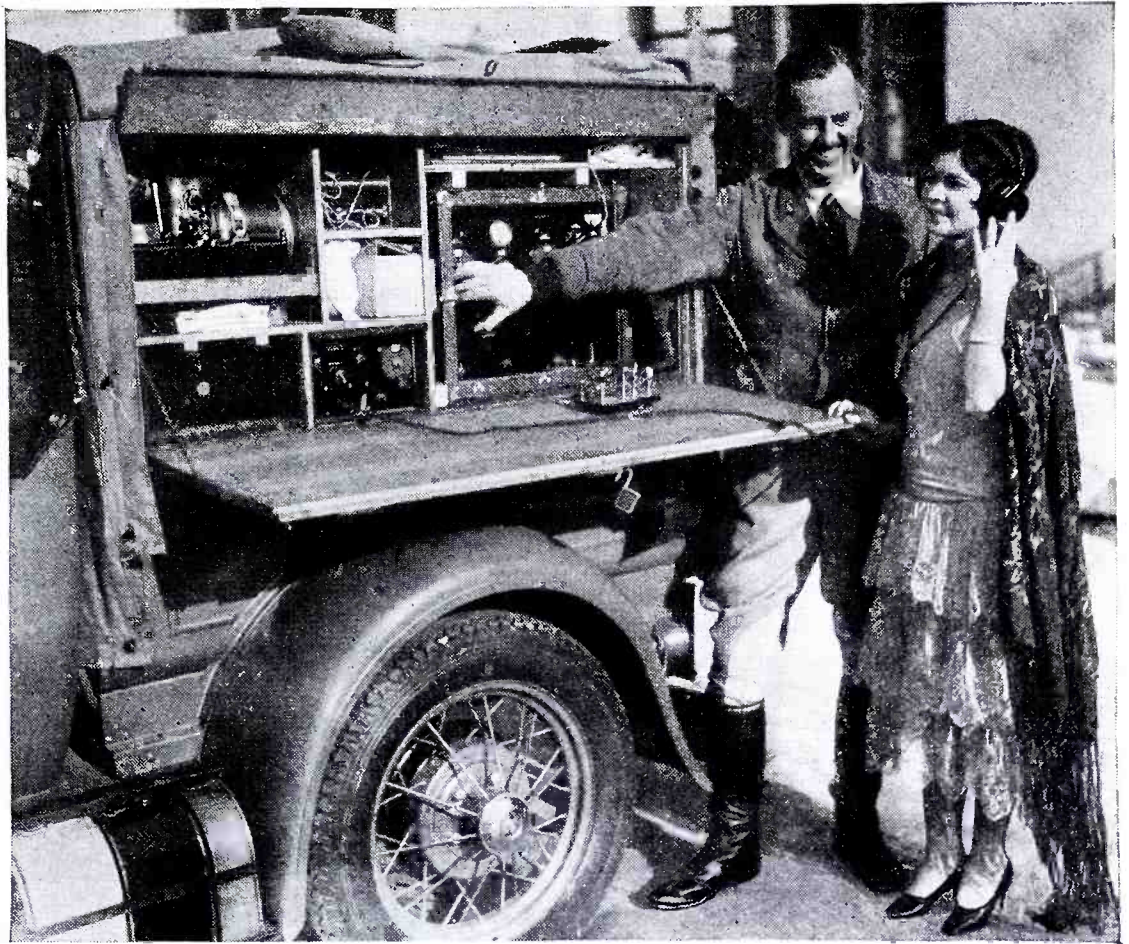

The radio operator of the trail-blazing "outfit", Mr. B. E. Sandham, demonstrating the short-wave radio receiver to a fair seniorita.

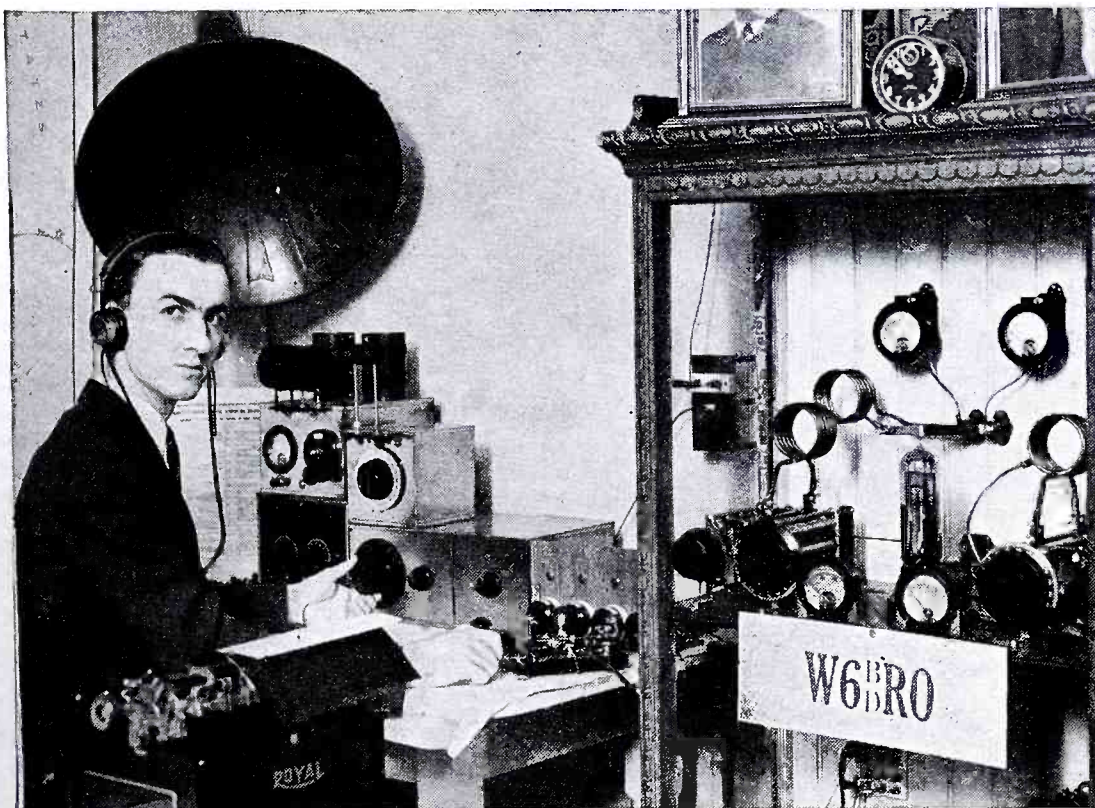

One of the chief links between the trail-blazers and the Los Angeles office of the Automobile Club of Southern California was W6BRO, Charles A. Hill's station. The transmitter in the glass cabinet at the right, is a tuned-plate, tuned-grid outfit, with mercury vapor rectifier. The receiver has its stages individually shielded with copper cans.

boards of the car, with switches to place both batteries in series for the transmitter filaments, or in parallel for charge.

Between the front and rear seats was built a waterproof box to hold fourteen 45-volt "B" batteries, and a long 7-wire cable provides flexible connections to the sets; which are mounted in a single cabinet, provided with handles for carrying, which may be set upon a portable table. Two antennas were wound upon a single reel—one for the 7,000-kc. band, and one for the 14,000-kc. range, the latter frequencies being used chiefly for daylight work.

Heavy rains pursued the caravan throughout its entire trip from Los Angeles to Nogales, delaying the party for hours and completely dislocating an impressive schedule of official receptions all along the line. International courtesy waived the ordinary customs inspections; with the result that the party crossed the boundary line with few formalities.

Mexico to Los Angeles "via Honolulu"!

As the expedition had not had time to obtain a U. S. station license and call letter, its transmitter was silent until the caravan had entered Mexico. Once

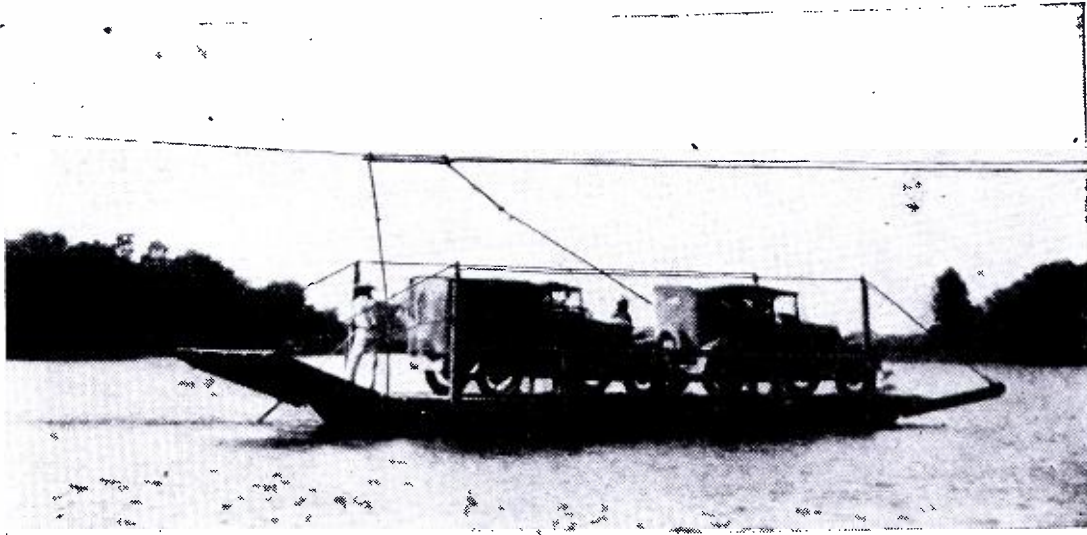

The trail-blazing caravan had many thrilling experiences during their exploration of the proposed International Pacific Highway route; crossing by ferry over the Sinaloa River.

across the line in the State of Sonora, however, Sandham came on the air for the first time, using the call IPH—symbolic of the initials of the expedition—and plunged into his chief work, that of relaying official messages.

Since fifty-one American newspapers were depending upon genial Harry Carr for news representation, his press copy had to go through; but one of the first discoveries Sandham made was that with the coming of darkness, all Pacific coast signals faded completely. Fishing anxiously for a western station through whom to relay Carr's copy, he suddenly picked up the signals of a Honolulu amateur, whom he succeeded in contacting immediately. The entire file of messages thus traveled halfway across the Pacific, enroute to Los Angeles, only 600 miles distant!

Radio Operator Swamped With Messages

As soon as local Mexican officials discovered the expedition's radio set, they began immediately to file message after message in Spanish for immediate dispatch. An apparently endless night's work for Sandham was finally halted by the timely arrival of rain. Inclement weather delayed further progress of the expedition for several days; but after a thorough drying-out of equipment, the scouts pushed southward into the heart of Mexico.

From this point onward, the journey became a hectic round of toilsome drives by day, over primitive highways innocent of surfacing or improvement, and evenings of continual receptions, barbecues, fetes, fiestas, and flowery oratory. The enthusiasm with which the explorers were greeted everywhere filled every spare moment with entertainment which, while gratifying and flattering, nevertheless cut heavily into much-needed repose. At times they were able to get only one hour's sleep in two days. Sandham especially suffered; for while other members of the party were turning in for a few winks, the poor radio operator, perforce, had to rig up his transmitter and go "on the air" to meet schedules.

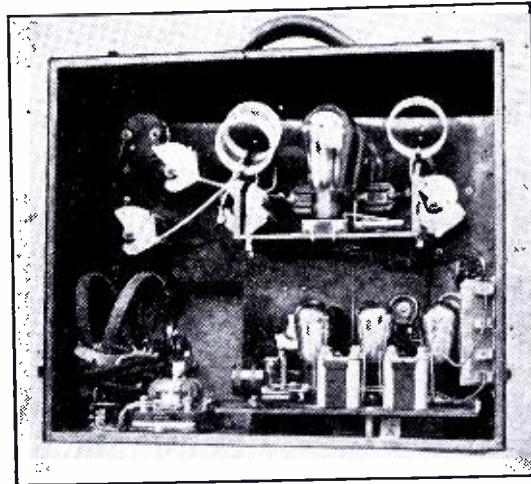

Close-up view of portable short-wave receiver.

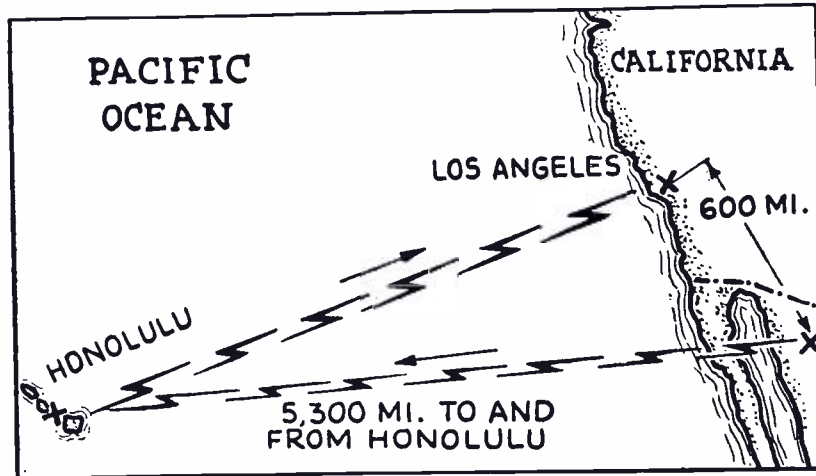

Map above—One of the most remarkable short-wave transmission stunts imaginable—a message transmitted from the caravan's portable set, having been picked up by a Honolulu amateur and relayed back to Los Angeles, the message travelling a distance of about 5,300 miles, in order to bridge a gap of 600 miles.

Where to Hang That Aerial ?!x?

When the expedition arrived in any town to spend the night, Sandham's first job was to select a place to set up the antenna. Generally this was a matter of touring the city, with an eye out for suitable flagpoles or tall buildings sufficiently removed from leaky power transformers to make reception possible. With the primitive electrical equipment usually encountered—trees often serving as poles and barbed wire as conductors—this type of interference made reception a difficult task. In Mexico City, after a long search for a suitable location, Sandham finally tied his antenna lead to an oil derrick on the outskirts of town, and set up his equipment not fifty feet from a puffing boiler and panting steam engine. Even this unholy racket proved less distracting than the electrical interference downtown.

Natives Mystified by S.W. Radio

Setting up the radio apparatus was always a source of much mystified amusement to the natives, many of whom in the more remote districts, such as the *barrancas*, had never seen even an automobile. When Sandham had picked the location for his antenna, there were always many willing hands to assist. Lack of a common language often led to embarrassing misunderstandings, as when one of Sandham's self-appointed assistants, misinterpreting gestures and shouted commands, threw coil and all from the top of a high building, instead of lowering one end only for an antenna

(Continued on page 72)

Photo below shows close-up of Mr. B. E. Sandham, radio operator with the International Path-finding caravan of the Automobile Club of Southern California. Many thrilling experiences were met with by the caravan, not the least of which were some quite remarkable "short-wave" stunts.



7 Meter Radio Used on English Tanks

SHORT WAVE radio sets operating on such unusual wavelengths as 7 and 8 meters, have successfully been tried out by the British on some of their army tanks, as the accompanying photos show. The photo directly below shows a radio operator at work on one of the Marconi short wave sets installed in a Vickers-Armstrong tank, while the right-hand photo shows the tank in action with its 12 foot telescopic radio mast elevated. This mast represents a clever piece of ingenuity, as it is

very flexible and will not buckle. The mast is also practically invisible, so reports state, the mast shown having been retouched on the photo by a staff artist.

A feeder cable connects the short wave transmitter to the aerial system, which is connected to the body of the tank (ground) through a balancing coil, so as to permit the maximum amount of energy to be transferred to the aerial for the particular wavelength used.

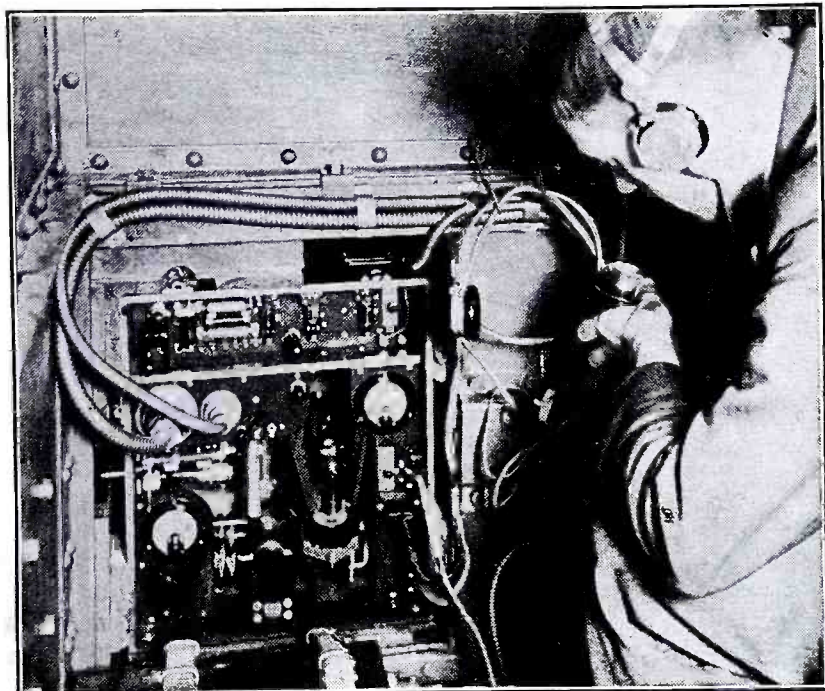

Operator talking into "mike" of S-W "tank" transmitter.

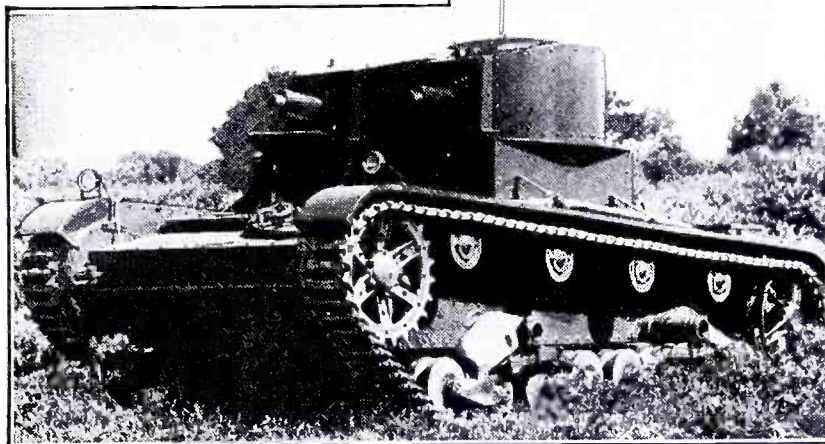
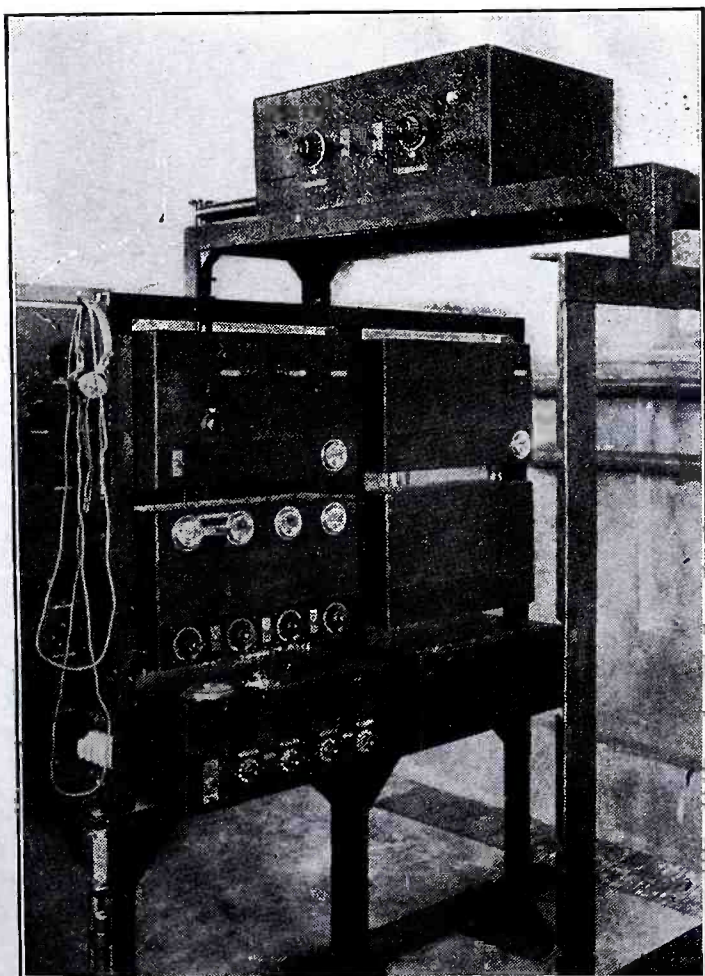
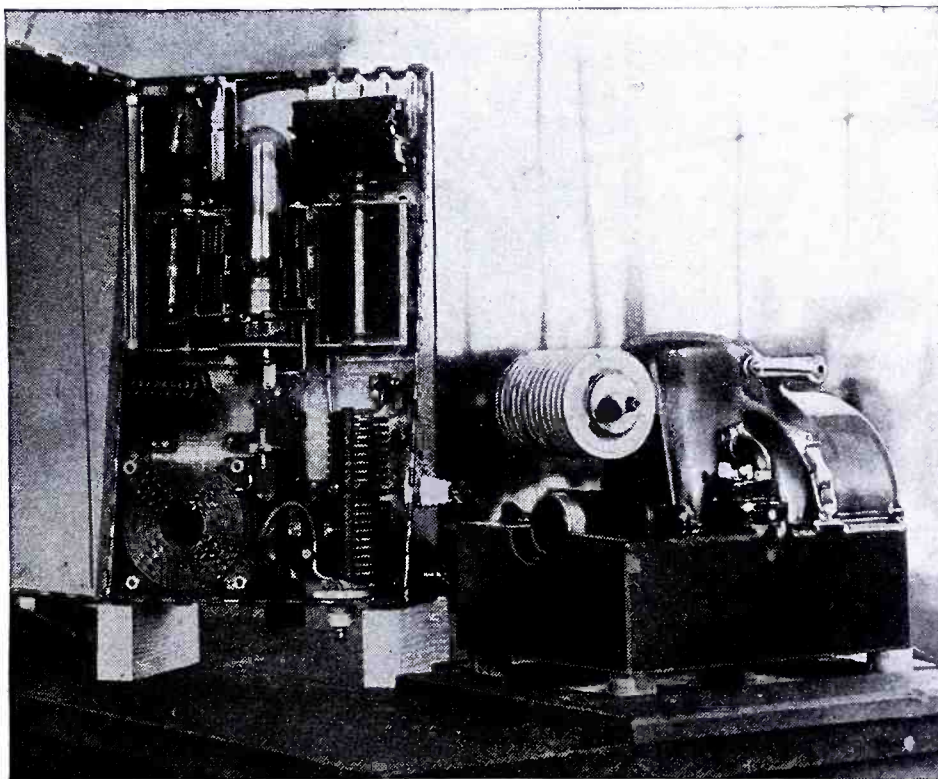

Photo above shows British army tank of the Vickers-Armstrong type with its radio mast elevated. When a large number of these tanks go into battle and the field is obscured by smoke, it is very desirable to have a reliable means of communication established between the tanks and headquarters. The short wave transmitter and receiver used in these tanks operate on a wavelength of from 7 to 8 meters. Photo at the left shows operator inside the tank, together with short wave transmitter and receiver. The operator is holding a microphone, into which he is talking; the apparatus can be used for either radio telegraph or phone transmission.

Transatlantic Short Wave Receiver



Short Wave Sets for Life-Boats



Picture above shows one of the latest short wave transmitters, together with self-contained gasoline engine and dynamo for installation on lifeboats of the new eight million dollar turbo-electric Dollar Line ships. Every lifeboat on these new ships will be equipped with one of these radio outfits, capable of operating over a period of 300 hours. The photo at left shows short wave superheterodyne transatlantic receiver used in a French commercial

Two or More Programs on a Single ULTRA-SHORT WAVE

By BARON MANFRED VON ARDENNE

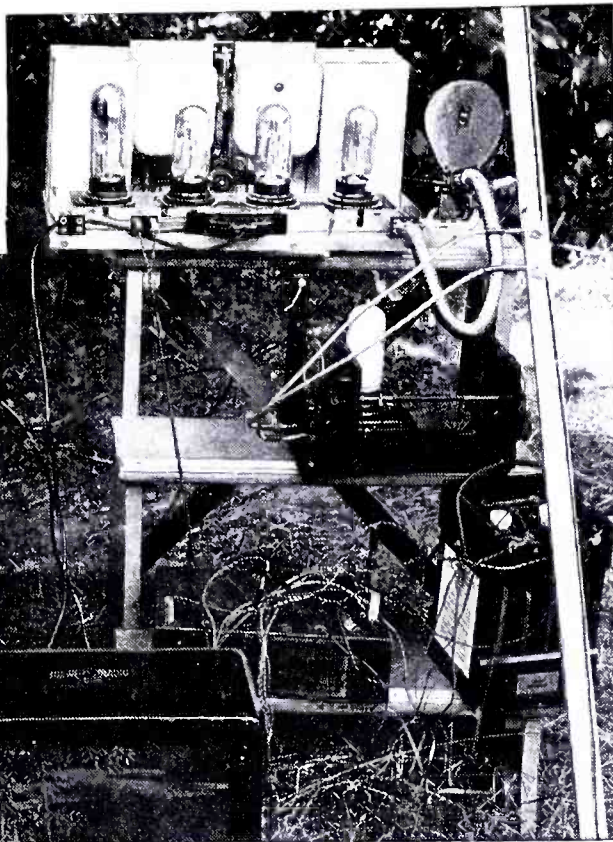

The dream of every radio engineer has been the transmission and reception of more than one program over a single radio wave, particularly useful in transmitting the voice simultaneously with the image. The author in this article explains how this can be accomplished by multiple modulation of a single short wave.

tion, in comparison with direct-wave broadcasting, is as follows: the direct waves are everywhere lost to the listener in the country; while the re-radiated waves, through the various amplifications of main and relay transmitters, interfere only in vaguely-bounded zones, which may extend to a radius of some 125 miles, under the most unfavorable circumstances (*i. e.*, for cities having the area of Berlin, for example).

In this state of affairs, there are doubtless countries in the world into whose radio organization this field-amplification will fit well; that is, where the advantages far outweigh the disadvantages. The re-radiation of the waves,

THE ideal, in so far as good reception conditions throughout a large city are concerned, consists in attaining this aim without involving any changes in radio apparatus.

In this sense the author has first considered the principle of general amplification of all signals in the field; against which a number of valid objections have been made. The most important concerned the question of the zone of fading, which is created in the re-radiation of the same frequencies throughout a large city. Consideration of the interference phenomena is, among others, one of the most important reasons why a change was made from the feasible idea of a general, aperiodic field amplification to the amplification of only a certain few waves.

If the few stations to be relayed are satisfactorily selected, then the harmfulness of the fading zone is reducible to a minimum. If only those stations are relayed whose offerings can be heard on other waves, then even the listener out in the country, who is in the critical zone, will always be in a position to receive the program wanted. Even if this viewpoint is not justified, the radio

Baron Manfred Von Ardenne, the author of this article.

Fig. 1—Apparatus shown above is the author's experimental arrangement employed for the simultaneous reception of two different programs over a single ultra-short wave.

Fig. 2—At right shows rear view of a supplementary set for receiving a radio signal transmitted by double modulation of a single wave.

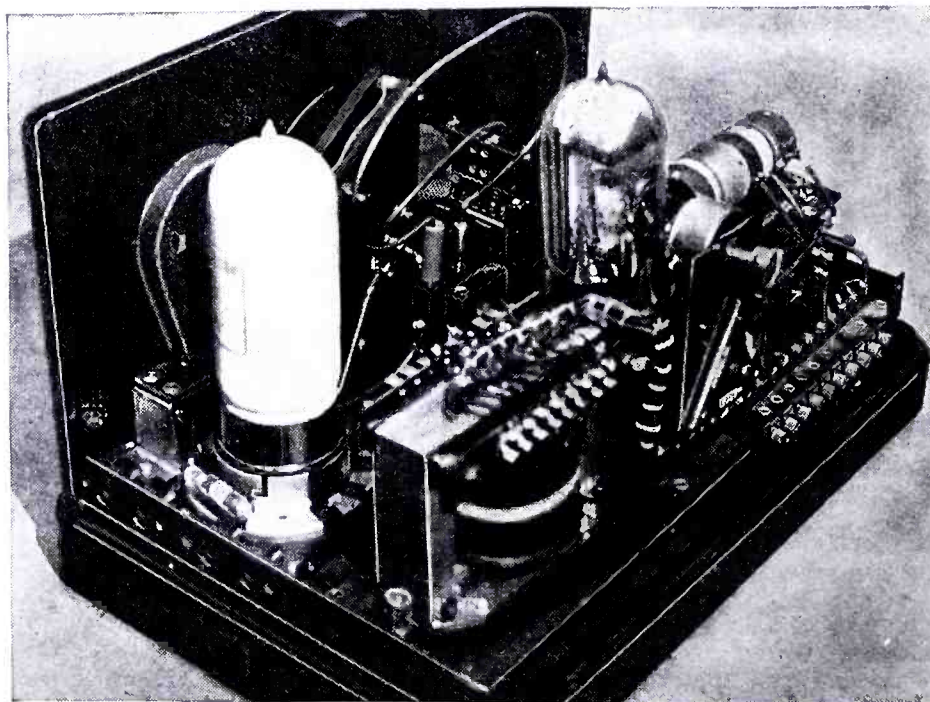

listener living in this zone will hardly notice the fairly considerable fading which happens on four or five waves, among from forty to sixty.

A basic advantage of field amplifica-

against which the objections raised are almost exclusively directed, is not, after all, fundamentally necessary. From the ideal mentioned at the beginning, it is possible to revert to a previous stage of

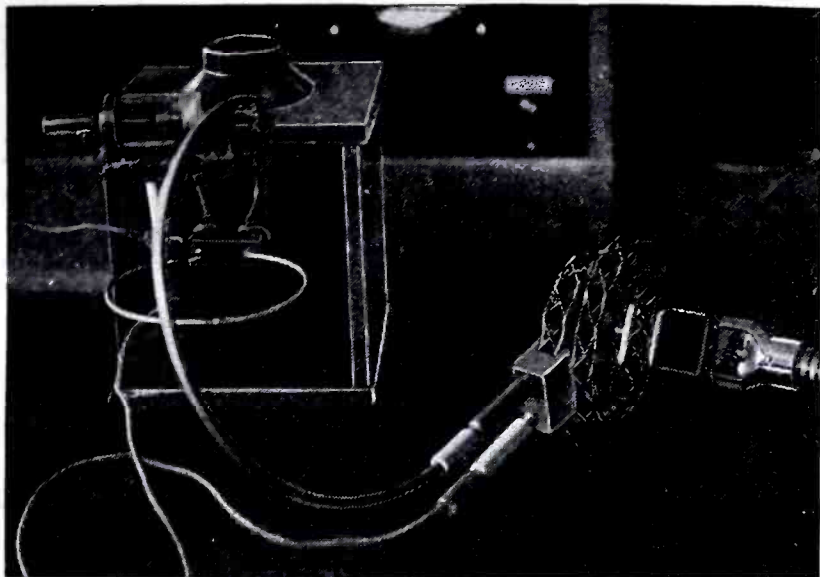

Fig. 3—The picture at the left shows a simple receiving tuner comprising a condenser and a loop together with a crystal detector, this set being so tuned that it will respond to the "second" modulation signal sent over a single ultra-short wave. In other words with the system here described, two or more programs can be carried simultaneously over a single wave.



the proposal; a method which requires the radio listener to procure a supplementary set. Here there is no longer a matter of theory, but one of work which has led to practical results.

Doubly Modulating an Ultra-Short Wave

In a lecture to the Heinrich Hertz Society, the author reported experiments performed some time previously, and described the technique of proper arrangements by which *an ultra-short-wave transmitter was simultaneously modulated by two different radio frequencies, which in turn carried different audio-frequency modulations.* After detection in a special rectifier, the radio frequencies, thus separated, were amplified at the receiving end; and successively tuned with a single radio set, or simultaneously heard with two connected radio sets.

The receiving apparatus then used is shown in Fig. 1; operation was on a three-meter wave, which was caught by the dipole (Hertzian antenna) arranged at the right. The demodulation of the ultra-short wave was effected in the double tube, shown in the picture to the right of the center. From here the two higher radio frequencies went to the two multi-tube receivers (which is visible in the picture at the top and at the left) and both signals could be heard at the same time.

Advantages of Multiple Modulation

What advantages are there in the use of an ultra-short wave modulated by many radio-frequencies, over the modulation of ultra-short waves with an audio frequency; *i. e.*, over the ordinary ultra-short wave radio method which has been followed for some time? The state of present technique, in the reception of ultra-short waves modulated at audio frequency is excellently characterized in an article by Dr. E. Busse, who has been for years the co-worker of the well-known short-wave specialist, Prof. Esau. Busse points out that, with very high frequencies, almost inevitably there arise fluctuations in frequency which are comparable with the narrow frequency-bands caused in modulation at audio frequencies. In reception, these fluctuations in frequency cause distortion and disturb

the adjustment. Busse sees the chief difficulty at the receiving end, and points out that the ultra-short-wave receiver is still in the beginning of its evolution.

The super-regenerative receivers thus far used for ultra-short-wave reception, and the apparatus with heterodyne reception occasionally developed in laboratories, are in fact very faulty. They are just like the regenerative detector circuit, which is still to be made practical for waves below 3 to 4 meters; here it is so hard to use that these wavelengths are useless for the radio listener. *All these well-known difficulties with the ultra-short-wave receiver disappear, if the ultra-short waves are modulated by high frequencies which, in turn, are the carriers of the desired modulation.*

First, suppose that the ultra-short wave is modulated by only *one* radio frequency; *e. g.*, the 300-meter wave. The width of the sideband which this wave creates in comparison to an ultra-short wave of 9 meters, is about 3%. The width is narrow enough so that even regeneration may be employed with success; and, on the other hand, it is great enough to make operation sufficiently simple. There is nothing surprising about these two facts; for the relation of modulating frequency to carrier fre-

quency is about the same as in normal radio waves. The fluctuations in frequency occurring at the transmitter are no longer of a percentage sufficiently great (as regards the high frequencies) to count; and therefore they produce neither disturbances nor distortion.

Existing Sets Can Be Used

The most important advantage of the intermediate employment of the radio-frequency modulation in ultra-short-wave reception may be seen from the fact that the *existing radio receiving sets*, whose operation is already second-nature to their owners, *may be used for ultra-short-wave reception.* The radio-frequency amplifier, at present available and, above all, the regeneration occurring in almost all tube receivers, will afford a very considerable intermediate-frequency amplification; which will increase the sensitivity of the set to a level which is required for certainty of operation in receiving.

From what has been said, radio-frequency modulation shows a great superiority, if only a single audio-frequency modulation is to be carried. Conditions are much more favorable (relatively speaking) in the transmission of several programs. With simultaneous modulation by several radio frequencies, the selective qualities of the radio receiver are also available for separating the different programs. Multiple modulation, which causes no difficulties at the transmitter, even with four to six different programs, will cause no complications with the supplementary receiving sets, in the case of several programs.

The interior of a supplementary set (all-electric), with an ultra-short-wave circuit and a double tube serving for both detection and R.F. amplification, is shown in Fig. 2. The roller switch (recognizable in the center beside the variable condenser) permits changing the antenna from normal radio reception, to ultra-short-wave reception and, at the same time, changes the house-current potentials. The supplementary set and its
(Continued on page 64)

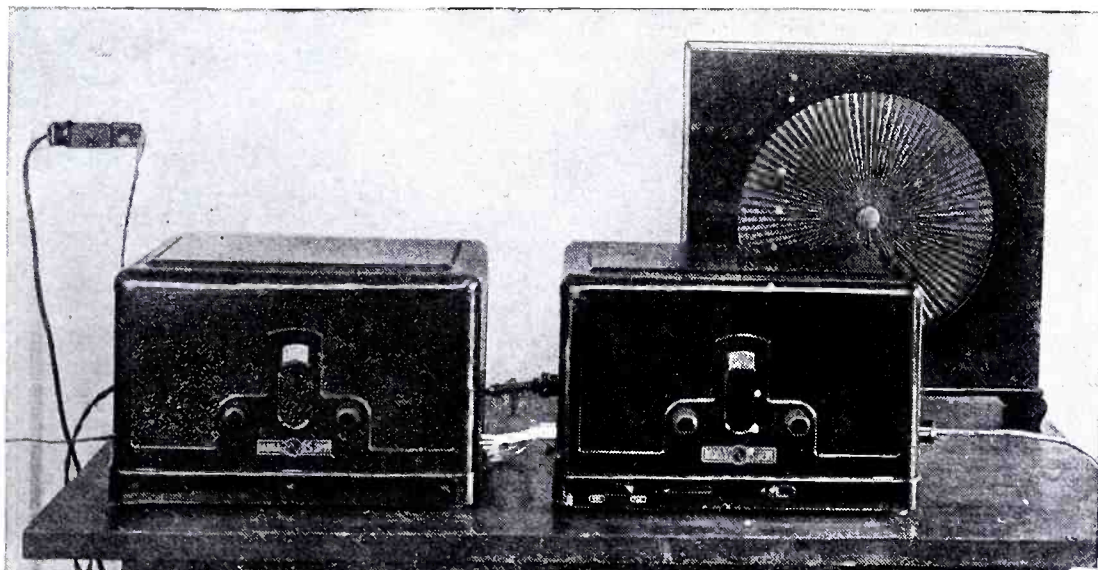

Fig. 4—Two radio receiving sets, one the usual set and the second, a supplementary receiver, which permits the reception of two programs over a single ultra-short wave.

1) that the primary of the filament transformer is connected to the convenience outlet or lamp socket in the usual fashion; but that it is also connected across the combined grid-plate element and one side of the voltage divider. The latter need be but an .02-meg. (20,000-ohm) resistor of the grid-leak type; since only "bleeder current" flows through it, and special wattage precautions need not be taken. It is practical to omit the cathode-"B"-resistor entirely.

The filter consists exclusively of a condenser, so the capacity should be large. This requirement is met by a dry-electrolytic 8-mf. condenser, with the cap (anode) connected to the rectifier's cathode and the lug on the can (negative), connected to the other side of the voltage divider, which is B minus.

It should be remembered that the cathode is positive; hence the other side of the voltage divider is negative. The negative of the rectifier will serve as the grid-return point for the converter's tube circuits; and no ground connection should be introduced from the receiver, as there is effective grounding through the capacity in the filament transformer.

Because the circuit is alive, as a source of both D.C. and A.C. voltages, it is desirable to isolate the aerial from any conductive coupling; which is done by placing a condenser in series with the aerial.

Since the cathode is positive, the "B+" voltage is taken from this point; and it will be more than 100 volts, if the A.C. supply is 110-volts. The extra voltage is dropped in the rectifier tube.

Automatic Regulation Is Obtained

Screen-grid tubes being used, a lower

voltage is required for the screens than for the plates; so the three screens are tied together, and a resistor, also .02-meg., is connected from the common screen lead to "B+". Therefore the effective voltage on the screens will be less than the applied voltage, by the voltage drop across the .02-meg. resistor, which is caused by screen current flow. Moreover, the screen voltage will be beneficially inconstant. When the signal is strong, and the plate current is lower than the steady no-signal value, the screen current also is lower. The screen voltage therefore rises (since less current causes less voltage drop in the series screen resistor), and a new measure of stability is achieved in the functioning of the screen-grid tubes. The amplification is held steadier, and fading effects are lessened.

There are four tubes in the converter: (1), radio frequency amplifier; (2), modulator; (3) oscillator, and (4), rectifier. The converter is triple-screen grid, the rectifier being, as stated, a 227.

The economical aspects of the circuit are apparent, since no extra windings are needed to constitute a power transformer of the more usual sort, while adequate filtration results from the use of only a condenser for this purpose. This is due to the low plate-screen current. If the current were high, the capacity would have to be higher than 8 mf. As it is, the circuit operates without any more hum than the usual well-filtered A.C. receiver of the finest console types. If a small "B" choke is provided, cathode to "B+," two 1 mfd, condensers at either end of the choke would provide sufficient filtration.

"This method of achieving the highly-

desired result of a short-wave converter with 'B' supply built in, at hardly any extra cost above what a converter would cost without 'B' supply, is one that should prove of striking benefit to the radio industry and radio consumers," said Mr. Bernard.

"The idea of resorting to a simple circuit to obtain a positive 'B' voltage economically has been in the minds of many for a long time. The problem presented itself to Mr. Anderson and myself principally in connection with a midget broadcast receiver, so small in size that it virtually fits in one's overcoat pocket—and yet there the receiver is, with all operating equipment, except speaker. The solution was found and, of course, it became apparent at once that this very same invention was just as suitable for 'B' supply in short-wave converters. Both of us had received many letters from intended users of converters who were worried as to how and where to obtain the independent 'B' voltage from various receivers; and answering these queries required much individual research. In some instances there was no satisfactory solution save to use 'B' batteries; but the present invention removes all causes for concern and works superbly.

"The invention has been embodied in the DX-4-All-Wave Converter, which tunes from about 30 meters to 600 meters, with two plug-in coils or, with an extra coil, from 10 to 600 meters."

Interesting Circuit of the Converter

The utter omission of any and all radio-frequency chokes will be noted. The couplets should be spaced ¼-wave-resistor of .02 meg., while the load on
(Continued on page 68)

You Hear S-W Stations on a B. C. Set With This Converter

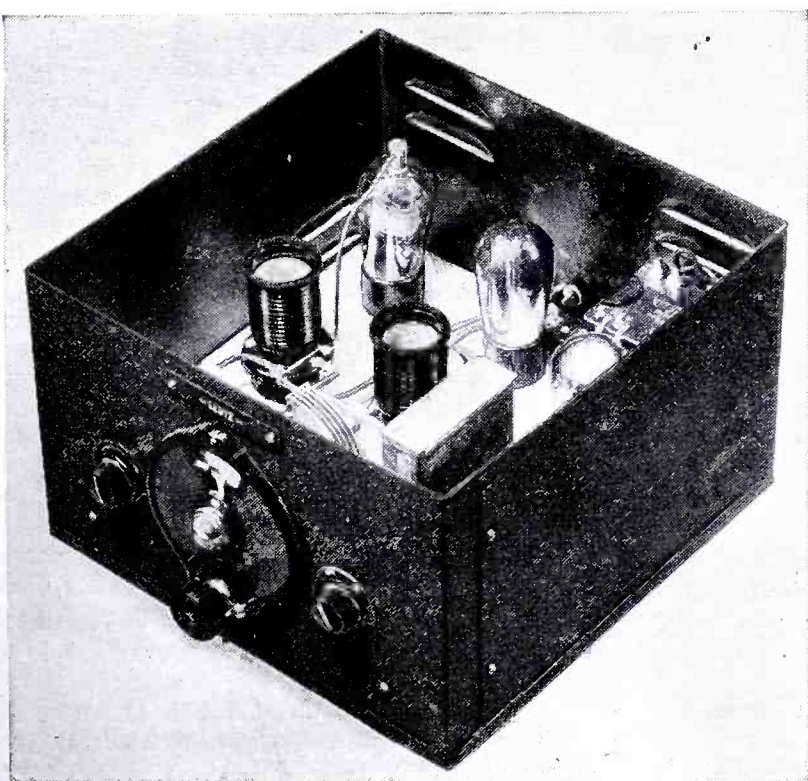

Appearance of Leutz adapter that makes short-wave reception possible with your broadcast receiver. It has its own "B" and filament-heater supply.

SHORT WAVE reception has definitely left the category of merely a pastime for nuts, cranks and wild-eyed experimenters. Short waves have donned evening clothes. They have gone "class." One can listen to short-wave signals without mussing one's hair, for the living room loud speaker earphones. Nor takes the place of need the devotee be on speaking terms with kilocycles, audio frequencies, capacities, impedance and other obstructions to normal enjoyment.

From the Altoona, Pa., atelier of C. R. Leutz,

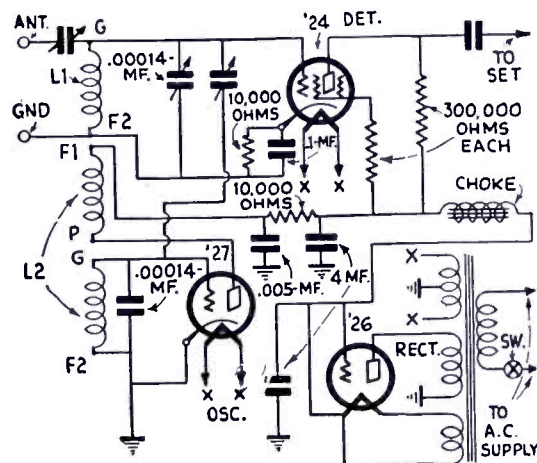

Hook-up of Leutz S.-W. adapter; only two wires connect to B.C. set.

emerges the super-heterodyne short wave adapter, a name we promise never, never, never to use again. We said it once only to show that it was a superhet, in case that means anything to you, and the word *adapter* merely means that you use it in conjunction with your own radio receiver. Take the aerial connection from your radio set, fasten it to the adapter, connect the adapter to the receiver with two wires and there you are.



Hungarian police officer talking over the short-wave radio-telephone system.

THE old-fashioned means of communication used by the Hungarian national police may be regarded as past their usefulness; since the telephone and telegraph lines leading to the telephone stations of the capital and the provincial cities do not ensure the necessary speed—and the efficient work closely connected with this—which must be regarded as the principal requirement of the modern police system. Thieves, embezzlers, and murderers nowadays flee by auto or airplane; so that in a few hours they may be outside the limits of Hungary, before the police could catch up with them, on account of the slowness of ordinary communication. There is the added point that, in many provincial towns and communities, the telephone system is in operation only in the daytime (on account of the general economy practiced and the financial condition of the country); also, there is usually trouble in getting a connection on Sundays and holidays. Under such conditions, hundred per cent certainty on the part of the police work is made difficult.

All this induced the authorities to make a fundamental change in the mode of police communication. At this point,

The Hungarian police radio system is centralized in the building shown in the picture at the right. Both short and long wave facilities are available.



Right: One of the outlying "post" radio bureaus connected with headquarters by the short-wave network, is seen in the photo. Both phone and code are used on the short-wave police system.

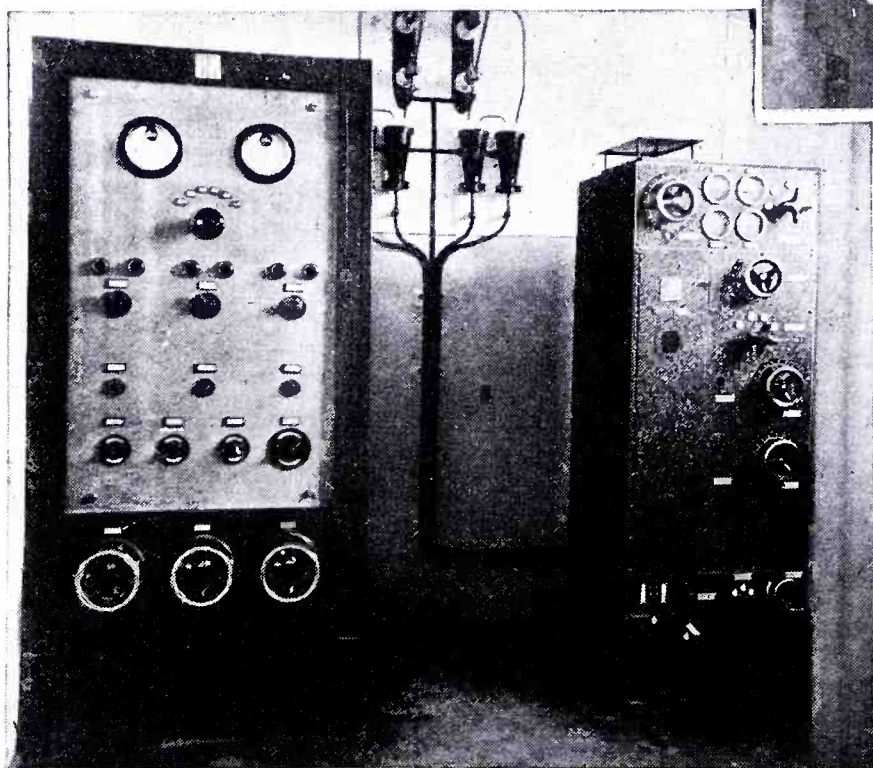

Picture at left shows transmitting equipment used by the Royal Hungarian Police system. Among the equipment installed is a 600-watt short-wave transmitter, as well as a 70-watt transmitter for telegraphy and telephony. In some of the smaller cities there have been installed 20-watt telegraph stations for return communication.

How Short

The accompanying article by the director of the Hungarian Police Radio Service, describes the apparatus successfully employed as an aid in the reduction of crime in that country. Short waves have been put to work in earnest in Hungary, as this article discloses. Various short, as well as long, wavelengths are utilized.

there arose the question, whether the expensive construction of a wire communications system could not be avoided by creating a radio network, since the latter appeared much cheaper. The solution of the problem did not, however, come about so easily, but on the contrary demanded very extensive investigations. After the completion of these, it was decided to constitute a radio service, which was to form a branch of the present European police radio system.

The Apparatus Installed

Many discussions with prominent foreign technicians were held, regarding the construction of a central short-wave transmitting station. After a rigid consideration of all branches of the problem, the contract was awarded to the Telefunken Company; with the proviso that the short-wave receiving apparatus,

Waves Cut Crime in Hungary

By DR. ANDRE SZENTIRMAY

Director Police Radio Service, Royal Hungarian Home Ministry

as well as the reserve current supplies, must be made in Hungary. This contract was approved by the cabinet and signed in the spring of 1929.

There have been installed:

(1) In the capital, Budapest, a 600-watt short-wave transmitting station, as well as a 70-watt transmitting station, for telegraphy and telephony;

(2) In each of the provincial cities of Szeged, Debrecen, and Szombathely, a 20-watt telegraphic station for return communication;

(3) Two hundred and thirteen receiving stations, one hundred and twenty of them in Budapest itself (one at each police sub-station) and ninety-three in the country (gendarme stations).

With the help of this modern system, the communication is carried on partly by telephone, partly by telegraph. The

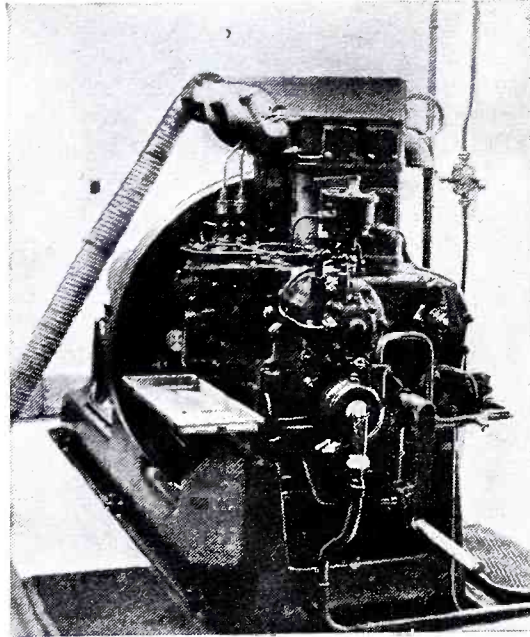

Above we see reserve generator driven by 24 H.P. Diesel engine, and at right, cooling device for the engine. The water falls in the form of spray through which the cooling air blows.

wave length. It is hung on a cable stretched between two tubular masts mounted on the roof. By a mechanical arrangement the antenna can be shortened or lengthened, according to the wavelength used.

Transmitter Easy to Inspect and Install

In the construction of the transmitter, especial stress was put on making the individual parts easy to inspect. The modulator, the control apparatus, the

(Continued on page 63)

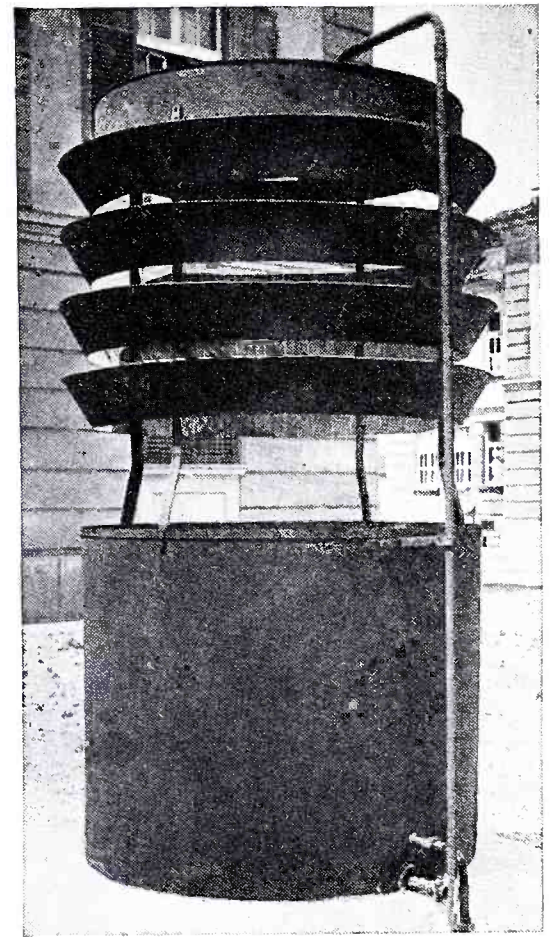

main station is always in telegraphic connection with all the police transmitting stations which are already members of the European radio network.

The station building of this system contains principally the mail, receiving, sending, and transforming divisions. In another room there is also a Diesel engine system as a reserve current supply.

C.W., Also ICW, and Telephony Provided For

The short-wave transmitter installed at Budapest is a two-stage, remote-controlled intermediate-circuit for telegraphy (CW or ICW) and for telephony. It has an antenna power of 600 to 800 watts (according to the wavelength) and covers completely the wave range from 15 to 90 meters (20,000 to 3,333 kilocycles). Its most important parts are the remote control transmitter, the main transmitter, and the modulation apparatus. The control apparatus is equipped with a tube of type RS 229; while the main transmitter uses two tubes of the same type. For keying and modulation there are two RV 24 tubes, and for pro-

viding key-close potentials two RV 218 tubes.

As an antenna there is used a simple radiator, which oscillates at quarter-

Above photo shows the receiving room for short-wave telegraphy. Receiving equipment for long as well as short waves is provided. C. W. as well as I. C. W. and telephony are provided for. Main power supply room of Hungarian Police radio system, showing motor-generators and control switch board at the extreme right.

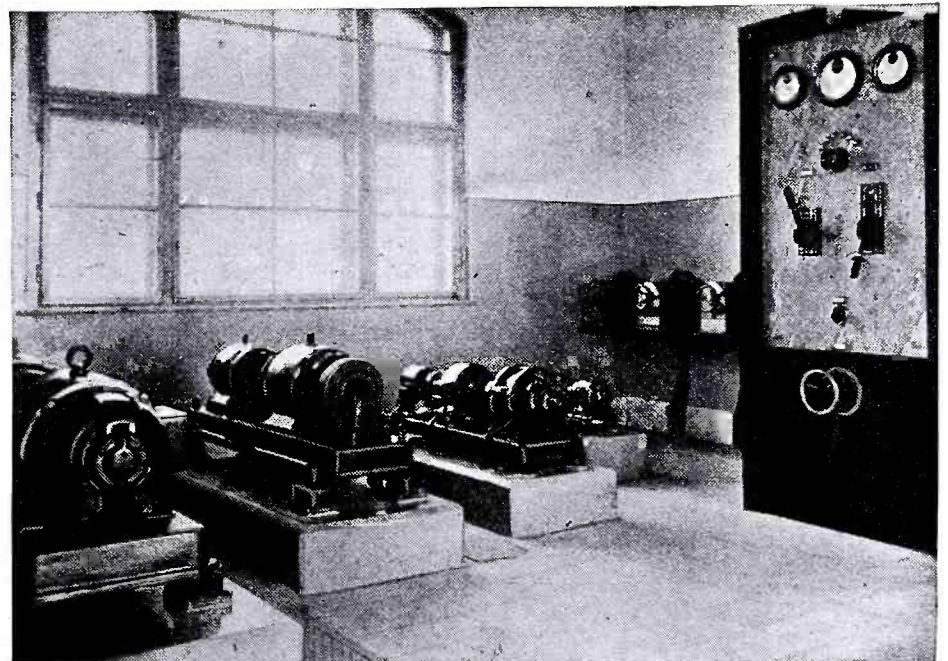

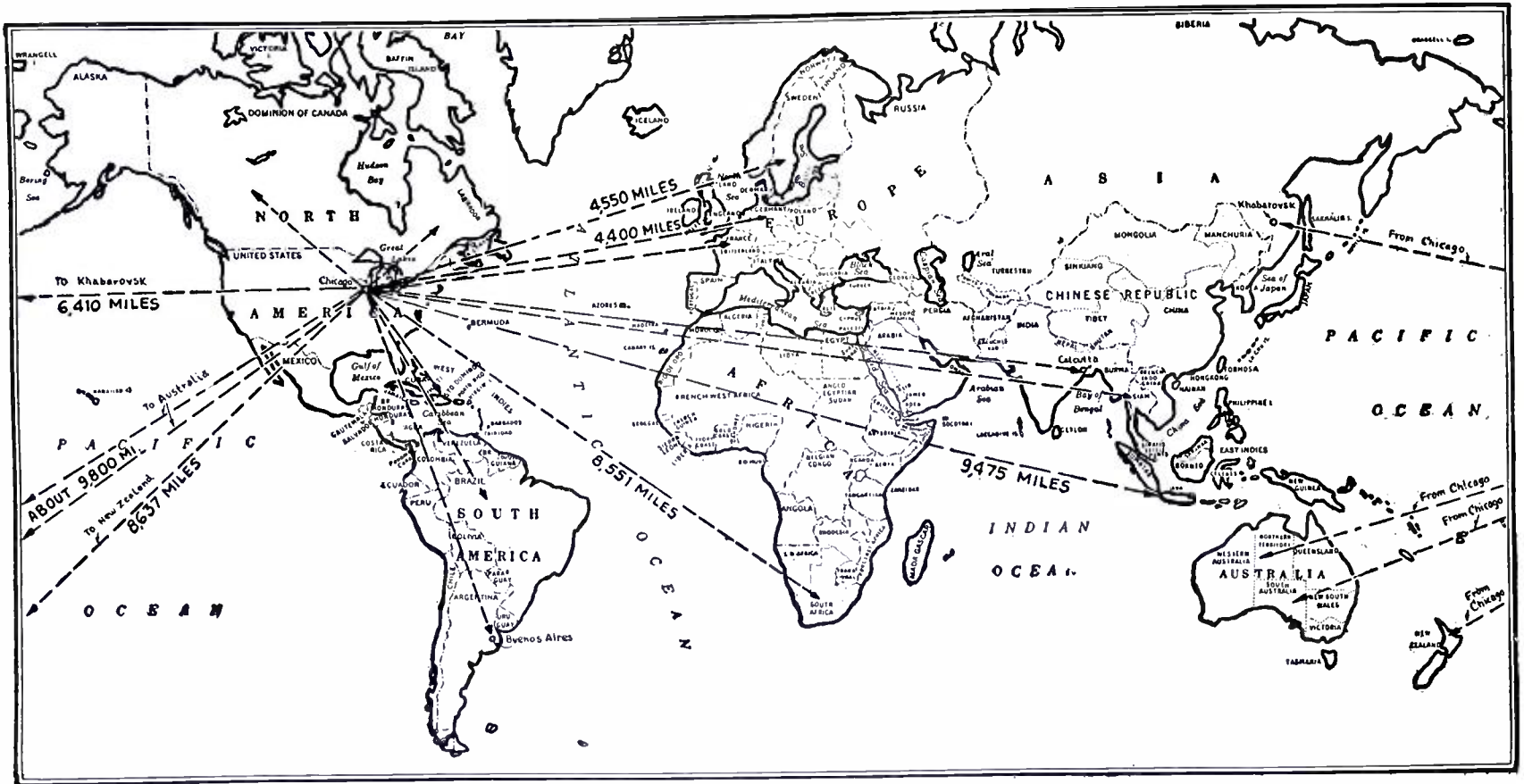

Map showing great distances over which short wave special test signals from W9XAA, Chicago, were heard.

Results of International SHORT WAVE TEST

By ARTHUR J. GREEN
President, International Short Wave Club

TO acquaint the general public with the merits of short-wave broadcasting and to arouse a greater interest in that form of entertainment, short-wave station W9XAA (owned by the Chicago Federation of Labor and operated on Navy Pier, Chicago, Illinois) broadcast a special *International* program on the night of October fourth, last. Complete details of this test have only recently been compiled, because of the tremendous range covered by the test and the time required for mail to reach the station from the most distant points where the program was received.

The program was arranged and sponsored by the *International Short Wave Club* of Klondyke, Ohio (an organization of short-wave broadcast listeners from all parts of the world, as a celebration of its first birthday). The International Short Wave Club, through its thousands of members, was enabled to spread the plans for the broadcast over all parts of the world and to short-wave fans everywhere.

Test Transmitter But 500 Watts

The station, W9XAA, is one of the smallest short-wave stations in the United States, its power being only 500 watts. Added to this, W9XAA is "sandwiched" between a number of high-

powered stations such as W3XAL, W8XAL and W3XAU. The wavelength on which this station is operated cannot be called a select wave by any means; for not only is it crowded but it is on a wavelength not generally credited with great distance-getting range. Altogether, the chances of reaching out a great distance with the program was very poor. In reading this report on the test, readers should keep in mind that station W9XAA was up against many obstacles

"The Short Wave is the
most important thing in
Wireless."—

Guglielmo Marconi

of momentous proportions; and it did not have a clear channel, a select wavelength or super-power. Considering this, the results obtained were simply amazing.

Test Signals Heard In All Parts of World

A 500-watt station on long waves, under the existing conditions outlined, would be heard perhaps 200 miles away from the station. **BUT W9XAA WAS HEARD IN EVERY CONTINENT!** Detailed reports were received from all parts of the world. Many listeners as far away as New Zealand gave detailed, word-for-word accounts of the entire eight-hour program. There is not the least possible doubt but that the program reached half-way round the world from Chicago with sufficient volume and clarity to allow the listener to copy each and every word spoken.

Preparations for the program took an exacting toll of time and expense. Letters describing the purpose of the test and giving details of the schedule were mailed out to hundreds of newspapers and magazines everywhere. These announcements were published in many languages in publications the world over. How many new batteries and tubes were bought especially for this program will never be known.

Valuable Awards

The reason for this great activity was due to the fact that a great many valuable awards were offered by the Inter-

(Continued on page 76)

The Short Wave Beginner

Fine Results With Tapped Coils

By RODERICK BERRY

Radio Operator, S.S.S.M. Spalding

denser was placed in series with the antenna and the grid coil when a capacity-coupled circuit was desired. With this tapped coil, a detector and two-stage audio hook-up was used, with a

Leads from the grid inductance must be kept as short as possible, and are brought out to a two-point switch on the side of the cabinet.

A .00016-mf. variable condenser was

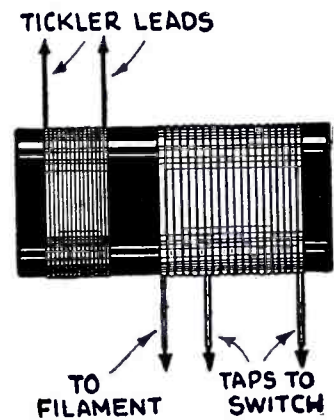
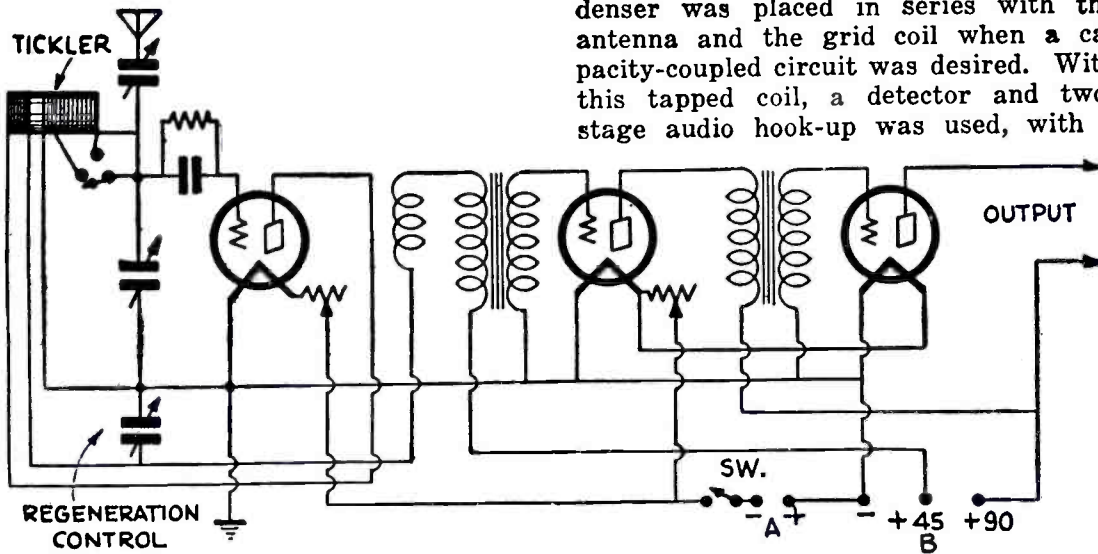

Wiring diagram and also detail of "tapped coil" construction for short-wave receiver, successfully using switch to change the wavelength instead of plug-in-coils.

AFTER reading the article in October-November *SHORT WAVE CRAFT*, concerning tapped inductances in the high-frequency receiver, I believe you would be interested in my own experiments with this type of inductance.

Various tests were made, using space wound, Lopez, self-supporting coils, etc.; but the most satisfactory results were obtained with coils made of No. 18 enameled wire space-wound on a 2½-inch skeleton form.

To successfully cover the band from 15 to 50 meters, 8 turns were used on the grid coil with a tap taken off at 3½ turns. The plate coil was wound with 4 turns of No. 22 cotton covered wire spaced ½-inch from the grid coil.

No Appreciable Dead-End Loss

This set has worked very satisfactorily and no less in volume is noticeable from dead-end effects. While going from Boston to Montevideo (Uruguay), Arlington (NAA), New Orleans (WNU), New York (HPN-WHD), and Rugby (GBR) were copied every night. As for broadcast reception, WGY, KDKA, and WBZ were heard while docked in Montevideo and consistently throughout the voyage. Many other code and broadcast stations from all over the world were logged with the same volume as when plug-in coils were used.

Both magnetic and capacity coupling were tried between the grid and antenna circuits, and about equal results were obtained. Twelve turns of No. 22 cotton-covered wire, wound on a 2-inch form, then made self-supporting, were used for the antenna coil when using magnetic coupling; and a midget variable con-

variable condenser to tune the plate circuit of the detector.

used across the grid coil, and a .00025-mf. in series with the plate coil.

Hints On the Beam Antenna

By J. M. REED, W6EIJ, WCDV

THE purpose of this article is to give a few fundamental ideas to help those experimenters wishing to construct a short-wave beam antenna and not knowing exactly how to start.

In the first place, it is necessary to decide what type of beam is desired. Perhaps the most common type is the so-called "Linear" or "Broadside" array. This consists of two or more antennas so spaced that their fields cancel in certain directions and reinforce each other in other directions; thus producing a "beam effect".

Fig. 1 shows an arrangement where "A" is the antenna, and "B" is the reflector; the arrow shows the direction of transmission. The distance between "A" and "B" has been found to be best when it is ¼-wavelength; this gives a phase difference of approximately ¼-period. A combination of one antenna and one reflector is called a "couplet". The couplets should be spaced ¼-wavelength apart, as shown in Fig. 1.

It has been found that, the longer the beam system (that is, the more couplets) the sharper will be the transmitted wave. This holds good up to a certain point where the system begins to transmit in other directions; however, the average person will not have enough ground space to reach that point. Up to sixteen or more couplets may be used without spoiling the directional effect.

Needless to say, considerable space is necessary for this type antenna.

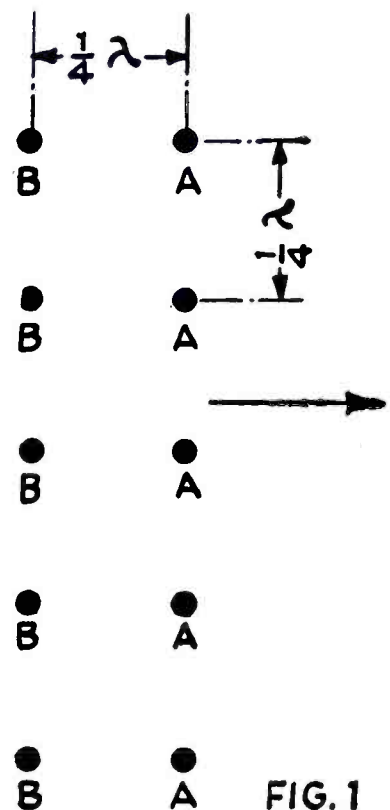

FIG. 1 Arrangement of simple beam antenna sections.

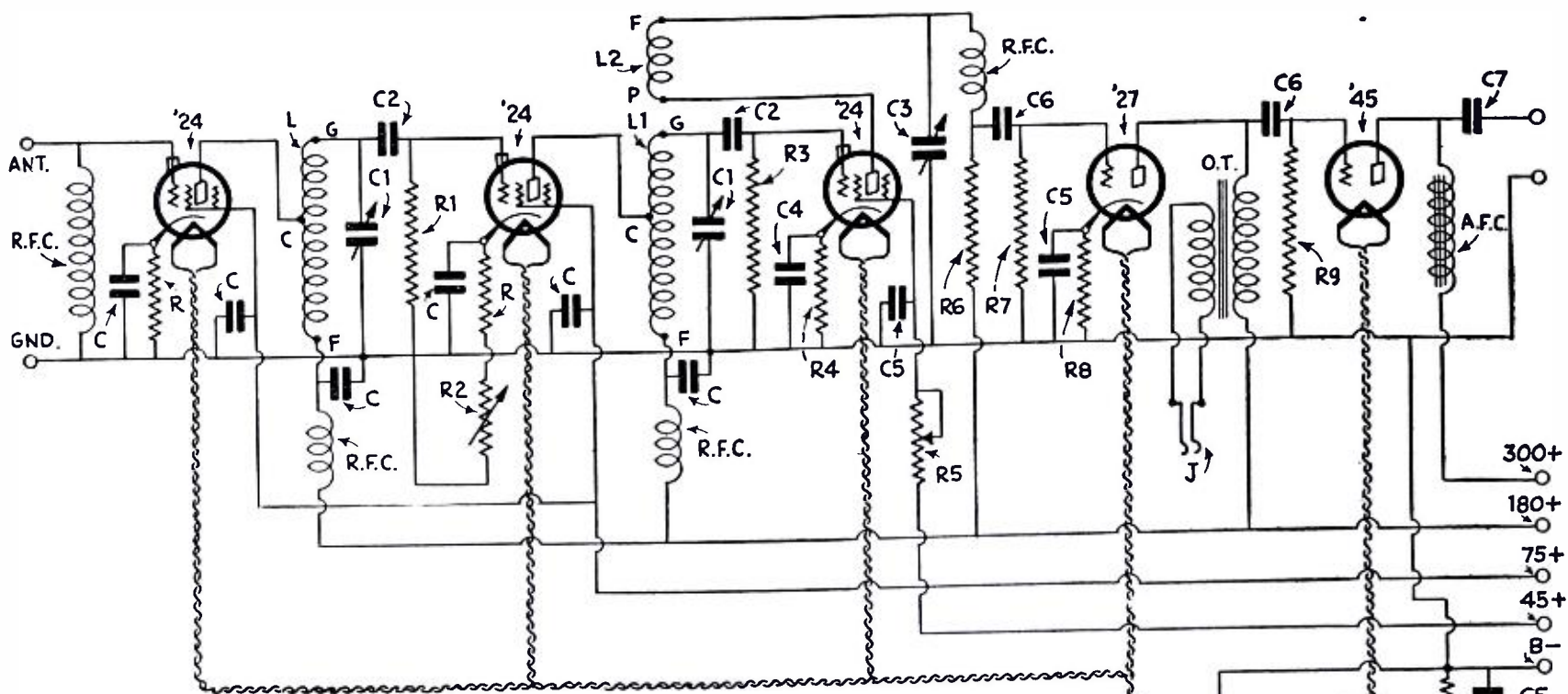

Fig. 1—Complete wiring diagram of the single control, short-wave receiver, here described by Mr. Tanner, W8AD. This receiver employs three shield grid tubes in the two R.F. stages and the detector. A first audio stage, which is resistance-coupled to eliminate "howling," employs a '27 tube, while the output stage has a '45 tube.

A SINGLE-CONTROL Short Wave Receiver

By R. WILLIAM TANNER, W8AD

MUCH has been written on the subject of short-wave reception, but little or nothing has been said in regard to multi-stage, single-control short-wave receivers. The entire radio profession seems to shun this most important subject as if it were an impossibility. With increased interest for short waves by "Mr. Average Man", something other than sets with an untuned R.F. stage is needed. Many receivers, now being offered to the public by manufacturers and custom set builders, consist of a separately tuned R.F. stage ahead of a regenerative detector. This arrangement gives a very high degree of both sensitivity and selectivity; but the controls are too numerous from the viewpoint of those having become accustomed to single control broadcast receivers.

The writer began a series of experiments, some time ago, to determine the possibility of ganging the tuning condensers in short-wave tuners. Although no permanent receiver has been constructed, enough has been accomplished to prove that such a set is not only possible, but very desirable as well, from both the Amateur and Broadcast listener standpoint.

Experiments That Failed

It might be of interest to the reader to learn something of the many experiments

tried. The first arrangement was a screen-grid R.F. and regenerative detector, employing capacitive coupling to the antenna, with a tuned impedance between the R.F. and detector. If the two tuned circuits were properly lined up for one set of coils, changing coils threw everything out of balance. Inductive coupling to the antenna and transformer

After all is said and done, the short-wave enthusiast becomes tired of twirling half a dozen knobs, in order to hear his favorite station, and Mr. Tanner's article describing a single control short-wave receiver, will undoubtedly command the attention of every ardent short-wave fan.

coupling between the R.F. and detector was tried; but this was worse yet. Tuning "holes" were found to exist with each set of coils, due to the absorption of energy from the grid circuit of the detector by the primary of the last transformer. In all cases selectivity was far from being good.

Connecting a small vernier condenser across the detector tuning condenser was a great improvement when impedance coupling was employed; it then being

necessary only to readjust the vernier for each set of coils. However, this did not seem like a logical solution to the single-control problem.

Considerable thought resulted in the idea that, by placing a buffer tube between the antenna and the first R.F. tuned circuit, any effects from changing antennas would be eliminated. Then, by using tuned impedance units with a tap somewhere along the coils for plate connections, some sort of balance between the tuned circuits could be obtained with a fair degree of accuracy and a worthwhile gain in selectivity.

This seemed to be worth a try-out; so a breadboard model was built up and then the troubles began to pour in. Many disappointments were experienced before a really workable receiver was developed. It was found necessary to measure the R.F. leads in the detector and then duplicate these lengths in the R.F. amplifier. This may seem like an unnecessary precaution; but this is not the case. Best results can only be secured in this way. Needless to say, the R.F. coils had to have exactly the same characteristics as those in the detector; this was accomplished by close-winding all the coils. For the 20-, 40- and 80-meter bands, the top turn was slightly spaced; variations of these served for balancing after the set was placed in operation.

"Buffer" Stage with '24 Tube Used

The final circuit arrangement is shown in Fig. 1. The design is such that circuit capacities are as near as possible equal in both the tuned circuits. The buffer tube is a '24, coupled to the antenna through a radio-frequency choke. The R.F. tube is also a '24, and another '24 is employed as a screen-grid detector. A space-charge connection would result in better tone quality, but the input capacity is higher. Throttle control of regeneration is employed, with a large condenser, .0005-mf. With this capacity only a small tickler is needed, less stray capacity being thereby introduced into the grid circuit.

Audio Amplifier

The audio-frequency amplifier is a conventional two-stage unit with a '27 in the first stage and a '45 in the second. Provision is made for head-phone reception when desired.

Volume is controlled by means of a variable high resistance connected in series with the buffer tube's biasing re-

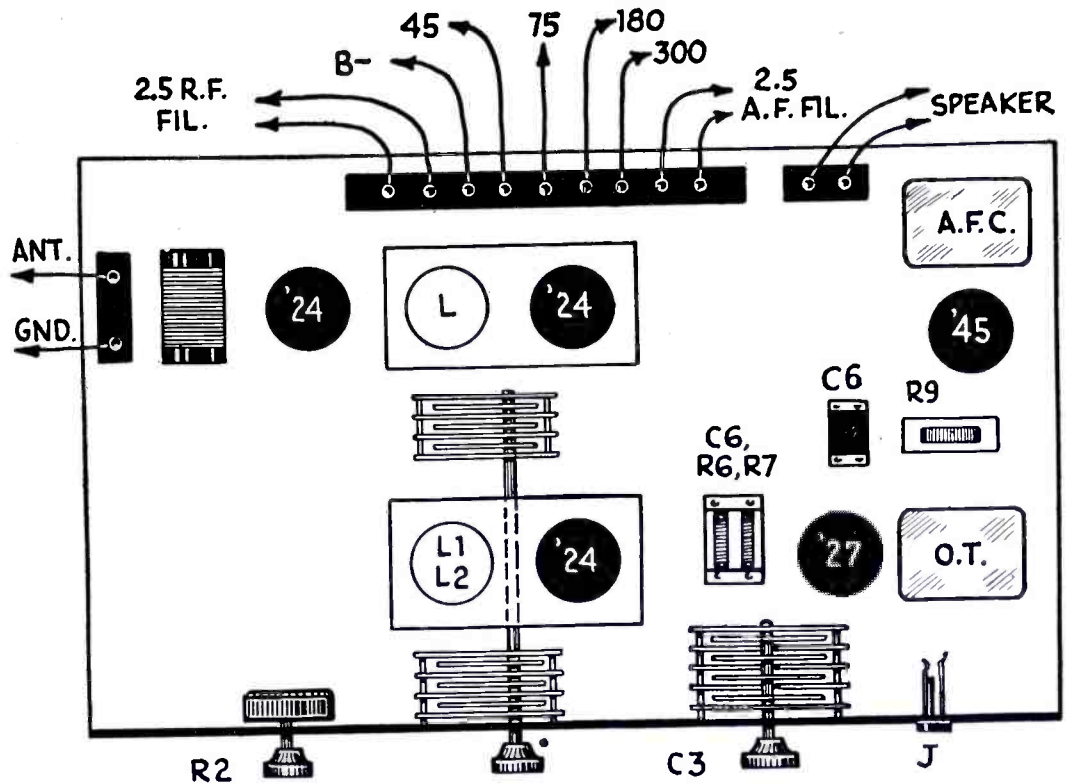

Fig. 3— Illustrates the author's suggested arrangement of the principal parts in the single control, short-wave receiver here described.

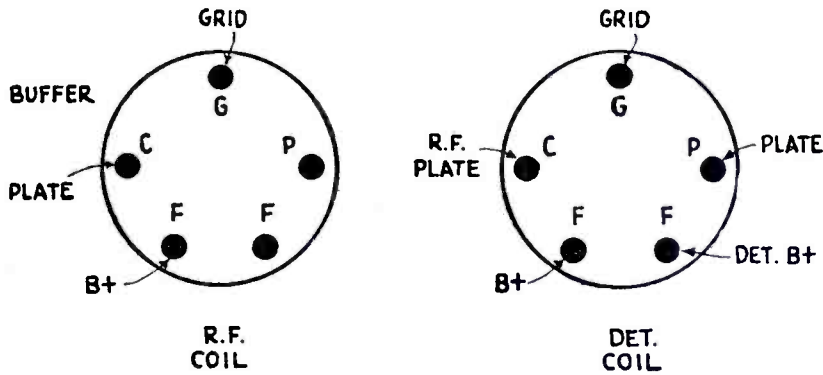

Fig. 2—At left shows circuit connection of the coil bases.

sistor. It will be noted that a resistor R5 is connected in the detector's screen-grid lead; this is of the semi-variable type and increased the sensitivity of the detector.

Now for some constructional details:

Plug-in Coil Specifications

The plug-in coils should be wound first. Eight Silver-Marshall type-130P Midget forms are required, four for the R.F. and four for the detector. A small hole is drilled in each form, just below the flange and directly in line with the "G" prong. In winding, the lead is passed through this hole and soldered to "G". Then the first turn is put on; after leaving a 1/8" space, the remainder of the turns are wound. When finished, paint the whole winding, except the spaced turn, with collodion, which dries in a few seconds. Then drill another hole in line with one of the "F" prongs, to which the lower lead is soldered. The corresponding "F" prong should be used on all of the coils. No. 18 D.C.C. wire is used on the 20-, 40- and 80-meter coils, and No. 24 S.C.C. wire on the largest ones.

The ticklers on the detector coils are wound with No. 30 to 34 wire, 1/8-inch from the lower ends of the grid coils; these are also painted with collodion to avoid change in characteristics. Many experimenters will hold up their hands in horror at the use of "dope" on the wind-

ings, but this has been found necessary; for sometimes the turns become loose, resulting in a change in both capacity and inductance. Make sure that the tickler lead next to the low side of the grid coil is connected to the remaining "F" prong; and the other lead to "P", which goes to the detector plate. If the polarity is reversed, no regeneration will be obtained.

Now in regard to the plate taps: The selectivity of this efficient short-wave receiver depends directly upon the number of turns between the tap and the low side of the winding. If the entire coil were in the plate circuit, selectivity would be very poor, especially on the two higher bands. A ratio of approximately 1 1/2 to 1 will generally be sufficient except, possibly, in locations close to some commercial or amateur short-wave station. Tapping the coils in this manner does not seem to reduce sensitivity to any appreciable extent. Circuit connections to the coil bases are shown in Fig. 2.

Buffer R.F. Stage Details

The R.F. choke, coupling the antenna to the grid of the buffer tube, consists of 300 turns of No. 36 enameled wire *scramble-wound* (meaning helter-skelter fashion) in five slots, 60 turns per slot. (The slots have been cut in a 3/4-inch wooden dowel, 1 1/2 inches long, which is then boiled in paraffine to exclude moisture; they are 1/8-inch wide and 1/8-inch

deep. This job must be done on a lathe but, if one is not available, the turns may be wound in a single layer, the length of the dowel then being somewhat greater.)

A negative bias is applied to the grid by the resistor R of 500 ohms. All by-pass condensers C have a capacity of 0.1-mf. The volume control R2 has a value of 100,000 ohms. It functions by reducing the gain of the tube when the bias on the grid increases with an increase in the resistance of R2.

A negative bias is applied to the grid of the tuned R.F. tube by a resistor of the same size as that in the buffer stage. The grid return is through a 2-megohm resistor R1. The coupling condenser C2 has a capacity of .00025-mf. The coil, tube, buffer tube's plate by-pass condenser, grid leak and biasing resistor are enclosed within a small shield box. The buffer tube's plate R.F. choke and biasing resistor and the screen-grid by-pass condensers are located underneath the baseboard.

The Detector

This tube operates as a grid-bias detector, not only to provide good tone quality but to increase selectivity, as well, by keeping the input impedance at a high value. The resistor R4 provides the negative bias and has a value of 10,000 ohms. As in the R.F. stage, a 2-megohm leak acts as a grid return. A semi-variable resistor R5 is connected in the screen-grid lead to increase the sensitivity of the tube. This has a resistance of 25,000 ohms and, once set for a given plate voltage, does not have to be touched again.

A .0005-mf. variable by-pass condenser C3 is employed as a regeneration control; it should, preferably, be of the straight-line capacity type, because of the greater ease of adjustment on the high end of the scale. The two R.F. chokes in this unit are exactly like that

(Continued on page 61)

The "HAM'S OWN" Receiver

By NORMAN B. KRIM

This short-wave receiver was especially designed by an amateur for amateurs—and in fact for all S-W "fans" who are looking for something a little different. This receiver has a "band-spreader," improved antenna coupling, a monitor circuit for use when transmitting, means to prevent howling and a range up to 700 meters.

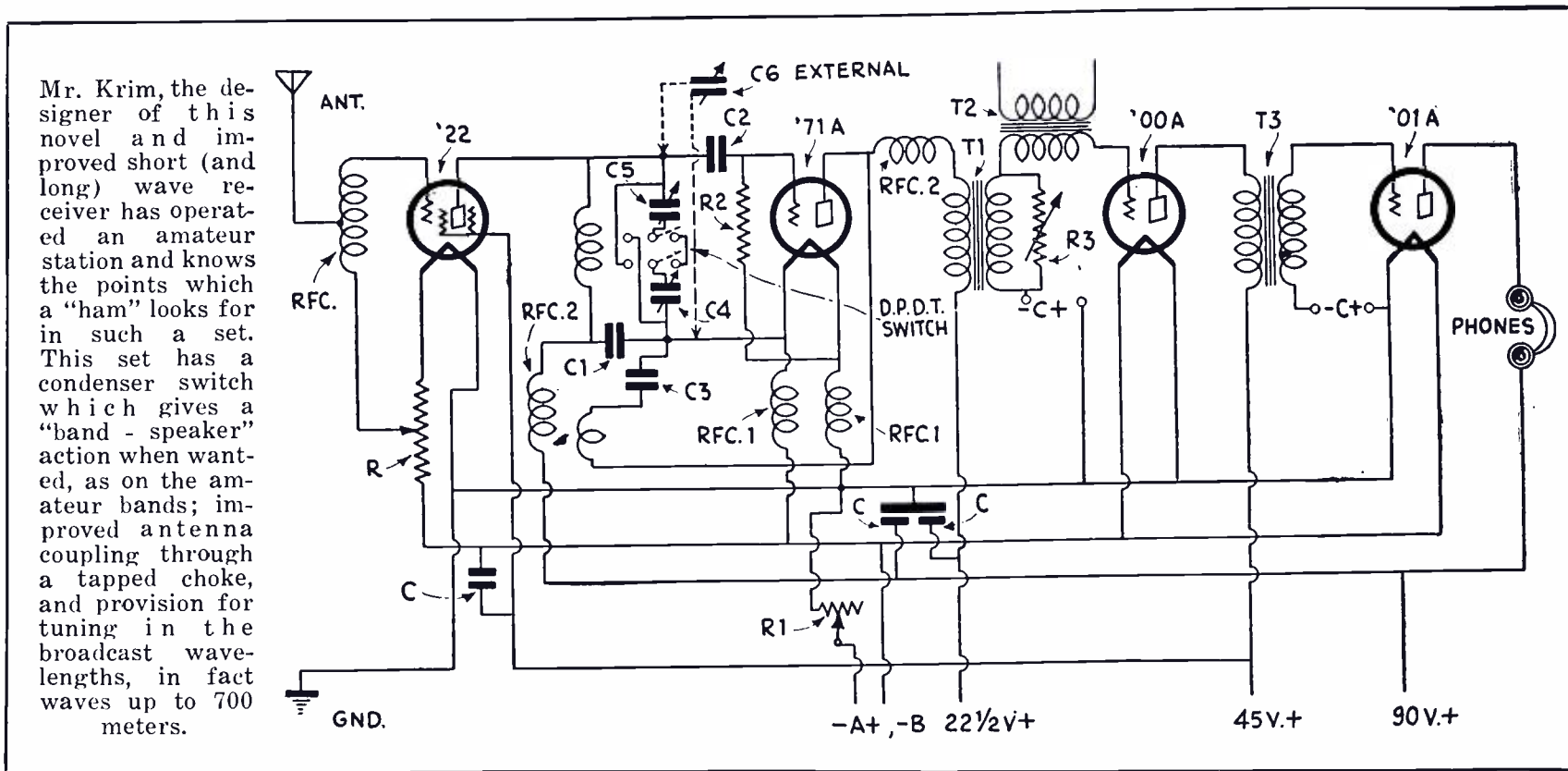

Mr. Krim, the designer of this novel and improved short (and long) wave receiver has operated an amateur station and knows the points which a "ham" looks for in such a set. This set has a condenser switch which gives a "band - speaker" action when wanted, as on the amateur bands; improved antenna coupling through a tapped choke, and provision for tuning in the broadcast wavelengths, in fact waves up to 700 meters.

EACH year short-wave receivers have been designed and redesigned but, with radio in its present transient state, we can not decide on any particular type. New discoveries and new uses are constantly changing the short-wave receiver.

Considering these facts, a design has been formulated with evident appeal for both the licensed and the unlicensed amateurs who are searching for a receiver which has a number of new features. The set in mind was intended primarily for the transmitting amateur, who wants a single receiver to cover efficiently the waves from seven hundred down to five meters. Other features are a high-gain untuned stage of screen-grid R.F. amplification, adequate band spreading, very smooth control of regeneration and, lastly, excellent "DX" possibilities.

For anyone to guarantee distant reception on short waves is absurd; but to claim that, for given conditions, more distant reception is possible is well in order. The receiver to be described has proved itself selective by intercepting seventeen different Australian signals in one morning's operation, in a New York City apartment house—equipped with everything electrical from elevator to the Frigidaire.

Detailed constructional information is, many times, useless because each enthusiast assembles things according to his own methods. Nevertheless, there are a few salient features which must not be overlooked, if satisfactory operation is to be expected.

A modern four-tube screen-grid circuit has been redesigned to satisfy my needs. Either A.C. or D.C. power supply can be incorporated; although, on ultra-short waves, direct current is found to be better because of the objectionable hum A.C. supply introduces.

In these modern days of high power and selectivity, the receiving antenna is apt to be neglected; but reception can be seriously impaired by a poor aerial. A well-insulated wire, about fifty feet long, will suffice. On short waves the set operates more efficiently without a ground; on long waves a ground connection is requisite for good volume.

Some Circuit Details

The antenna choke coil is novel, because the antenna current is fed to the center tap instead of to the grid end. The effect of this change is an excellent increase in volume. The choke-coil constants are found to vary considerably for different sets. Below twenty meters,

the efficiency of the entire R.F. stage is so low that the screen-grid tube is removed from its socket and the antenna is coupled to the detector in any one of the popular ways, either by induction, capacity, or directly per usual hook-up. The last method is employed here because the receiving antenna at the writer's station is a twenty-meter transmitting aerial. With such a condition, signal strength is increased considerably on harmonics of twenty meters where this system is used.

The detector circuit is heavily guarded, against radio-frequency current leakage, by numerous chokes and by-pass condensers. Taking this precaution is well worth while, for regeneration is smooth. A long lead to the "B —" is one of the little known causes of audio howl; by shortening this connection to a foot, or even two, and placing an R.F. choke in the lead this tendency is vastly reduced. The lead from the coil socket, to the grid condenser, to the grid must be extremely short. It is good policy to solder the grid condenser to these sockets. The grid leak should be mounted to the tube socket on metal clips, also soldered. All radio-frequency leads in the detector stage must be direct. Care should be taken to keep the grid and plate leads apart; for, the closer they

are, the higher the effective capacity in the detector tank and the more difficult it will be to operate on ultra-short waves. Grid leaks and grid condensers have not been found critical. A five-megohm resistance proved to be satisfactory with a .00015-mf. capacity. The higher the value of the afore-mentioned grid leak, the better the control of regeneration though at a sacrifice of sensitivity due to an excessive grid bias.

How Wide Tuning Range Is Covered

The two tuning condensers are .0001-mf. midgets. The vernier tuning dial is placed on one shaft; the other variable condenser is mounted behind the panel, very near to the first and to the detector unit. A Muter midget double-throw, double-pole switch is suspended on copper pieces drilled to fit the condensers. By means of the switch, the capacities can be put either in series or in parallel, affording not only amateur-band spread but a great extension on both sides of the assigned bands. Interlapping reception, on waves from five up to seven hundred meters, is the result. Another advantage lies in the fact that a set of commercial short-wave coils could be used for all the frequencies except the very high twenty-eight and fifty-six megacycle bands.

A large variable .001-mf. condenser is mounted in its own wooden box outside the receiver; a twisted lamp cord with two clips carries its leads to the set. This capacity is connected across the proper terminals for reception up to seven hundred meters, on the 200-550-meter coil, with more turns added to the tickler. Tuning, in this case, is effected by the large condenser.

The coil socket should be as sturdy as possible; the inner contact arms should also be very durable, for they are sub-

ject to many strains and stresses when changing plug-in inductances often.

A Monitor for Transmission

The audio system is conventional, except for the extra audio transformer. The primary is to be connected to the monitor or the audio oscillator. By inserting a double-pole single-throw switch in the filament leads of the receiver and either added circuit, the effect of putting the set off for transmission will automatically supply reception of the code which is being sent. This condition is almost required with a D.C. note and an automatic key.

A variable resistance across the secondary of the first transformer serves

inductance due to the variations in the wiring and other changing components. Some information on the very high-frequency coils will not be amiss.

Calibration of Ultra-Short-Wave Coils

The secondaries of the two smallest coils, for five and ten meters, are about one and a half and three turns respectively. The windings are on an old tube base and are spaced about one-quarter inch. The tickler windings should be placed in between these secondary turns. No accurate data can be given for these coils. The most efficient method to have the receiver on ten and five meters is to roughly calibrate it from a simple 201A oscillator, with any low plate supply, such as the house main; a Hartley circuit is excellent. Set the transmitter on twenty and listen to the receiver on forty where a note of the set will be heard if the apparatus is functioning as it should. (You will be listening, not to the transmitter's harmonic, but to the receiver's because an oscillator can not have harmonics over the fundamental wavelength.) Then adjust the inductance of the ten-meter coil until the transmitter note is heard.

This process can be speeded by making use of the following procedure: Wind about three turns on the grid coil and about the same on the tickler, after having removed the screen-grid tube, of course, and also the antenna which can be attached later. Adjust the tickler coil until oscillation is secured; if the note is not heard, turn the transmitter dial until it is. By noting which way the capacity was varied the coil can then either be decreased or increased until reception of the note is gained. The procedure for the five-meter coil is similar, except that the oscillator or transmitter is operated on ten meters.

In Next Issue
THOMAS A. MARSHALL
Famous S-W Expert, U. S. N.,
Tells How
To Build a
Super-Sensitive Receiver
for
Short Waves

as an adequate volume control. A sure cure for a howling audio system is the use of a 200A in the first stage; although no trouble in this respect should be experienced with this circuit.

The subject of plug-in inductances can not be treated fully here; since each set requires different numbers of turns to tune to the same wave, because each set has a different natural capacity and

New Midget Type Tuning Condensers

A SERIES of midget-type tuning condensers, ranging in capacity from 19 mmfd. to 322 mmfd., having the famous "Midline" characteristics, has just been developed in the laboratories of the Hammarlund Manufacturing Company, 424 West 33rd Street, New York City, where a series of straight-line capacity models has also been produced.

The smallest condenser is 2¾ inches long and the largest, 4 inches long. All "Midline" types are 2 inches wide, with plates fully extended. The capacity type is only 1½ inches wide.

Solid "bright-dipped" brass plates are used in all models; all plates are well spaced and soldered, the stator being soldered to slotted brass bars and the rotor to a slotted brass shaft. A continuous brush contact of phosphor bronze is provided, thus affording perfect contact throughout the entire capacity range.

There are also end stops, so that neither rotor nor stator plates can be damaged by jamming. A set-screw is

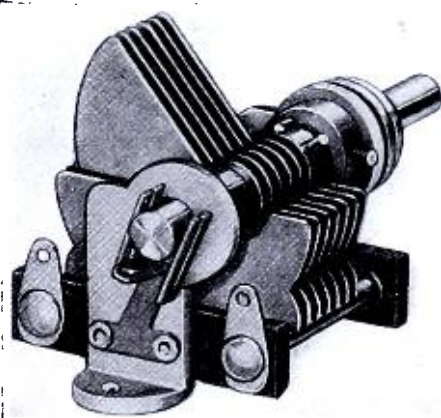

The newest midget variable condenser being supplied for manufacturer's use only at present, by the house of Hammarlund.

provided for locking plates in any position permanently; this is ideal for balancing purposes, as well as for capacity bridges, oscillators, beacon sets, etc.

No screws or nuts are used anywhere

in the construction of this condenser, soldered eyelets being employed. Thus all possibility of internal vibration is eliminated. This is an excellent feature for airplane and automobile sets.

The models are made for both clockwise and anti-clockwise operation, and for base or single-hole panel mounting. The shaft is ¼-inch in diameter.

To further increase the efficiency of the unit, the special Hammarlund low-loss insulation "Parmica" is used. The rotor rests in small, aluminum end-pieces, which are grounded and also serve as a base mounting.

The compact and high-capacity features also make this condenser especially useful for antenna tuning, for midget broadcast sets, and short-wave receivers.

The "Midline" type are known as the MC-(number of plates)-M type and the capacity as the MC-(number of plates)-S type. They are made in the following capacities: 19.2 mmf.; 34.2 mmf.; 49.2 mmf.; 78.6 mmf.; 93.6 mmf.; 100.2 mmf.; 138. mmf.; 198.6 mmf.; 242.4 mmf.; 294. mmf., and 322. mmf.

Ultra Short Waves

Investigations in the Field of Ultra-Short Waves

By DR. KARL STOYE
(Berlin)

THE writer had previously stressed the significance of the tuned plate choke of the receiver tube in the ultra-short wave super-regenerative receiver. Both the ability to oscillate and also the volume are very considerably improved by this method. Dr.

Ultra-short waves are commanding world-wide interest today—read the latest European report by Dr. Stoye, a leading German expert.

long as you like, and thus gets away from the ground, just as in the case of the ultra-short waves. For distances up to one or two miles, *no antenna* was used with either transmitter or receiver. The coil diameter used at both sending and receiving end was 8.5 cm. (3 3/8").

With a wavelength of 6.80 meters, successful transmitting could be carried on over a distance of 4.8 to 6 miles. The single-wire antenna of the transmitter was stretched 8 meters (26 ft.), above the ground. At high points the sound volume of reception was still good; but in the valleys at this distance the wave entirely disappeared. It was evident that the reception was louder, the higher the receiver was placed above the ground. Even at a short distance, reception stopped behind closely planted orchards; strong absorption of energy was also observed in the midst of wooded places. Just as, on many days, stronger absorption was observed at 3.40 meters, so also this occurred at 6.80 meters. *These were the days on which the sunshine was very strong.*

These experiments were conducted with a single-tube hook-up; it is now being used for the 2-meter experiments also.

If you have read the epoch-marking article elsewhere in this issue, describing the remarkable tests with 7-inch waves over a distance of 21 miles across the English Channel, you will begin to see that the application of these extremely short waves is indeed very near. Greater distances can be covered by wave reflection and refraction.

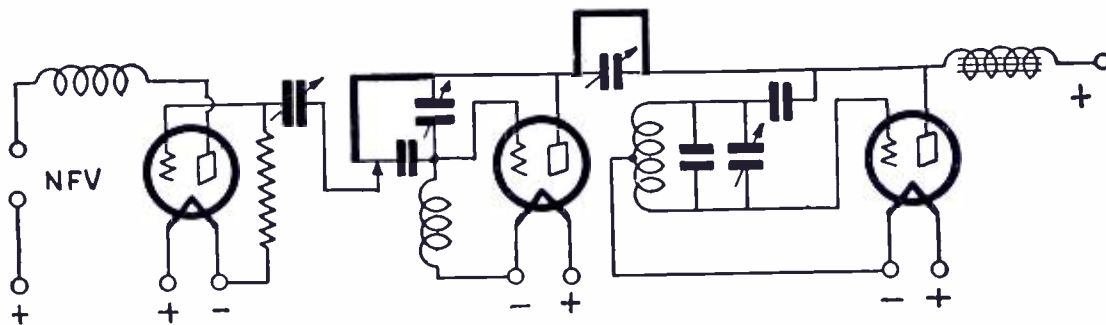

Fig. 1—Diagram of tuned plate receiving circuit described in text.

E. Busse had also directed attention to the tuned plate circuit, the receiving sets having been rebuilt according to the diagram in Fig. 1. The tuned plate circuit overcomes any unwillingness of the receiver to oscillate—such as has happened frequently in the past. Adjusting the receiver is in no way difficult; even with waves of about two meters, the receiver has proved a brilliant success. The rheostat of the receiver tube is put on the panel. The coils are set at 90 degrees—not to close—with respect to one another. Good neutralizing condensers were used to tune the plate intermediate circuit. Fig. 2 to 5 give views of the two receivers used.

As a transmitter, for investigating the properties of the waves of 6.80 and 2.25 meters, the push-pull and single-tube hook-ups were used. The push-pull transmitter for waves of about 2 meters was built with tuned filament chokes (see Fig. 6).

For the wavelength of 6.80 meters a single-tube hook-up was used, called by various names in the literature of the subject; see Fig. 7 for the diagram. Fig. 8 shows the transmitter as seen from above. Fig. 9 shows another transmitter of the same construction for waves down to 2 meters. A single-wire Hertz antenna was employed, with direct coupling on the plate side, which produced very good results. This antenna has the great advantage that the wire can be made as

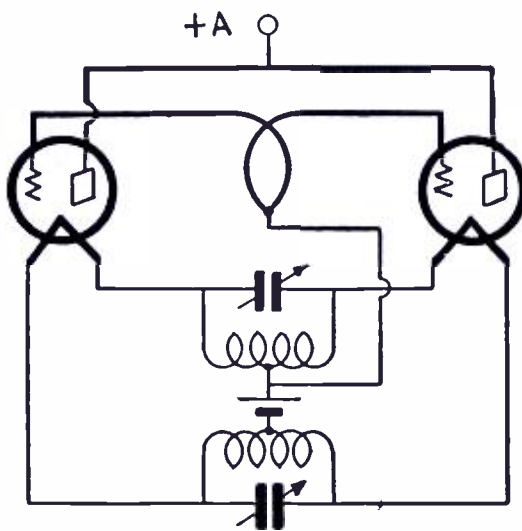

Fig. 6—Push-pull transmitter for 2 meter waves, with tuned filament chokes.

NO WHERE ELSE
can you find the latest data,
with diagrams, on
"ULTRA-SHORT WAVES"
More articles on U.S.W.'s
in next issue.

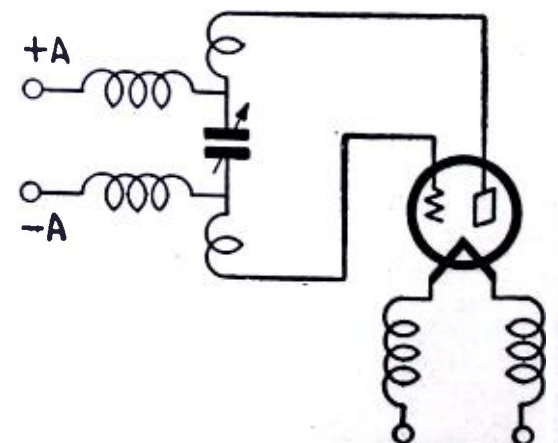

Fig. 7—For a wavelength of 6.80 meters a single tube hook-up was used.

Some Views of Dr. Stoye's Ultra-Short Wave Apparatus

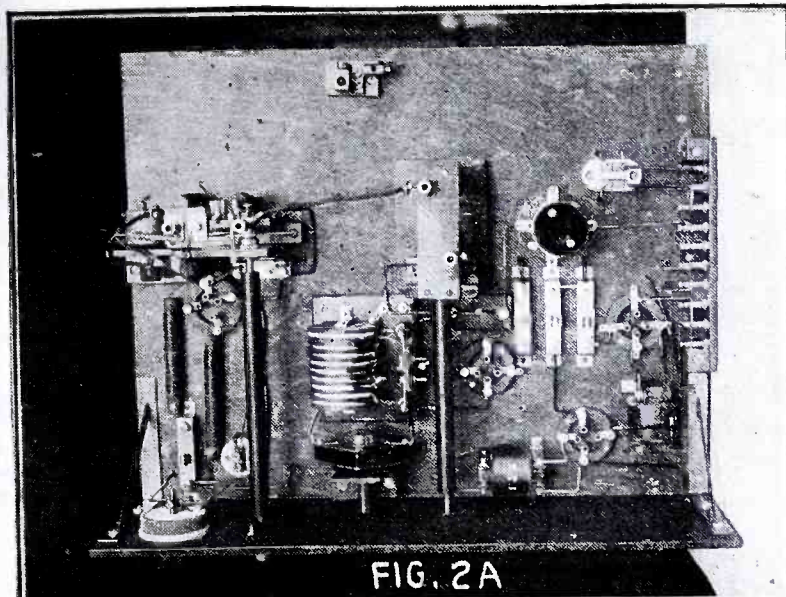

FIG. 2A

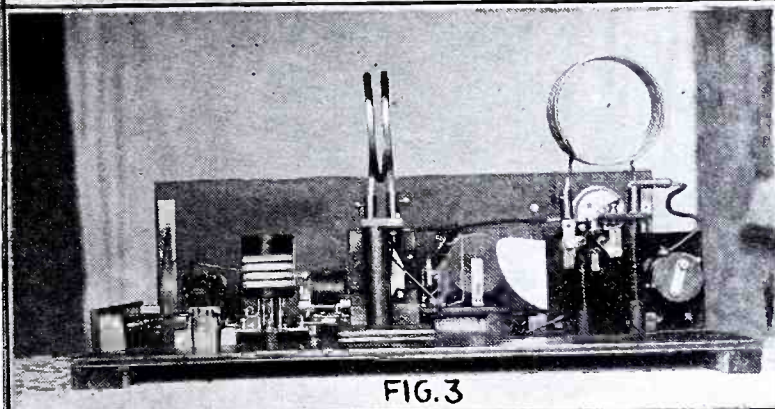

FIG. 3

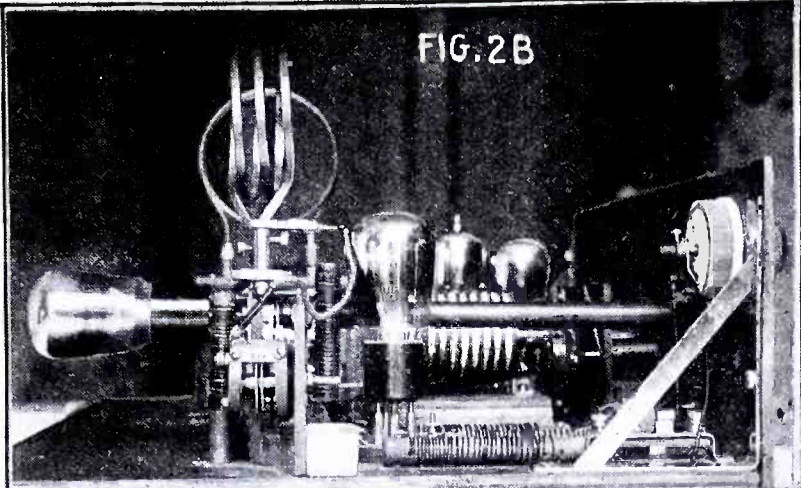

FIG. 2B

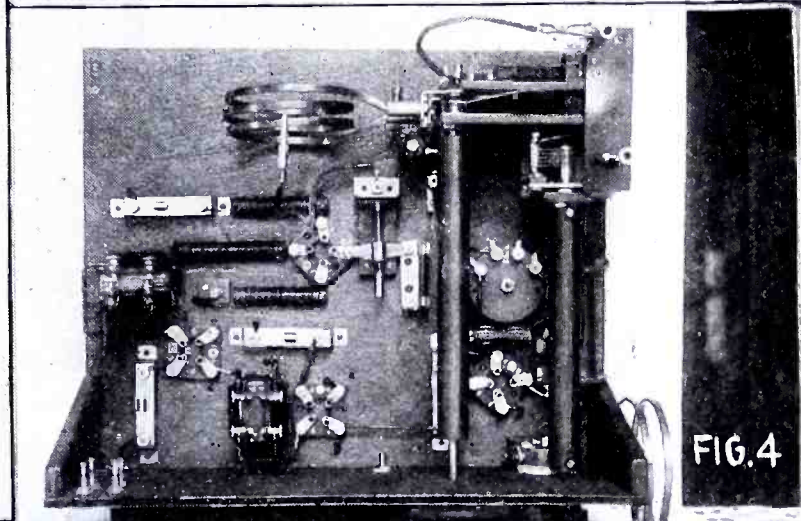

FIG. 4

Fig. 2—A, shows Dr. Stoye's super-regenerative receiver, Model 1, for operation on waves of 2.25 to 10.00 meters, as seen from above. Fig. 3, same set from the back; Fig. 2-B, same set, side view. Fig. 4, receiver, type 2, of modified and more compact design.

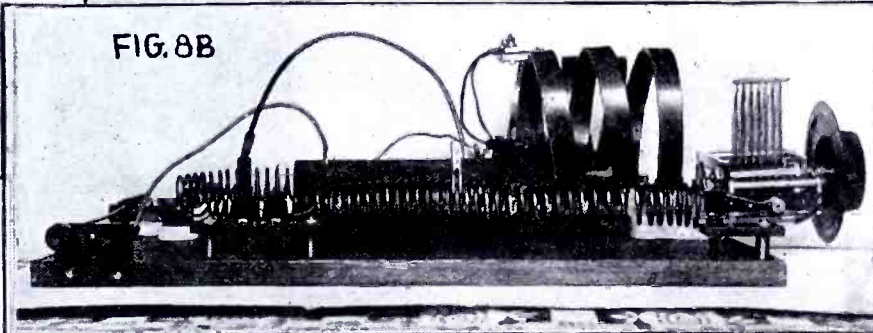

FIG. 8B

Fig. 8B—Above, shows side view of five to eight meter U. S. W. transmitter.

Fig. 8A—Illustrates five to eight meter transmitter, fitted with tunable chokes—top view of set. The tunable choke feature is quite a distinct advance in short-wave set design.

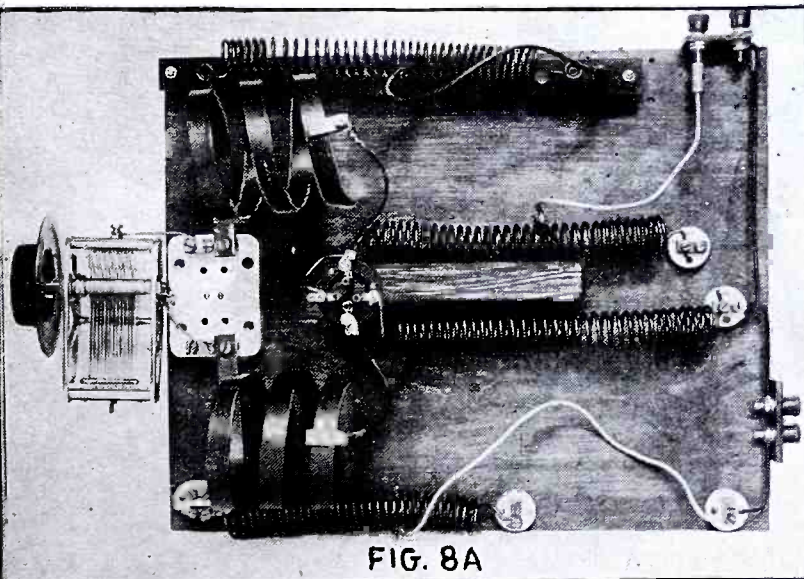

FIG. 8A

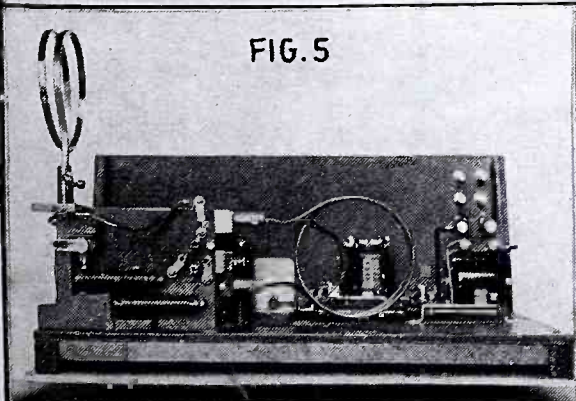

FIG. 5

The apparatus shown in Fig. 5 at the left is a side view of Dr. Stoye's super-regenerative receiver, model 2, designed for operation on 2.25 to 10.00 meter waves. Fig. 9, at right, shows top view of Dr. Stoye's 2.5 to 3.5 meter ultra-short-wave transmitter.

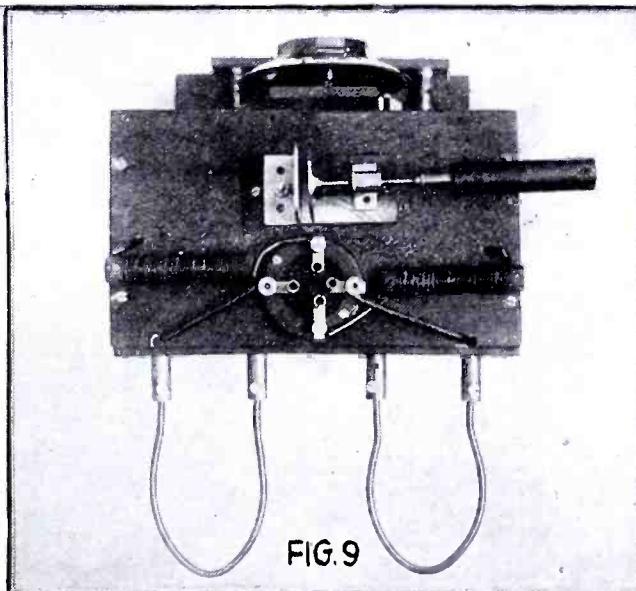

FIG. 9

GETTING STARTED on 5 METERS

By E. T. SOMERSET, G2DT

A short time ago the successful transmission and reception of ultra-short waves took place across the English channel, a distance of about twenty-one miles. Therefore every earnest student should at least study the transmission and reception methods used for these wavelengths. We are fortunate in presenting this very valuable and practical article on five meter operation by Mr. Somerset, one of England's leaders in this work. Mr. Somerset operates station G2DT.

IT IS, unfortunately, only too true that very few people are busying themselves around frequencies of the order of 60,000-kc. (the 5-meter band), in spite of the prevalent belief, already mentioned by the editor in previous issues, that it will be in these regions that radio of the future will lie. Amateurs have a very great opportunity to "tell the world" about themselves, if they will only concentrate a little more time into investigating the *ultra high* frequencies.

It is rather generally assumed that elaborate and perhaps costly apparatus is required; whereas this is not the case at all since, very often, apparatus already on hand can be altered and adapted for use on these frequencies. Any type of variable condenser may be used for tuning, provided its maximum capacity does not exceed 50-mmf.; but, where only a small frequency coverage is desired, it becomes necessary to resort to something similar to that shown in the photograph (which the writer de-

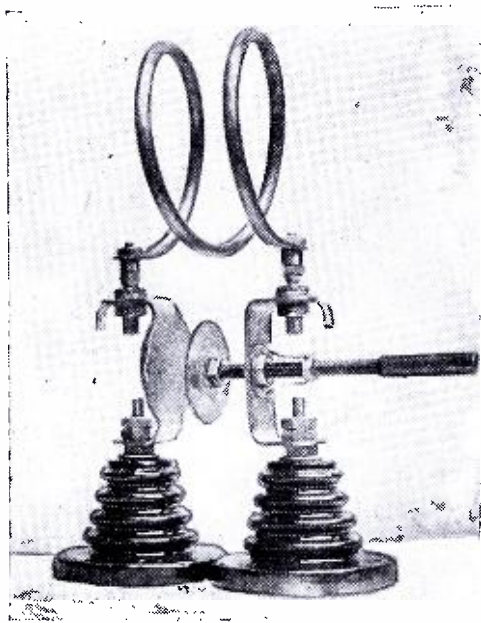

One method of insulating and supporting an ultra-short wave condenser and inductance.

signed and made for covering only 7 centimeters in the amateur 5-meter band) in conjunction with the inductance plainly seen. It is quite easy to make and the rotor consists of a 1½-inch diameter copper disc, which is fitted to a threaded brass rod which screws through a bearing (also threaded), and thus can be made to approach the stator or stationary disc. The inductance is made from No. 8 gauge copper wire and is 1½ inches in diameter and spaced ¼-inch between turns. On the threaded rod is fitted a bakelite extension shaft, 8 inches long; and this goes to the panel of the receiver, to be driven by a large size General Radio Co. knob. No vernier dial will be necessary, if a fine thread is cut on the brass rod.

Reverting to standard condensers again; these should preferably be small in bulk; and the writer suggests the small Hammarlund of 16-mmf. maximum capacity as a suitable type.

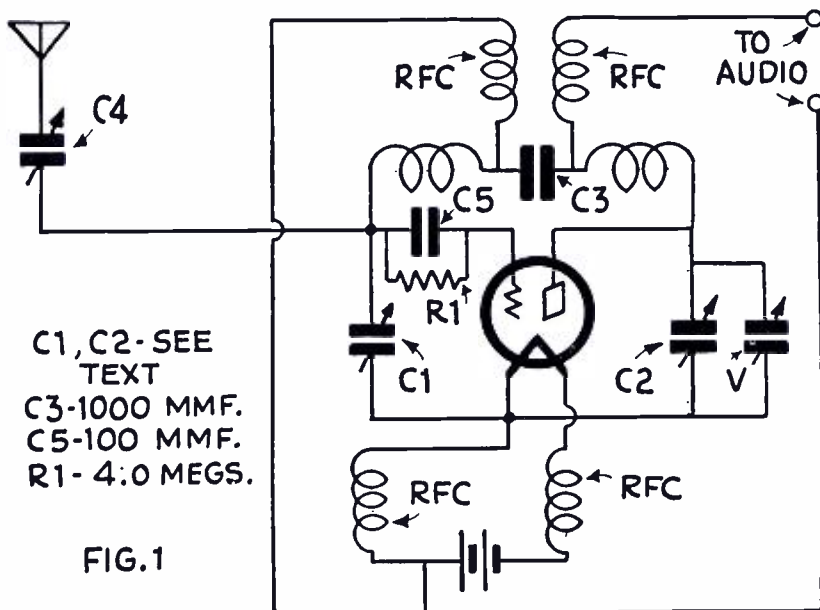
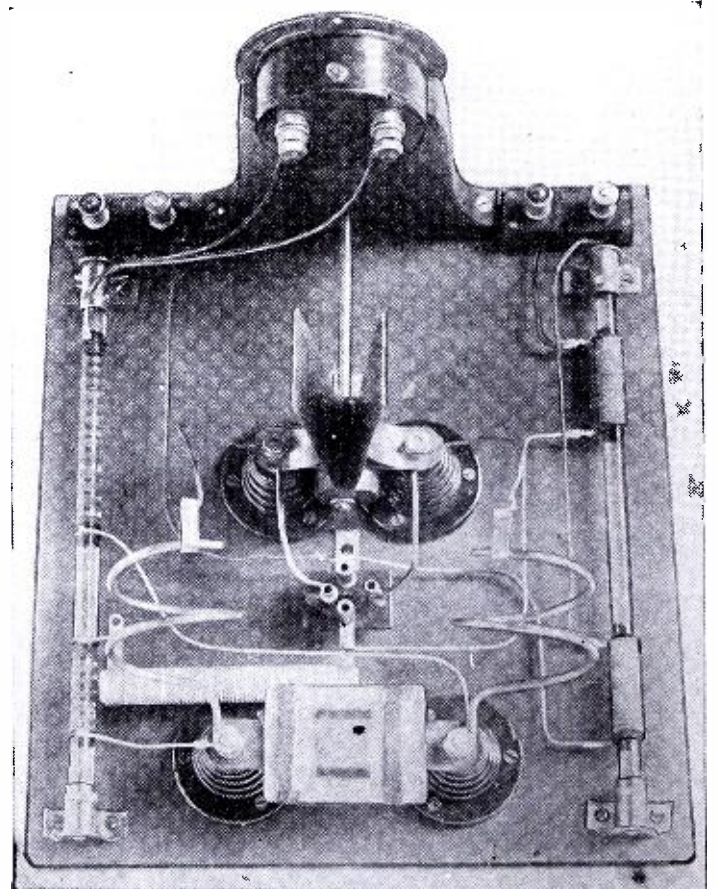

Fig. 1—Above, shows five meter, Colpitts short wave receiver.

Top view of Mr. Somerset's five meter transmitter. Note plates of variable condenser at center of base, which are operated by a cam connected with insulating shaft and knob on the front panel.



Perhaps the most tricky components for use in the 5-meter band are the radio-frequency chokes. After considerable experiment, the writer recommends chokes of 80 to 110 turns of No. 36 D.S.C. wound to a length of 2 inches on 1/4-inch Pyrex tubing. In the filament leads, a suitable choke will consist of 70 turns of No. 20 D.C.C. wound on a 1/2-inch Pyrex tube.

Tuning inductances will be of from two to four turns, self-supporting, one or two inches in diameter, according to circuit and losses introduced by layout, wiring, etc. Always use fairly heavy wire for rigidity.

It is not generally necessary to remove bases from tubes; but, when possible, connections should be soldered direct to the tube legs. The grid condenser in the receiver should be of from 50 to 100 mmf. capacity. For all other condensers, .001-mf. is a satisfactory value.

As regards the circuit for the receiver the Ultra-Audion is very satisfactory (see SHORT WAVE CRAFT for Feb.-March, wherein the writer described such a receiver). So also is the well-known Reinartz-Grebe, but it is strongly advised to break away from the usual and, in full confidence, the writer recommends that the Colpitts be tried. This is seen in Fig. 1.

Practical Problems Encountered

The tuning capacity is made up of the condensers C1 and C2 in series and here a problem crops up: Shall we make C1 or C2 the tuning control? Any alteration of one condenser would necessitate a simultaneous alteration of the other. The following method is eminently satisfactory. The "vernier" condenser V is used for tuning and the band is covered in steps of approximately 15 centimeters, or about 1,600-kc. Supposing it is desired to tune from 5.2 to 5.3 meters, condenser V is set at the center of its range and the ratio of C1 to C2 is adjusted to give the strongest oscillation on 5.25 meters; their settings are marked for future reference and the job is done. Regeneration control is obtained by means of the series aerial condenser C4 and this is very satisfactory but, if desired, the usual variable resistor in the "B" supply lead may be used for regeneration control.

No difficulty should be experienced in constructing such a receiver if it is borne in mind that very high frequencies are being dealt with and that, therefore, care must be exercised in layout and wiring to keep wires carrying radio frequencies well away from those at low potential. If "threshold howl" is encountered, careful adjustment of the "A" current and the use of a parallel-fed audio amplifier will usually effect a cure, but, if not, try insulating the batteries and standing the receiver upon stand-off insulators. To obtain a silent background it is necessary to experiment with different grid leaks and to see that the rotors of variable condensers are not making a noise by keeping them clean and greased. Unsteady signals can generally be cured by

Fig. 2— At right, shows five meter ultra-audion, short wave receiver, of the type tried out successfully by the author, who is one of England's leading experts on ultra-short waves, operating experimental station G2DT.

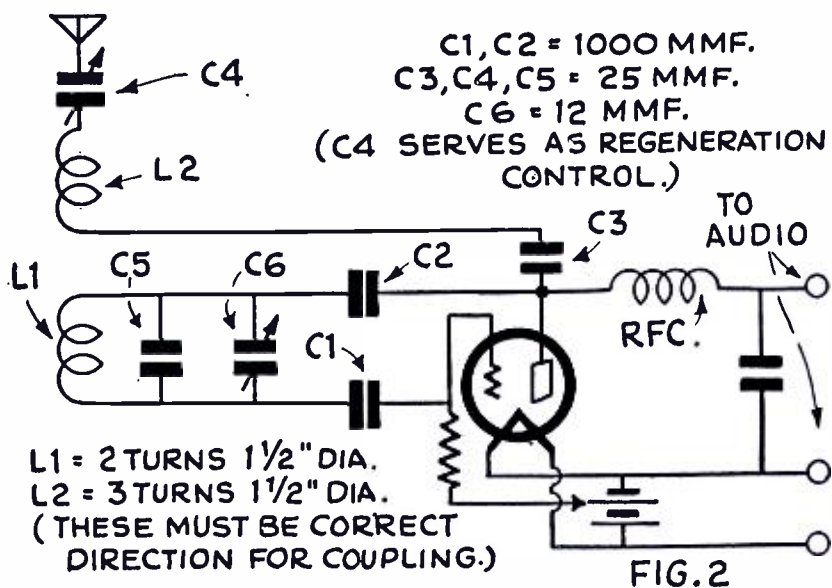

mounting the receiver upon sponge rubber.

Having made the receiver, the first thing will be to ascertain upon what wavelength it is working; and a very simple means will be described first. Connect up an aerial of 8 feet of wire and "feel" for a point where the band may be brought close to the aerial (with the detector oscillating) without upsetting the frequency. The distance from this point to the free end of the aerial, multiplied by four, will give the approximate wavelength in meters. An accurate method of frequency measurement appears at the close of this article.

Should the would-be constructor not wish to build the Colpitts receiver, he may perhaps care to try the ultra-audion version shown in Fig. 2. This will be found to be particularly efficient on 10 and 20 meters as well; so it is quite worthy of attention. The aerial coupling is a special point to be noted; this method appears to give improved results. C6 may be a Hammarlund 16-mmf., with one plate removed.

The 5-Meter Transmitter

What is the best circuit? A rather difficult question to answer, since everybody has his own particular favorite; but the writer has found that the Hartley is not very efficient, either in theory or in practice. Good results can be obtained with the T-P.T-G, but the balanced Colpitts appears to be the ideal circuit, and this is depicted in Fig. 3. Upon examination, it will be seen that the grid and plate inductances together make up the tuning inductance; the direction of winding is such that the one coil is a continuation of the other, but the connections to each inductance must be arranged so that the high-potential ends are adjacent. Balance is obtained by adjusting the ratio of the capacities C1 and C2 for minimum feed current. This is equivalent to adjusting the tap on a Hartley transmitter. Do not omit the R.F.C.'s.

After adjusting the circuit the position of the node on the inductances can be found with a neon tube and the relative sizes of grid and plate coils adjusted

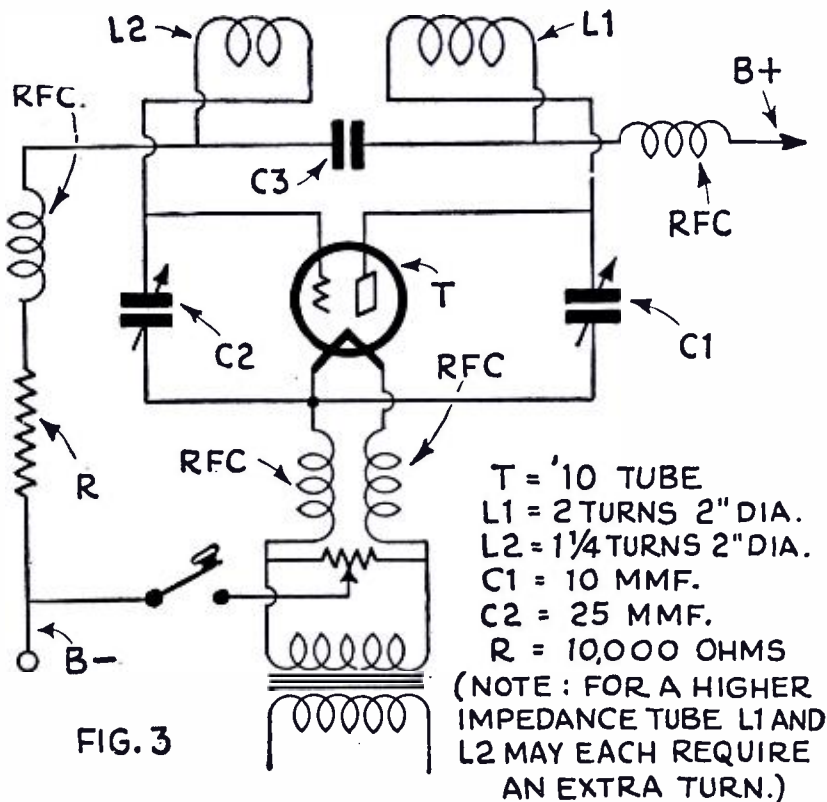

Fig. 3 — At left, shows a five meter, short wave transmitter of the balanced Colpitts type, utilizing a '10 tube.

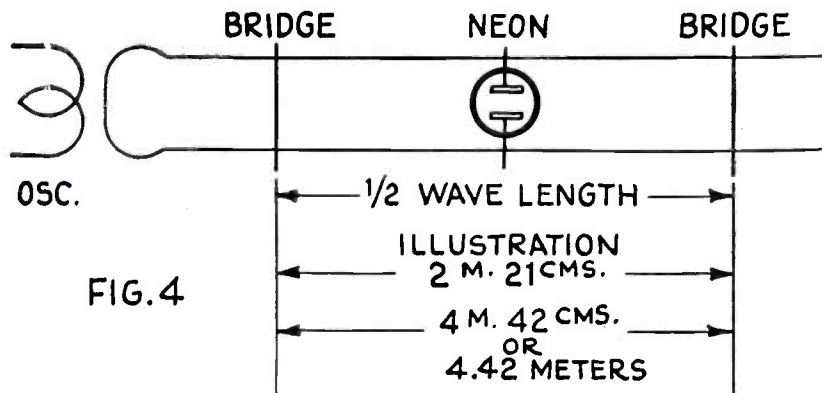

Fig. 4 — At left, shows arrangement used by the author for measuring ultra-high frequencies. Two copper wires are strung parallel and these wires are bridged by a neon tube and two “shunts.” The method of using this device is explained in the text.

accordingly, so that C3 is at the point of zero potential. There is not a simpler piece of transmitting apparatus than the ultra-audion for 5-meters but it rarely approaches the Colpitts in efficiency. In one illustration the writer's transmitter (described in the Feb.-March issue) is shown without a tube in position; the means of varying the capacity can plainly be seen. Another similar piece of apparatus is also shown with tube mounted. These photographs will show how a 5-meter transmitter should be made, more clearly than words.

In laying out a transmitter the following points are to be observed: mount tuning condensers as close as possible to the tube; take the leads to the inductances straight off the condensers; keep all R.F. leads as short as possible, and use bare copper wire; see that masses of metal, such as variable condensers and the plate of the tube, are not in the field of the inductance.

Adjust the transmitter as follows: Obtain a lamp (for a 10-watt transmitter a 7-watt automobile bulb may be used) and connect across it a loop of wire—3-inch diameter will do. Having adjusted the transmitter for minimum feed, approach the loop to the coil until the brightness of the lamp reaches maximum or until a small increase in brightness is offset by increase in feed current, and note the milliamps reading. Remove the lamp and increase the antenna coupling until the feed current reaches its previous value. From “The T & R Bulletin” (Nov., 1930) we find the relative efficiencies of different transmitting circuits to be as follows: Ultra-Audion 20% to 40%; T-P.T-G 35% to 45%; Colpitts 45% to 55%.

Measurement of High Frequency

And now for the means of measuring one's frequency accurately. Start up the transmitter; couple to oscillator a single-turn inductance, and lead two hard-drawn copper wires, parallel, to a distance of 24 feet. Pull them tight with two turnbuckles to prevent vibration. Bridge a neon tube with rigid leads across the wire (see Fig. 4), and move same slowly along wires with a long stick until it lights up. Leave it there. Bridge a stiff piece of copper wire across the parallel wires towards the oscillator, and move it slowly with the long stick towards the neon tube. The tube will be out but, at some point, it will light

up again. Select a second piece of wire and place it across the parallel wires at a point beyond the neon tube—which will again go out; move this wire slowly until the neon tube lights up again; it will now be observed that the tube is between two wire bridges or short-cir-

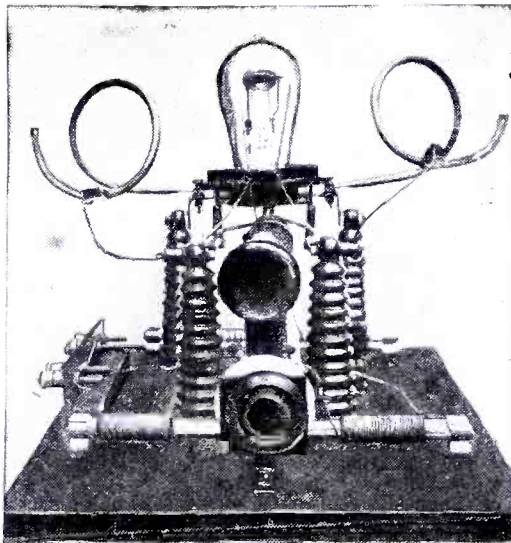

Another view of an ultra-short wave transmitter built by Mr. Somerset.

cuts, but lights up. It is lighting on the voltage point.

Each piece of wire across the two parallel wires represents the start and finish of the half-wave. Measure with a meter stick the distance between the two wire bridges and multiply it by two, because this is the half-wave.

Now calibrate a frequency meter (General Radio type 558-P) to this measurement; a home-made one will do if that specified is not available. Start to

Fig. 5—At the right shows method suggested for building a five meter “beam” antenna, useful for altering the angle or direction of propagation of a wave.

plot a graph. Change the tuning capacity on the oscillator slightly and measure the wave again; calibrate to this and plot another point—and so on until at least ten plotted points appear on the graph. Then draw a line through the dots, and this will be the calibration for the transmitter.

To make up a meter, take a 100-mmf. variable condenser and mount it on a small piece of bakelite (about 5 inches square) and bridge it with a single turn of heavy copper wire 3 inches in diameter. If the condenser is fitted with a good vernier dial it will make quite a good wavemeter in conjunction with the graph furnished by the measurements carried out as indicated. This wavemeter will serve also to calibrate the receiver.

Five-Meter Antennas

It is in the field of aerial design that a lot of useful research work can be done but, for starting up, practically any kind of transmitting aerial may be tried. Our old friend the “Zeppelin” with a single-turn untuned coupling coil will do admirably, if the transmitter can be situated at a current point in the system. (The writer would refer the reader to the A.R.R.L. Amateurs' Handbook for a full description of Zeppelin antennas.) There is just one thing to bear in mind should a Zeppelin be already in use for the 20-meter waveband, and that is: if the feeders cannot be altered, try tapping one feeder on to the plate coil and the other to the grid coil of the Colpitts transmitter.

If it is desired to use directional antennas, then either of the following may be tried (but the writer has found the second to give the stronger signals over a distance of 12 miles): the first is a vertical half-wavelength radiator with four reflectors in line, the center two being one-quarter-wavelength distant from the radiator. The second type was,

(Continued on page 66)

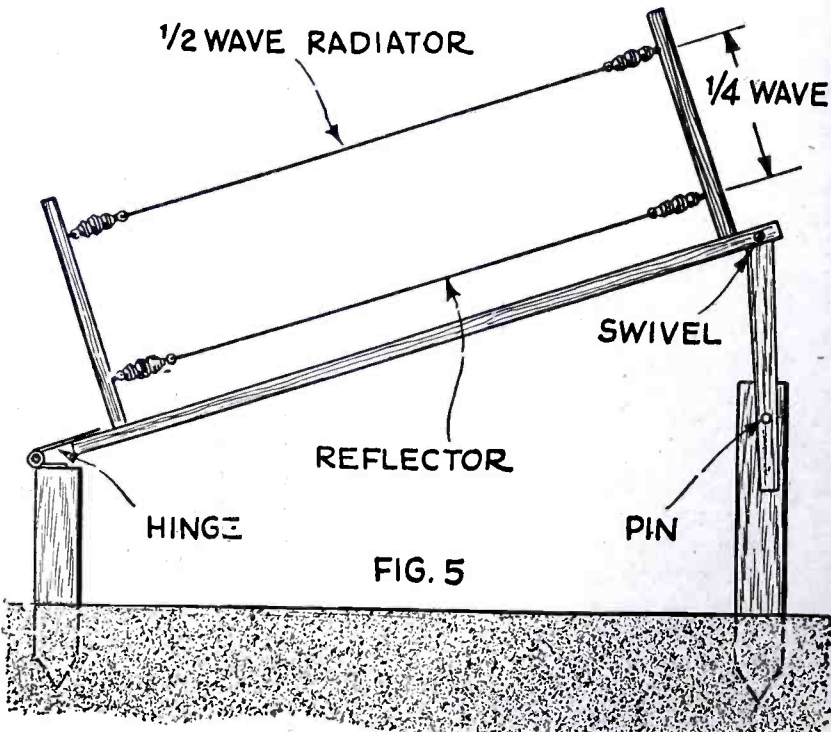

Short Waves Outwit the Oyster

By S. R. WINTERS

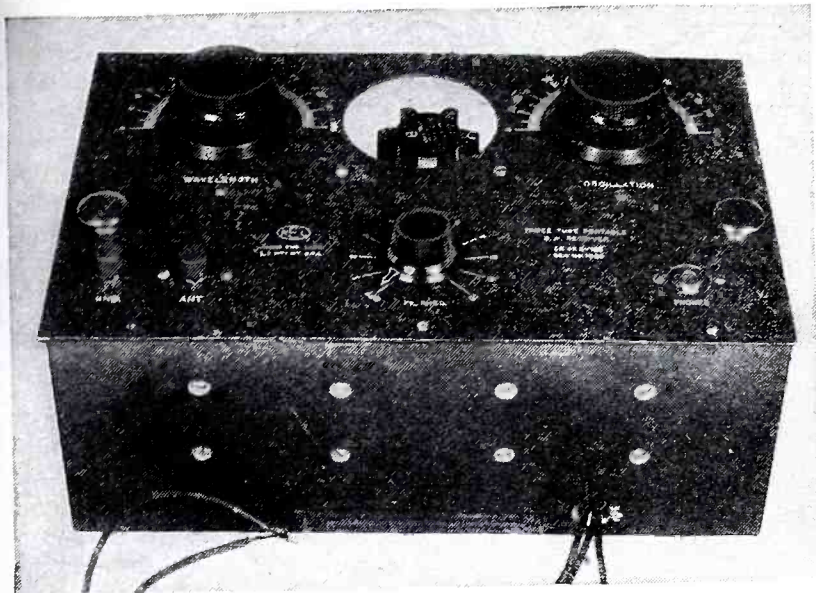

Short-wave receiver used in radio and sound surveying.

How Radio and Sound Waves Are Used to Survey or Locate a Given Spot Over Water

THE oyster, once indicted as an interference producer in radio-sound surveying on the coast of the Atlantic Ocean, is about to be outwitted. Or, accepting the less fantastic theory that the interference had its source in a 5-mile wire used in the off-shore charting operations, the induction noises are being surmounted. The Coast and Geodetic Survey of the United States Department of Commerce has, for several years employed a combination of radio and sound on the coast of the Pacific Ocean for surveying off-shore waters during fog or low visibility; but, when the same system was in-

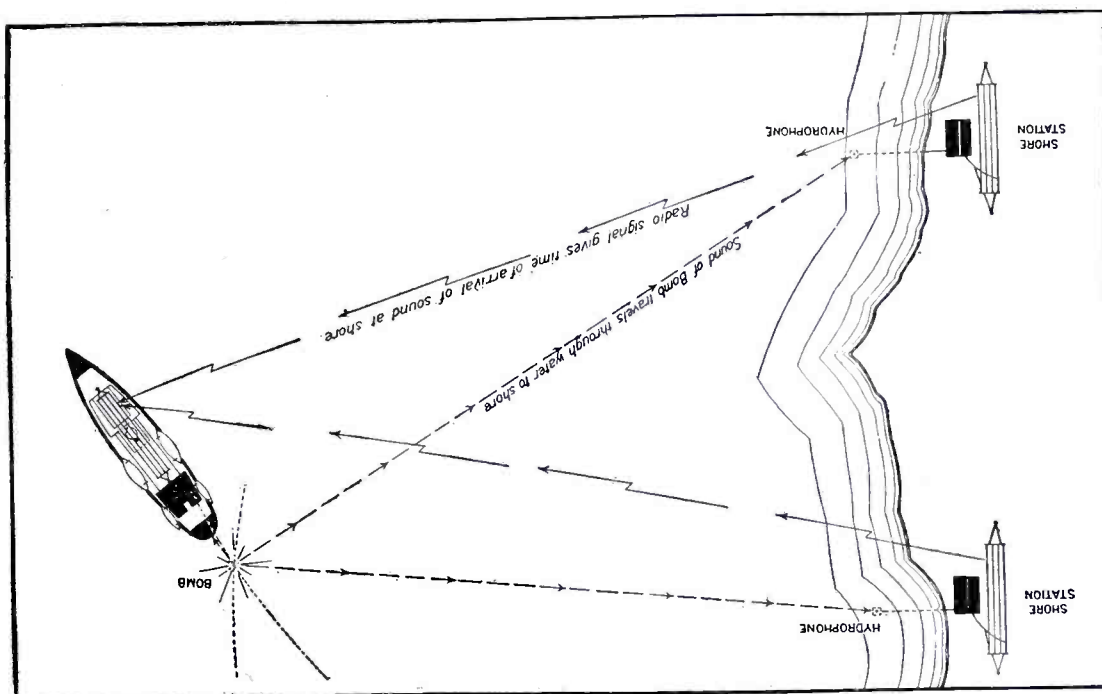

Above diagrams show paths of sound and radio signals used in surveying over water; the sounds from oysters were suggested as an interference factor by some experts.

Wiring diagram of the short-wave receiver used, appears below at left.

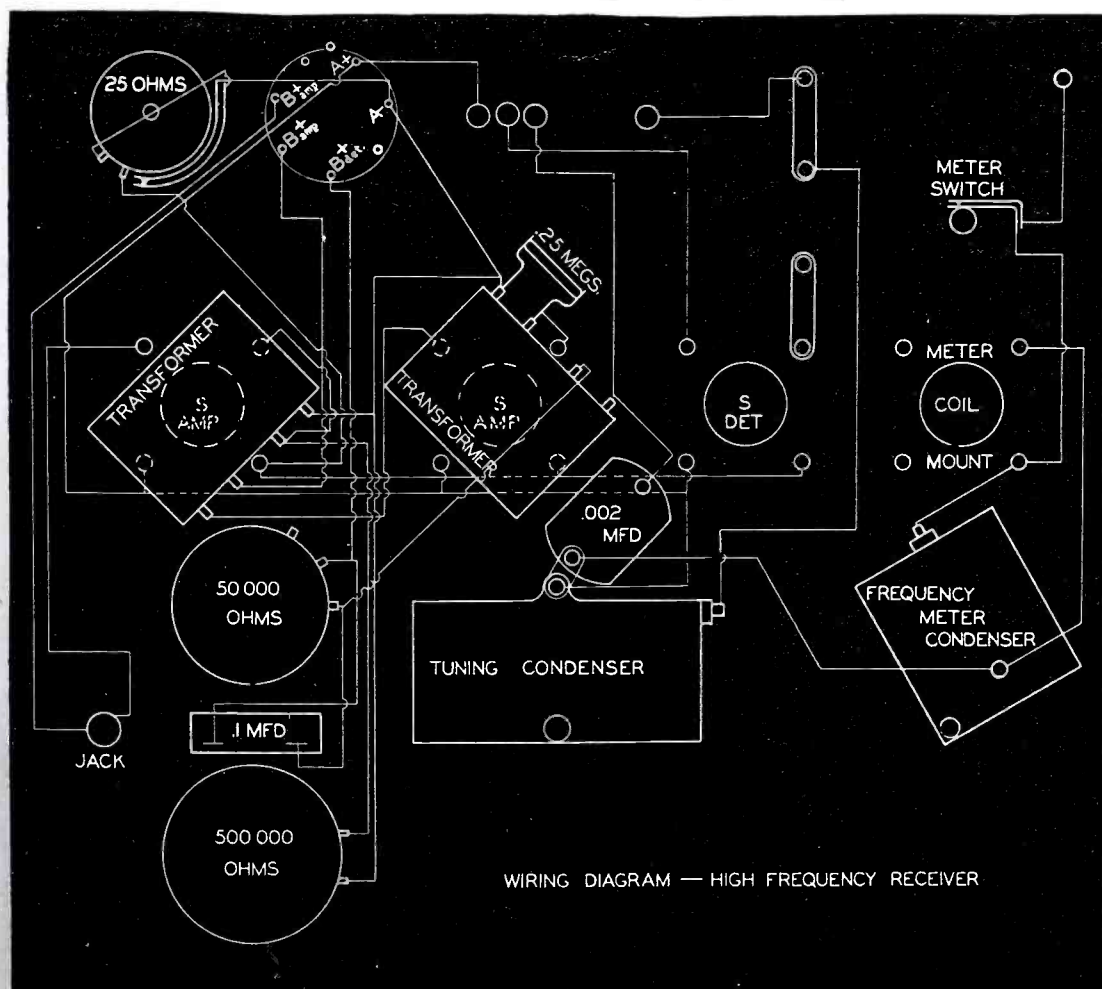

WIRING DIAGRAM — HIGH FREQUENCY RECEIVER

roduced on the coast of the Atlantic Ocean, strange noises—either the clicking of bivalves or induction interference—spoiled reception with the extremely sensitive sound and radio apparatus.

Difference in Speed of Radio and Sound Waves Utilized

Briefly, the principle underlying the radio-acoustic method of ranging is to utilize the difference between the speeds of radio and sound waves and, to take advantage of this, the surveying ship is equipped with wireless and acoustical instruments and similar installations are made at two shore stations. The shock of a bomb exploded on the surveying ship travels through water to the two shore stations and, upon its arrival, it trips a radio-telegraph key. The radio signal of the latter is received on ship-board immediately—thus denoting time of arrival of the bomb-exploded sound at the shore stations. Coast and Geo-

(Continued on page 60)

AROUND THE WORLD

WITH A 15-WATT TRANSMITTER

By A. BINNEWEG, JR.

HOW times have changed in amateur radio! Only a few years ago it required quite a little power, an exceptional antenna, the proper atmospheric conditions, a good receiver—and the “midnight oil”—to work across an ocean or across the continent. Few did it. Then, the man with the high-power outfit, and the tall

Complete constructional details of an “all-wave” transmitter and a short-wave receiver suitable also for broadcast reception.

Another important feature of this set is its flexibility. Since everything is in sight, and conveniently located, all kinds of adjustments to blocking condensers, gridleaks, antenna coupling, etc., can easily be performed without even changing a connection. Thus, the set can be adjusted for maximum efficiency—and DX!

The circuit of the transmitter is shown in Fig. 7; the receiver will be described last. All parts in the transmitter are mounted on small panels, which are screwed to a main chassis; by means of wooden “rails,” the whole chassis may be moved, to obtain the proper antenna coupling.

The transmitter's tuning capacities are double-spaced condensers which were initially of 43 plates, having a maximum setting of .001-mf. Every other plate is driven out with a small screwdriver; and the lock-nuts on the end plates are adjusted so that the remaining plates are spaced correctly. The final capacity is about .0002-mf.; and this spacing will withstand rather high voltages. The plug-in attachments are mounted on the condensers, one on the strip supporting the stator plates, and the other on the rear end-plate. Small holes are drilled for the purpose, when the condenser is double-spaced.

Construction of Inductances

The coils are wound of copper tubing, and the entire winding for all the coils is

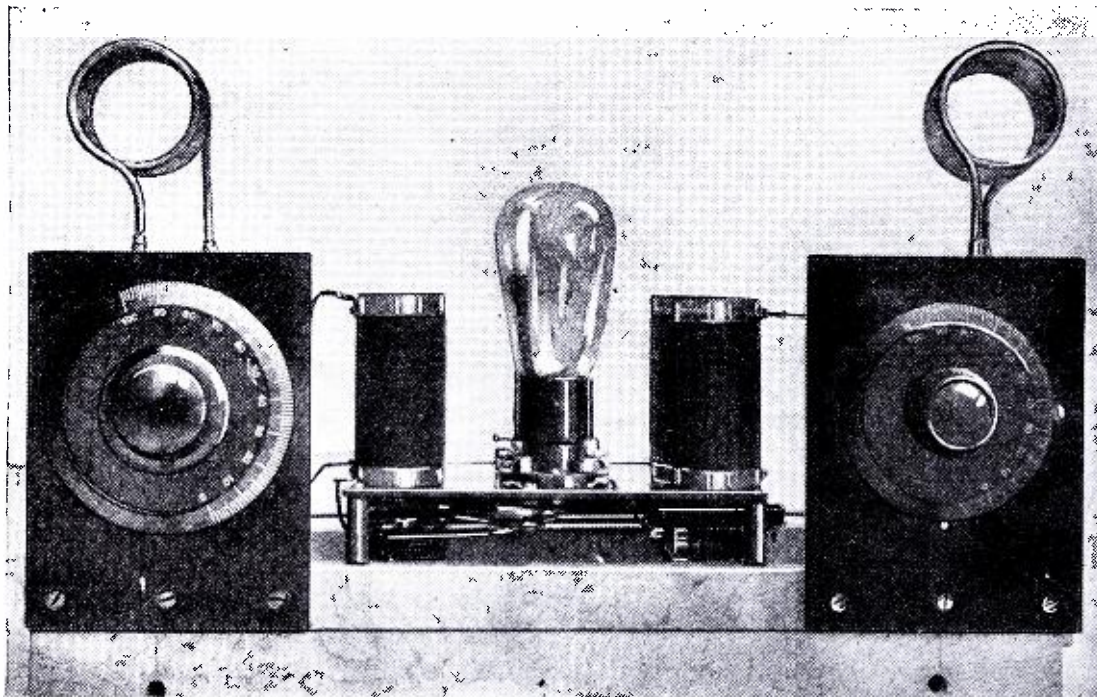

Front view of 15-watt short-wave transmitter.

antenna masts, occasionally did some DX of which he could talk; and of course, everybody believed him, whether it was true or not, because of the shiny panel and the long white poles, with hundreds of guys, and two huge cages in the flat-top (which blew down every now and then).

Then the short-waves came. It is difficult to locate a short-wave amateur station these days, because the antenna and counterpoise are only single wires, and there are no huge stand-off insulators. A low-power set works round the world in the daytime! The equipment is simple to build, the antenna too; the atmosphere doesn't have to be exactly right; the receiver has screen-grid tubes, although exceptional work is done without them; and no “midnight oil” is required, but! Exceptional DX! And all is at a comparatively low cost, so anyone can get in on it. A large amount of power is not necessary to reach the ends of the earth, if one operates at the particular hour, favoring a given locality. More sensitive receivers have made it possible to

secure even better results, with low power.

A Set to Show Your Friends

The set to be described is of the “open” construction which appeals to visiting radio friends. There are too many sets hidden away in cabinets where no one can see them. Amateurs, in particular, like to look at the “workings”—under the sub-panel and around the tubes. You've seen them, at radio expositions, stooping over an interesting set! A broadcast set all covered over with “cans” disgusts them.



End view of 15-watt transmitter showing double sliding wood base.

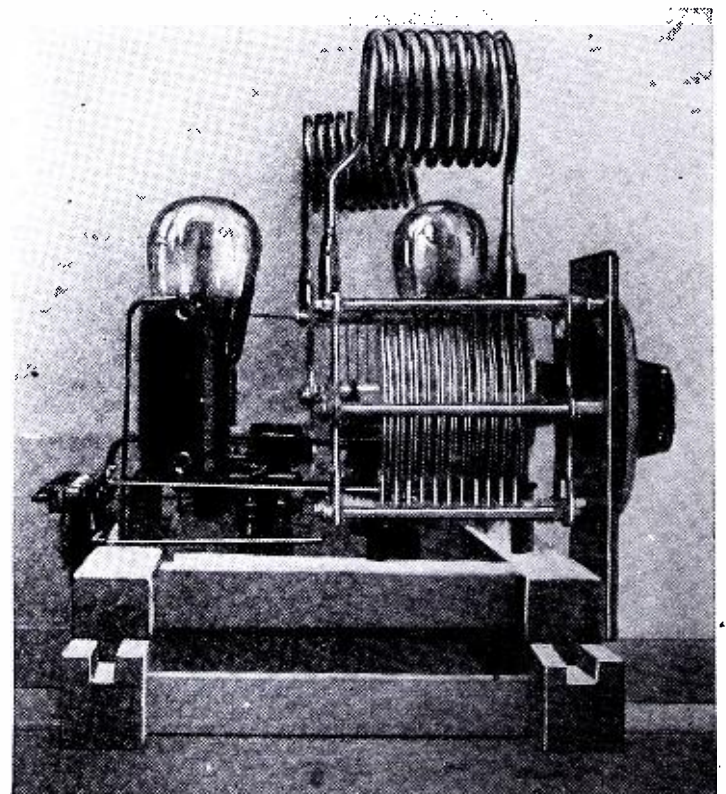

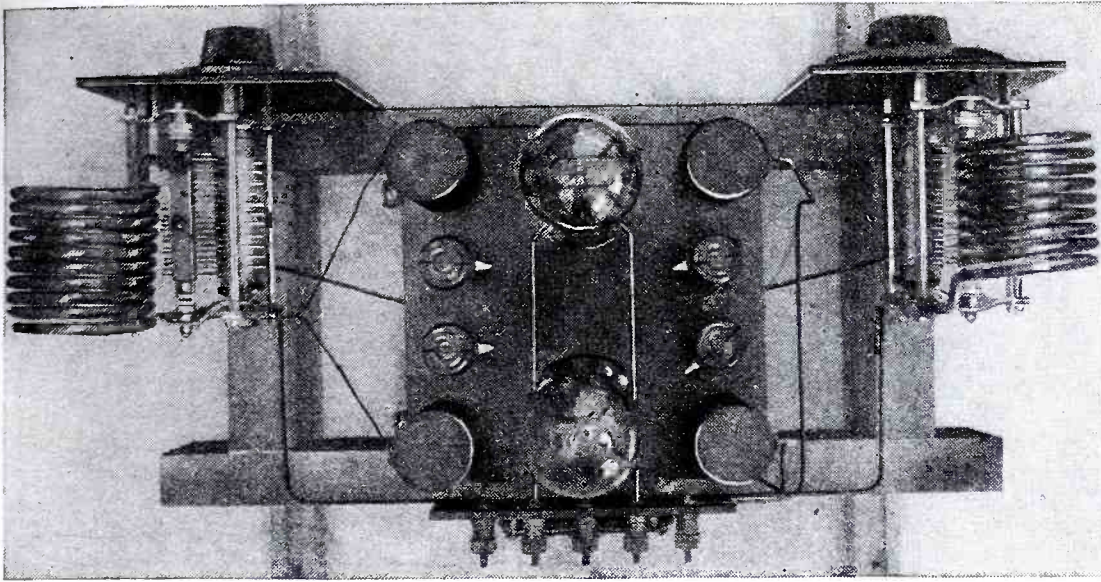

Top view of 15-watt transmitter.

done at one time. For 40 meters, 9 turns can be used in each coil; and at 20 meters, 3 or 4 turns is the correct value. Other coil sizes will be suggested later for various wavelengths available to amateurs. The antenna coil is made from the same winding and consists of 5 turns. Each coil is provided with a plug-in attachment, of which many types are available on the market. The blocking condensers are 50-mmf. "mid-gets."

The four chokes are wound on wooden forms, 1½ inches in diameter, and consist of about 100 turns of No. 26 wire. Small wood-screws and washers hold the ends of the wire firmly in place, and leads to the chokes are soldered to these screws. The chokes are mounted at the corners of the bakelite panel, and held by small screws. Holes are drilled in the bakelite for these screws, and the sockets and chokes are mounted on the panel before it is fitted into place on the chassis. The panel is supported about two inches above the chassis by lengths of fiber or metal tubing; long wood-screws fit through holes at the corner of the panel, passing through the tubing.

The larger the tuning condensers, the steadier the note, usually; but the capacities should not be too large, as the efficiency falls off rapidly. It is also desirable to have small grid and plate-stopping condensers to steady the wave. Small blocking condensers reduce the effect of the tube capacity, and the oscillating current passing through it. The theory of ordinary tube action requires a positive charge on the plate; and with A.C. on the plate, it is positive only half the time. It is usually easier to obtain steady outputs with D.C. on the plates. Ordinarily it is not desirable to operate a transmitter with A.C. plate source ("raw"), even in outlying locations where interference does not prohibit its use.

Choice of Power Supply

There is no mystery concerned with the fact that transmitters using D.C. "get out" considerably better. The low-frequency note given by a "raw" A.C.

source is more easily lost among interference, static and other background noises, besides giving a broad wave with the power distributed over a band of frequencies. A D.C. note, with a little ripple in it, is perhaps the best.

With high value grid resistors, the tubes may be operated with voltages as high as 1000 (for tubes like the '10 type) with no noticeable heating; although a lower voltage and about a 10,000-ohm leak will probably give better efficiency, over all, at 40 meters.

If the transmitter is operating efficiently, oscillations should not cease when the ordinary antenna is coupled closely, and tuned into resonance. It is not necessary to have a flashlamp in the wavemeter, or an antenna ammeter, if the plate D.C. milliammeter is of the proper range. Resonance is indicated by maximum plate current, and this indication may be made sensitive.

Large binding posts are provided for connections, and the filament by-pass condensers are mounted between the filament terminals here; the value of these condensers is not critical. The sockets should withstand the higher voltages used in transmission. The set is hooked up with No. 12 enameled wire. A saw-cut in the condenser knobs allows ad-

justment during operation, with an extension handle

If the set is operated in a self-rectifying circuit (see Fig. 1), a transformer having about 600 volts each side of the center-tap should be used. This arrangement is simple and economical; but if only one tube is to be used, some other type of rectifier is necessary, for full-wave supply.

A chemical rectifier gives good results. For about 40 milliamperes per tube, and 1000 volts, plates measuring ½ by 2 inches of immersed surface are required; 48 jars, connected "bridge" fashion, will do. The solution consists of distilled water with 1 oz. of baking soda to the gallon. "Forming" takes a few hours. When formed, the solution is "cloudy," but there will remain sufficient soda in solution for proper operation.

A word about adjustment will help. Before plugging in power, check the wiring. See that the plate-stopping condensers are not "shorted"; and follow the positive plate lead through, testing for filament connections. Run the filaments up to rated voltage. Leaving the key up, connect the plate voltage. Depress the key, and note the color of the plates and the plate current. When not oscillating, most of the power heats the plate. Set both condensers at about the same value. Oscillation is usually denoted by a sudden drop in plate current. It may be necessary to raise the key each time an adjustment is made.

Methods of Antenna Coupling

The simplest antenna and counterpoise is shown in Fig. 1. The 5-turn coupling coil is connected between the two, and these may proceed in any directions, as long as they are separated, and in the clear. A 23-plate receiving condenser is connected in series with the antenna, and the antenna-coil should be about two inches from the plate coil, for 2-inch coils.

One of the most important considerations, in any transmitter, is the method of obtaining the proper coupling between plate and antenna coils. There are still some amateurs who believe that there should be also some definite coupling be-

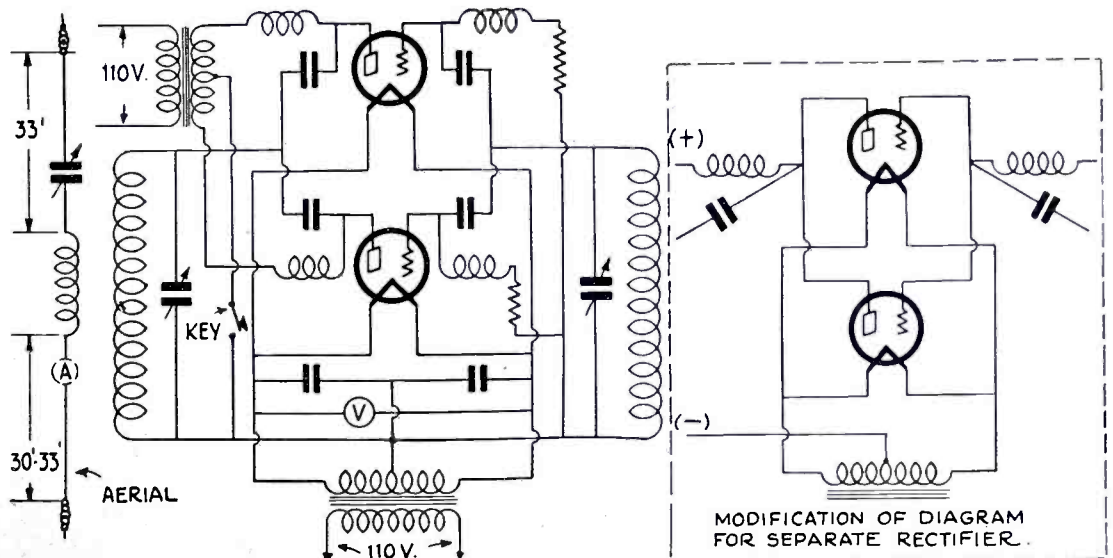
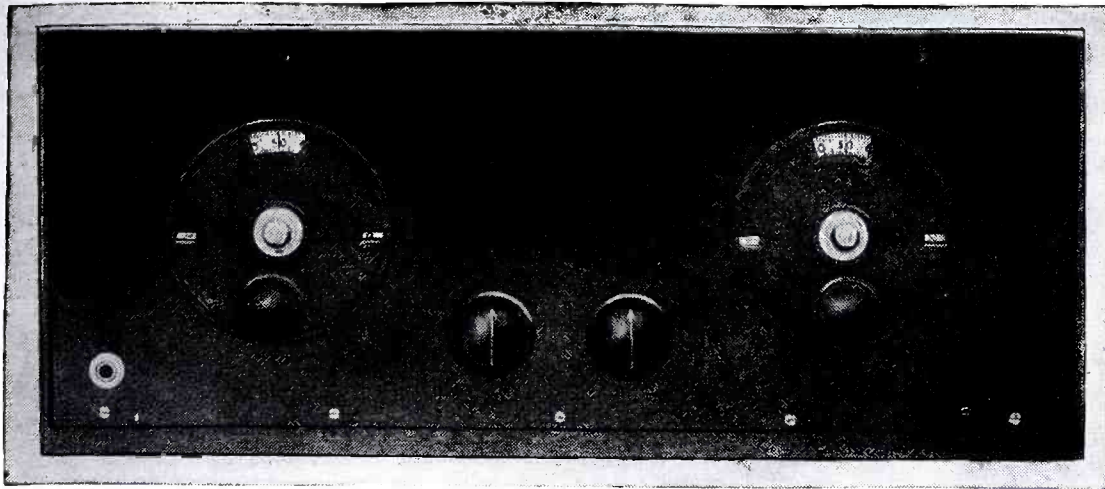

Fig. 1—Diagram of 15-watt short-wave transmitter.



Front view of short-wave receiver.

| Waveband | Coil Diameter | No. of Turns |
|----------|---------------|--------------|
| 80-meter | 2 3/4" | 10 |
| 40-meter | 2 1/2" | 5 |
| 20-meter | 2 1/4" | 3 |
| 10-meter | 2" | 2 |

For the 10-meter band, the necessary coil value will be influenced to some extent by the tubes used, and other particular circuit conditions and factors of construction. All of the above coil sizes are for coils of copper tubing.

Layout of Transmitter

The transmitter chassis is something quite extraordinary and will be described in detail. As may be seen in the illustrations, it is of open construction, so that everything can be easily adjusted and everything is also, in plain sight. The proper coupling between primary and antenna coils is important and is usually difficult to obtain; especially if the coils are mounted above the set and in the clear. It is better to arrange the set-up so that the plate coil can be adjusted, instead of the antenna coil, if this can be done without any changes within the set itself. The entire set is mounted on a light wooden frame (see photos and drawings, Figs. 2 and 3), to which the panel is attached by means of long wood-screws fitting through holes in the panel and then through pieces of fiber or metal tubing, thus supporting the panel above the frame. If the set is mounted in approximately the correct relation to the antenna coil at the start, there will be little difficulty in securing the proper antenna coupling. The only flexible leads are those supplying plate and filament power and, of course, a little bending of these is of no consequence; since, when final adjustments are once made, these leads can be wired in solidly.

Complete dimensions are given for construction of the chassis in Figs. 2 and 3. Measurements between parts are also given; so that this arrangement, which has proved both simple and flexible in practice, can be duplicated exactly by any constructor. It is a very efficient arrangement.

Although maple wood was used for the chassis illustrated, this may be difficult to secure in some localities, or some other good wood may already be available. Any good wood which can be worked easily

and which gives a good finish, can be used, of course. It is preferable to varnish or shellac the frames to improve appearances; it will then be much easier to convince the family that a good-looking set on a table in the home will not detract from the appearance of the room.

The values of midget condensers used for blocking will ordinarily have little effect on transmitter operation, beyond a certain minimum. To adjust the set to any desired frequency, one simply tunes both plate and grid condensers to about the same dial setting.

Quite a little expense can be eliminated by using a flashlight-lamp in series with the antenna, instead of the more expensive meters. A length of No. 14 copper wire across the lamp serves as a shunt; it will be necessary to experiment with the lamp and shunt to obtain the correct values. If a plate meter is used, resonance with the antenna is denoted by maximum plate current. Although it is a good idea to use meters, a set can be operated temporarily without them. It is, of course, important to operate the tubes at correct filament voltage; a meter for this adjustment can ordinarily be borrowed. Since this set was designed for operation from an adjustable A.C. filament source, no rheostat is shown; but one can be added if desired.

Receiver for All-Around Use

Although some amateurs employ an elaborate receiver, employing one or more stages of screen-grid amplification and often a "peaked" audio stage, these receivers are not adapted for short-wave broadcast reception; while they are often more expensive and, therefore, find their

greatest use only in the amateur bands. Many amateurs, however, listen to short-wave broadcast stations and so a receiver covering somewhat more kilocycles, and having a more or less "flat-response" audio amplifier is employed. Such a receiver is shown in the illustrations, the circuit being shown in Fig. 5. It will be noticed that sufficient space has been allowed, at one side of the baseboard, so that a stage of screen-grid R.F. amplification can be added later if desired.

It will be noticed that the throttle-condenser regeneration control has somewhat more capacity than found in some short-wave receivers. It is found that a large throttle-control causes somewhat less detuning of the main circuit and has the advantage that it is simpler to adjust; the set will hold its calibration somewhat better for given conditions of operation. Although a small "midget" condenser can be employed for the tuning condenser, one often has available a condenser with larger plates which can be used for this purpose. The throttle-control should be about .0001-mf. or larger; otherwise the size of tickler winding will become quite large and often very difficult to adjust so that the condenser will give proper control.

The relation of the parts in the set, and their distances apart, often have quite a little to do with the operation of a short-wave set. It is for this reason that a baseboard layout (Fig. 4) of this receiver is given. This arrangement has worked to perfection; so the builder can proceed and feel reasonably assured, if good parts are used, and the set is properly wired, that good results will be obtained at the start, as the outfit has been thoroughly tested beforehand. It is discouraging, to say the least, to connect up a set and have it refuse to perform. Short-wave sets are cheaper to build than ordinary broadcast receivers but they require more care in adjustment.

Choice of Parts Optional

Parts which are not of the proper size for broadcast work can be used, and these are obtained for a small sum, or from the junk box. The coils can be constructed, if desired, although many types of good plug-in coils can be obtained at a nominal cost. A R.F. ampli-

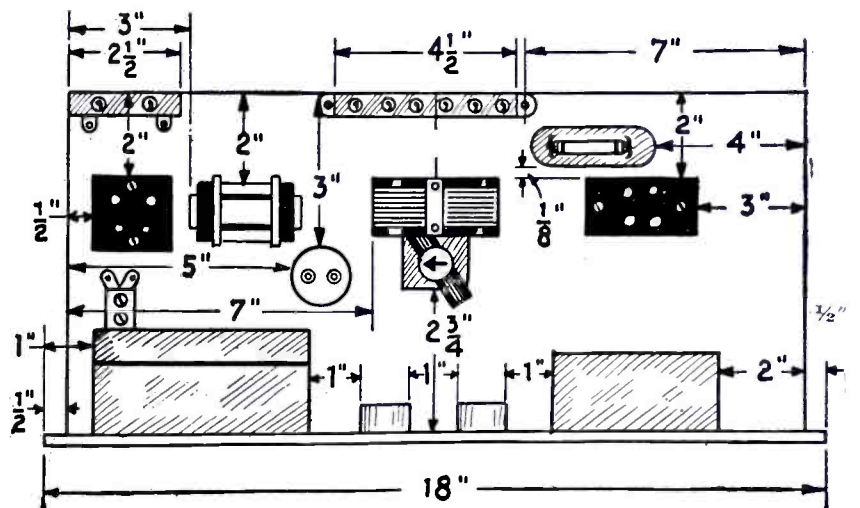
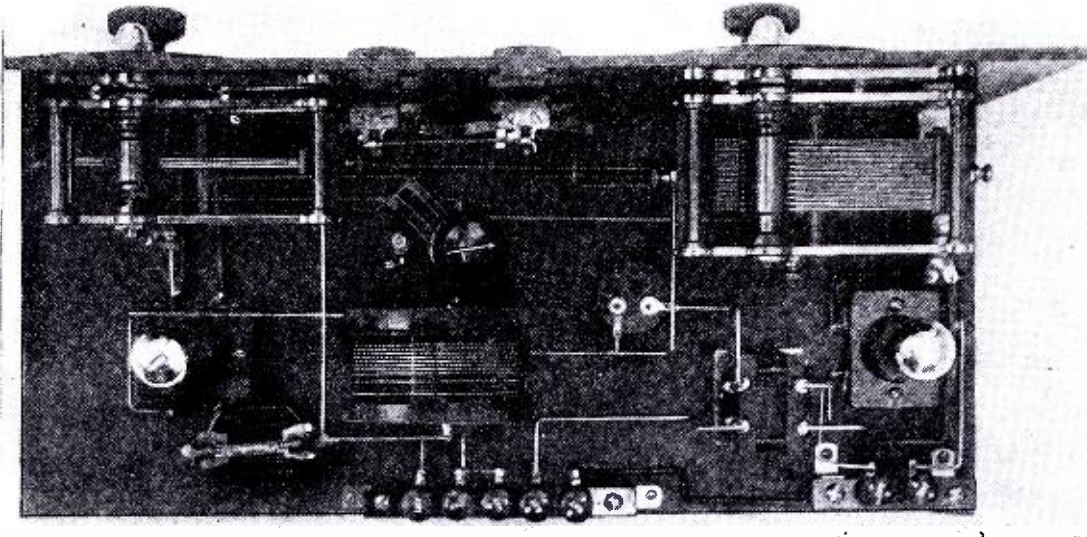

Fig. 4—Top view showing layout of apparatus in short-wave receiver.



should be .00025 mf. The choke can be constructed by winding 20 turns or so, of No. 36 wire on a ¼-inch dowel.

Although '99 tubes are used in this set, any standard tubes can be used. The plug-in coils available on the market are already provided with tickler windings; so little difficulty will be experienced in getting a set going if such coils are purchased.

For best results, the parts should be mounted with reasonable care. The arrangement used in this set is quite efficient; all dimensions are given, so that the set can be assembled easily. It is important to connect the rotors of both condensers to filament, and to mount the tickler-coil (if home-made coils are employed) at the filament-end of the secondary coil; otherwise anything might happen.

fier can be added to the set easily, as there is plenty of room; but good distance can be obtained with but the two tubes, and the R.F. amplifier may be added later.

The construction is almost self-evident from the illustrations. The panel is drilled for the condensers and rheostats; and the 'phone jack and filament-switch are mounted at opposite sides. The dimensions may be obtained from the list of parts, and the spacing is as shown in the front view of the completed set; no drilling template being necessary. Mount the equipment on the panel and baseboard, then wire the set, making the more important leads as short as possible. A few inches of extra wire makes little difference at about 40 meters; but at 20 meters it may cause difficulties, since the total inductance used is already small. It is the kilocycle range covered by one's tuning condenser, that really matters; a 3-plate condenser is large enough, and a larger size will make it more difficult to tune in broadcast stations.

The bakelite panel can be replaced by a wooden one if desired, if a good dry wood is used for the purpose; some woods can be boiled in paraffine to adapt them for this purpose.

Control of Operating Voltages

It is an advantage to use separate filament rheostats for the detector and amplifier tubes. Different tubes can be used and the proper setting for each tube can be obtained. Since proper oscillation and to some extent, the range over which this takes place, depend upon the filament setting, it is advisable to obtain the proper setting, which is usually at rated filament voltage. If a filament switch is used, it is possible to maintain the proper value without changing the rheostat each time. The '00-A tube requires about 5 minutes to settle down to proper operating condition; there is at first a tendency to "howl".

Top view of short-wave receiver.

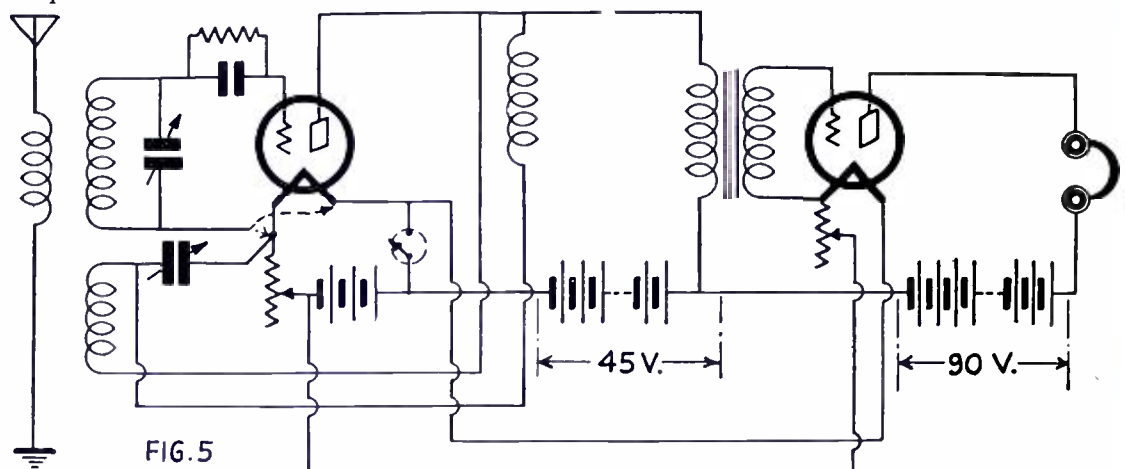

FIG. 5—Wiring diagram of short-wave receiver here described.

The secondary condenser consists of 3 plates and the throttle-condenser of about 13; although any size up to 23 plates can be used with good results. A vernier dial is used on the secondary condenser. The tuning condenser has a S.L.F. cut, and the other S.L.C.

The baseboard may be of any suitable wood; this may be covered with a piece of ordinary dark linoleum, on which the battery leads are run directly. The baseboard is one inch shorter than the panel, to fit the cabinet. The different types of cabinets are legion. Holes are drilled at the rear for the battery leads; if flexible leads are used, and the holes are sufficiently large, the panel can be easily withdrawn to change coils.

The post strips are supported by small angles. If the tube hums when oscillations start, try a different value of grid resistance. When using a long, outdoor antenna, either use a small series condenser, or keep the coupling loose, so the receiver will oscillate easily. As suggested in the wiring diagram, try the grid-return to the filament on both the positive and negative sides; some tubes work better on one side than on the other. The usual value of grid leak is about 5 megohms; the grid condenser

List of Parts for Transmitter

- 2 UX '10 power tubes
- 2 Bakelite UX sockets
- 2 .001 mfd. variable condensers—13-plate (for double spacing)
- 4 Variable "midgets" .00005 mfd.
- 2 Transmitting grid resistances (about 10,000 ohms each)
- 2 .002 mfd. Filament by-pass condensers
- 350 ft. No. 26 d.s.c. wire for chokes
- 2 ft. 1½-in. diameter wood for chokes
- 2 Dials
- 12 ft. 1¼ by 1 inch maple for chassis
- 2 pcs. bakelite, 4½ by 6 inches
- 1 pc. 2 by 6-inch bakelite for post strips
- 1 pc. 7½ by 7½-inch bakelite (all bakelite ⅜-inch stock)
- 25 ft. ¼-inch copper tubing for 40-meter coils only
- 10 ft. No. 12 enameled wire for wiring set
- 5 large binding posts
- Wood screws, machine screws and nuts, etc.

List of Parts for Receiver

- 2 Dials
- 2 30-ohm rheostats
- 1 Telephone jack
- 1 .00025 mfd. grid condenser—mica
- 2 UX sockets
- Detector tube, '99 or '00-A
- Amplifier tube, '99 or '01-A
- 1 r.f. choke coil
- 1 good audio transformer
- 1 set short-wave coils
- 1 3- or 5-plate tuning condenser
- 1 Throttle condenser, 13-plate (not critical)
- 7 Lettered binding posts
- 2 Post strips
- 1 7 by 18 panel; bakelite, hard rubber, or even wood
- Wood screws, brass angles, machine screws and nuts, etc.



The SUPERIOR SHORT WAVE RECEIVER USED AT G2DT

THE receiver, seen in the photograph of experimental station G2DT, is designed for amateur code and broadcast phone reception. From the diagram, it will be seen that it employs a screen-grid T.R.F. stage, followed by a screen-grid detector. Out of fairness, I must state that the screen-grid tubes used here are "Mazda

By E. T. SOMERSET,
Owner and Operator

This article gives the S-W "ham" an idea of what is being used in England for the reception of long distance signals.

when the load resistance is equal to the plate resistance of the tube. This, however, is impracticable; as it would mean a plate resistor of the order of one megohm and would cause an appalling drop in the voltage applied to the plate of the tube. It is necessary, therefore, to strike a balance and, if 300 volts "B" is available, it is usual to use a plate resistor of the value of 250,000 ohms. If the available voltage is only 180, then it behooves us to use a resistor of 100,000 ohms, to obtain efficiency. This value is shown in the diagram at R4.

It will be observed that a variable resistor is shown at R2, and with good reason. The screen-grid tube is, in reality, extremely critical as to the screen-grid voltage, when functioning as a detector; and this control, when properly regulated, will show a reading of the order 0.8= to 1.0= milliamperes upon the meter in the plate circuit. Such a reading will be indicative of correct functioning.

The coil forms used are "R.E.L.,"

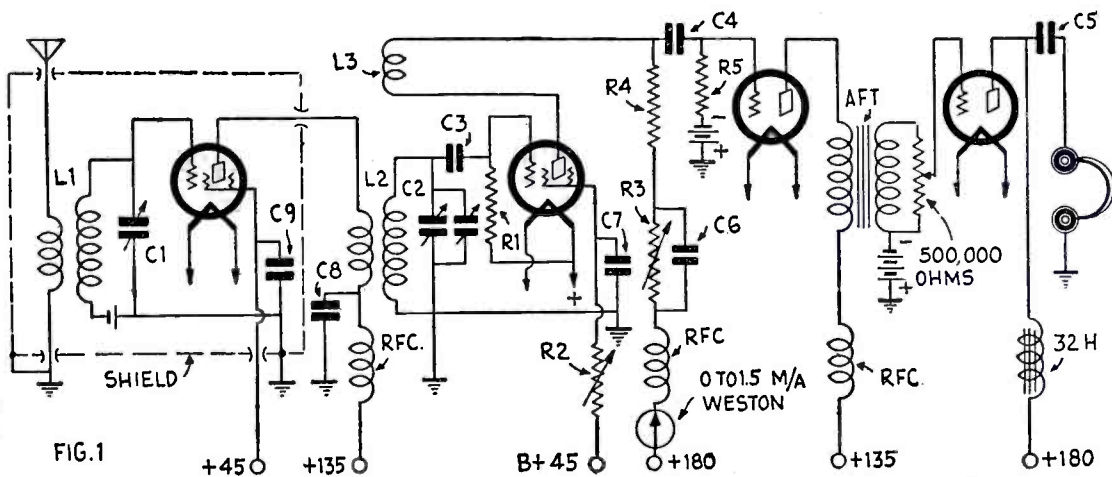

SG-215" which are identical in micromhos with the American '24; but their grid-to-plate capacity is five times less and this is, of course, an enormous advantage. However, there is no reason to suppose that the new '32 will not make an admirable substitute, in spite of its 0.02-mmf. grid-to-plate capacity.

In using the screen-grid tube as a detector, it must be remembered that the voltage amplification depends almost entirely upon the load impedance; hence the overall frequency-characteristic of tube and load is very different from what would be obtained from a three-element tube, or "triode," having low plate impedance.

One way of explaining this difference between the screen-grid tube and the ordinary "triode" is to say that, in the circuit of the latter, where the load impedance is usually higher than the plate resistance, the current through the load is determined more by the load impedance than by the plate resistance. In the screen-grid circuit, the plate resistance is almost invariably higher than the load impedance; and the current is determined mostly by the plate resistance instead of the load impedance.

Wiring diagram of G2DT short wave receiver, employing one shield grid R.F. stage ahead of regenerative detector, feeding into a resistance-coupled A.F. stage and then into a second transformer-coupled stage.

This diagram shows method of adding another R.F. untuned stage to G2DT's receiver.

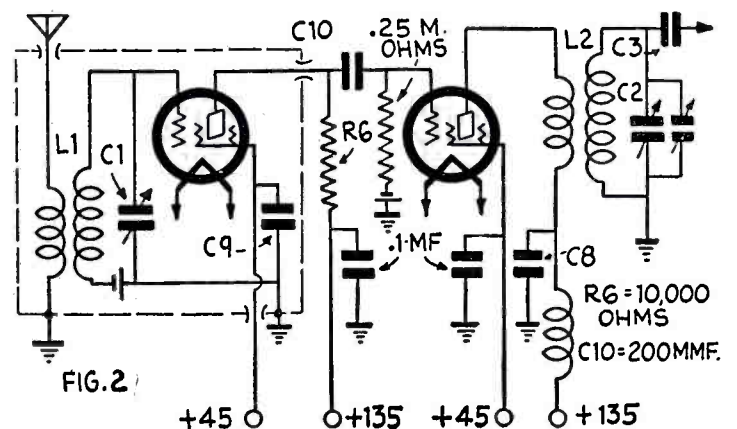

The maximum output from the screen-grid tube, used as a detector, is obtained

whose average diameter is 1 3/4 inches; they are of truly skeleton construction and, if wound with 27/42 D.S.C. Litzen-draht wire, will be found to be extremely efficient. For C1 and the tank capacity C2, the Hammarlund "MC/23" condensers can be used as very little surplus metal appears in their construction. The vernier, which is wired in parallel with C2, is an "R.E.L." adjustable, but Cardwell's new type will serve just as well.

When the set is used as an amateur-band receiver, the tank C2 is set by means of a wavemeter in the desired band; and the stator of the vernier is adjusted at such a distance from the rotor that full dial-spread is obtained. When it is desired to listen to short-wave broadcasting, then the tuning is done on C2 and the vernier is used for an accurate setting of resonance.

INDUCTANCE DATA TURNS

| | L1 | | L2 | | L3 |
|-----------------|-------------|-------------|-------------|-------------|----|
| 3,500-Kc. | Prim: 9 | Secy: 15 | Prim: 9 | Secy: 15 | 6 |
| 7,000-Kc. | Prim: 4 1/2 | Secy: 7 | Prim: 4 1/2 | Secy: 7 | 6 |
| 14,000-Kc. | Prim: 2 3/4 | Secy: 3 1/2 | Prim: 2 3/4 | Secy: 3 1/2 | 5 |
| 28,000-Kc. | Prim: 1 | Secy: 1 3/4 | Prim: 1 | Secy: 1 3/4 | 5 |

SPACING BETWEEN TURNS

| | L1 | | L2 | | L3 |
|-----------------|-------------|-------------|-------------|------------|-------|
| 3,500-Kc. | Prim: 3/32" | Secy: 3/32" | Prim: 1/8" | Secy: 3/8" | 1/32" |
| 7,000-Kc. | Prim: 1/16" | Secy: 1/16" | Prim: 1/16" | Secy: 1/8" | 1/32" |
| 14,000-Kc. | Prim: 1/8" | Secy: 1/4" | Prim: 1/8" | Secy: 1/4" | 1/32" |
| 28,000-Kc. | Prim: 1/8" | Secy: 1/8" | Prim: 1/8" | Secy: 1/8" | 1/8" |

1/4" gap allowed between WINDINGS
ALL WOUND ON R.E.L. SKELETON FORMS

(Continued on page 71)

Mercury Vapor Rectifiers

"A MAJOR RADIO ADVANCE"

By C. H. W. NASON

IT seems to be one of the faults of each new science that the work of mountebanks and clowns should receive the utmost of public acclaim, while the true advances go unheralded. It is true that, so long as the "inner fold" realizes the worth of a new development, the commercial advance of the art will be unimpeded by this condition—it is we of the "outer circle"—the amateurs—who suffer.

The Greatest Radio Advance

A great British engineer, visiting this country to study the commercial ad-

A famous British engineer visiting this country recently, stated that in his opinion the greatest radio advance was the development of the Hot Cathode, Mercury Arc Rectifier tube! Here is some data on how to use them.

a measure the extreme advance which has taken place in rectifier tube design.

amateur needs, and is cited merely as practical evidence of what these new tubes can do.

There are, however, two other tubes in the family which fall under the heading of *amateur equipment*; although the smaller of the two will fulfill all normal requirements. Their specifications follow:

These two tubes operate at the same voltage but have different power ratings, fitting them for differing services. For example, with a transmitter employing two type '52 tubes (requiring a total of 0.2-ampere at 3,000 volts) the 566 would be chosen. If, on the other hand, we desired to supply voltage for a multi-tube transmitter with modulation equipment, the total plate current would demand the use of the 572.

Meaning of "Inverse Volts"

The voltage rating in the table above makes reference to a factor heretofore unnoticed: that is, the "Maximum Peak Inverse Volts." This refers, not to the voltage of the power supply output, but to the maximum voltage which can appear across the tube during the reverse half-cycle in a full-wave system, when the tube in the opposite branch of the circuit is rectifying. This factor is the *peak* (not the R.M.S.) voltage of the total transformer secondary winding, minus the drop through the tube and its filament circuit. The reason for the high efficiency of these tubes rests in the

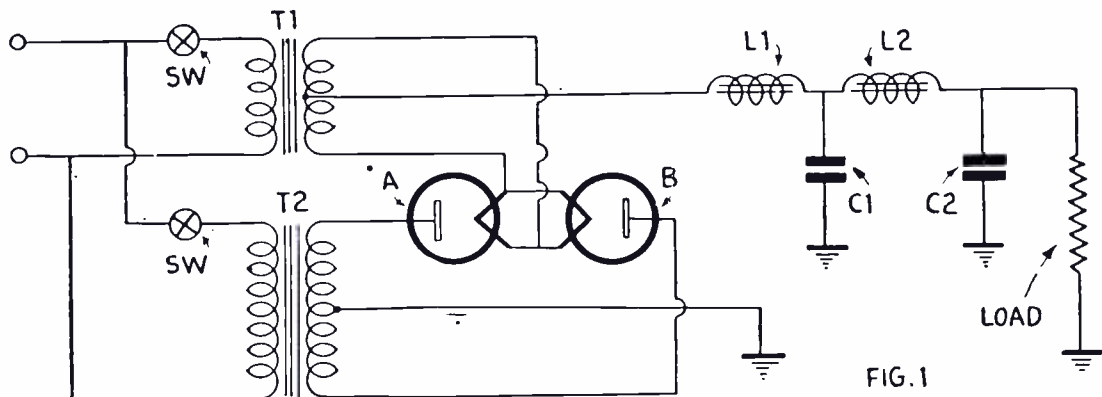

Fig. 1—Illustrates rectifier circuit employing two of the new Hot Cathode, Mercury Arc rectifier tubes at A and B. Here only one-half of the voltage of the power transformer is available at any one instance.

vances in radio communications, when asked what new development most impressed him, replied, "The Hot Cathode Mercury Arc Rectifier"! The writer concurs heartily in this opinion, and it is with no little faith in the value of this device to his fellow amateurs that he passes on this agglomeration of first-hand information and hearsay.

Heat—when viewed in connection with the plumbing art—represents an accomplishment—a gain. When seen from the viewpoint of the radio engineer, it represents a loss and a constant source of trial and tribulation. The '80 rectifier tube handles, usually, a power in the neighborhood of 50 watts; the heat developed by the tube under normal operating conditions is sufficiently great to require special consideration as to ventilation. The filament or "cathode" power consumption is 10 watts which, of course, contributes to the heating effect in a small measure.

Let us now consider a rectifier tube capable of handling a power of 75,000 watts, with its elements in the '04A 250-watt tube envelope (5¼ by 14¾ inches overall) and with a filament drawing twenty amperes at five volts (100 watts). This tube runs at a safe temperature, despite its capabilities, and illustrates in

The tube described above is the DeForest 569 hot-cathode mercury arc rectifier. It is, of course, outside the demands of all

| Type | Filament Volts | Filament Amps. | Max. Inverse Peak Volts | Max. Peak Plate Curr. | Base | Size |
|------|----------------|----------------|-------------------------|-----------------------|------------|-----------------|
| 566 | 2.5 | 5 | 7500 | 0.60 | UX | 2 5/8" x 6 3/8" |
| 572 | 5. | 10 | 7500 | 2.5 | 50 w. Std. | 2 1/8" x 7 1/8" |

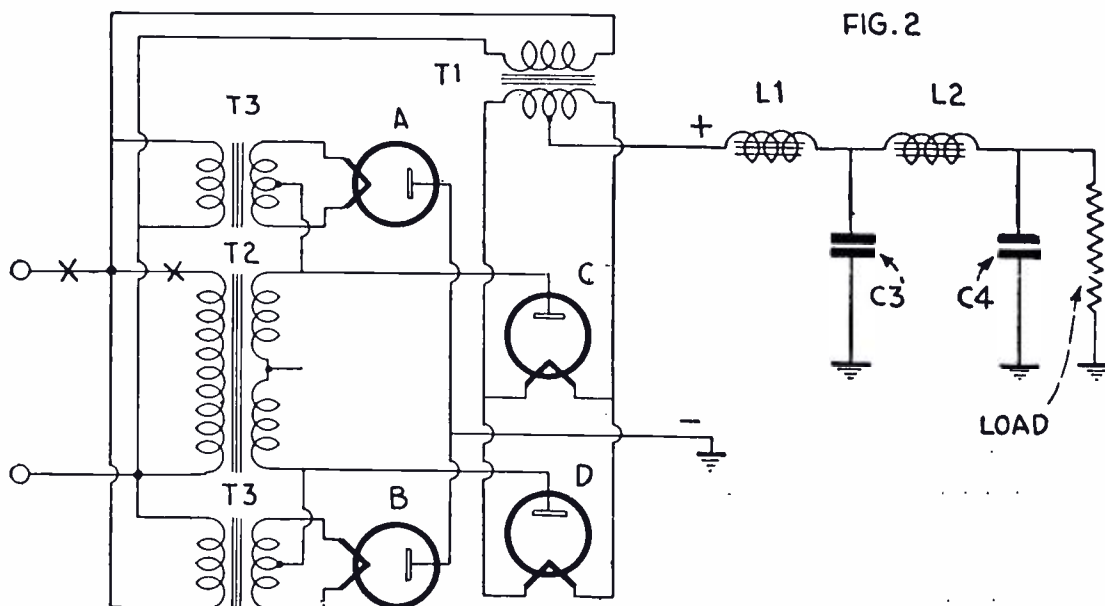

Fig. 2—Shows the author's circuit arrangement for a voltage-doubling system, which employs four rectifier tubes. The full transformer voltage is available at all times.

small resistance within the tube itself. The losses are equivalent to the usual I^2R , where I is the current through the tube and R the internal resistance. This internal resistance in the 566 is so small that little energy is dissipated in heat and the drop through the tube and filament circuit is not in excess of 15 volts. We may therefore neglect this internal drop and assume that the maximum peak inverse voltage across the tube is 1.4 times the R.M.S. voltage available at the outer terminals of the secondary. This allows us to employ a total secondary voltage slightly in excess of five thousand volts in a standard full-wave circuit—2,500 volts on each side of center tap. Because of the low drop through the tube proper, the regulation of the system is fairly good; the variation in output voltage with varying load current being limited to the IR drop in the filter reactors and in the transformer winding.

If the full value of this improvement in the regulation is to be obtained, the filter reactors and the power transformer must be designed generously and must, of course, be insulated against breakdown between windings at the high voltages involved. This property of the tubes, together with the low losses, constitutes the superiority of the device over all preceding systems. It is now possible to produce an intermediately high voltage supply, with better regulation characteristics than those obtainable with a motor-generator unit, at reduced initial cost and at greatly reduced operating costs.

How to Use the New Rectifiers

In the writer's opinion, the amateur is not half so interested in the theory of a new device, as in the means of its adaptation to his particular problems. We will not therefore deal at length with the theory of rectifier circuits as a whole, but with actual systems employing these tubes and with the safety measures necessary.

It will be noted that each system includes filament transformers separate from the plate transformers. While these tubes have a low internal drop at operating temperatures, the drop is extremely high during the warming-up period. If the plate voltage were to be applied during the warming-up period, certain destruction of the tubes through excess heating and possible destruction

of the other apparatus would result. For this reason, the filament and plate-supply systems have separate power control means; and *the filament current should be on for at least 45 seconds, before the plate supply is closed.* The temptation is always strong to see what will happen if these instructions are not followed. If you are more interested in pyrotechnics than in radio, this is a good idea—if not, it will be best to take the writer's word for it.

New Relay Useful for Controlling Plate Circuit

While separate power-control switches will solve this problem, the amateur with an artist's sense of the beautiful will be intrigued by the new Ward-Leonard *Self Re-cycling Time Delay Relay*. This device will automatically connect the plate supply system at any time within 60 seconds after the closing of the main power-control switch.

Because of the limitations of the tubes, it is not possible, with the normal full-wave circuit, to obtain an output voltage much in excess of 2,500 D.C. If full protection of the tubes and other equipment from surges is desired, an even lower output is to be recommended, with the use of an inductive input to the filter system. The use of the condenser input allows a higher terminal voltage at the filter input, but reduces the current capacity of the system. It is possible, with mathematical formulas, to calculate these factors to a marked degree of accuracy; and those of a technical turn of mind may discover these in the references following. We will concern ourselves with the actual circuits and apparatus rather than with theoretical considerations.

Voltage-Doubling

Where it is desired to obtain a higher output than is possible with the usual circuits, the *voltage-doubling* principle may be employed. In these systems the full transformer voltage is available at all times, rather than that of one section.

In the rectifying circuit shown in Fig. 1, the usual full-wave rectifying system is employed. During the first half-cycle of each A.C. wave, the current path is through the tube "a" and the load, back to the transformer center tap. During the second half-cycle, the flow is in the

same sense, through the tube "b." Only one-half the voltage of the power transformer is available at any instant.

The *voltage-doubling* system employs four tubes, connected as shown in Fig. 2. The current flow through the system during the first half-cycle is through the tube "c," the load, and back through "b"; its path during the second half-cycle is through "d," the load, and "a." The full transformer voltage is available at all times, with no increase over the conditions obtaining in Fig. 1, as to the inverse peak voltage across each tube. In all the full-wave systems, the current through each tube is flowing during one-half cycle only, and is approximately one-half the load current.

The legends of the two figures are interpretable from the table following:

List of Apparatus

- a, b, c, d, DeForest 566 hot-cathode mercury-arc rectifier tubes;
 T₁, Amertran H 66-A heater transformer;
 T₂, Amertran P 4656 plate supply transformer;
 T₃, Amertran H 4648 heater transformer;
 L₁, Amertran 4725 filter reactor;
 L₂, Amertran 557A filter reactor;
 C₁, Aerovox 1503 1500-volt condenser (2-1 mf., units);
 C₂, Aerovox 1503 1500-volt condenser (4-1 mf., units);
 C₃, Aerovox 2503 2500-volt condenser (2-1 mf., units);
 C₄, Aerovox 2503 2500 volt condenser (4-1 mf., units).

The first system is capable of an output of 1200 volts at 175 milliamperes. With the voltage-doubling system, the voltage and current values are double these ratings. It should be understood that the writer has specified here standard apparatus of a generally available character. Where higher voltages than those specified are desired, the plate transformer's secondary voltage must be increased accordingly. The heater transformers are satisfactory at much higher voltages, and need not be changed. The manufacturers whose equipment is specified above will be glad to furnish quotations on special equipment.

Bibliography

- O. W. Pike—*QST*, Feb., 1930.
 R. W. Armstrong—*I.R.E. Proc.*, Jan. 1931.

An Efficient Push-Pull C.W. Transmitter and Power Supply

The accompanying illustrations show an interesting and very efficient design of Push-Pull C.W. Transmitter and Power Supply. This transmitter was designed by Mr. George Granmer, Assistant Technical Editor of *Q.S.T.* The transmitter (right) may be built from radio receiver parts, the constructor having to wind special inductances which are composed of $\frac{1}{4}$ inch copper tubing. The power supply illustrated at left, is of the well-known National make, and the parts used in building the push-pull transmitter are also of the National make.

This transmitter, according to its designer, has great "reaching" possibilities, the transmitter requiring two '45 type tubes, in push-pull, with about 350 volts D.C. on the plates. More about this transmitter later.

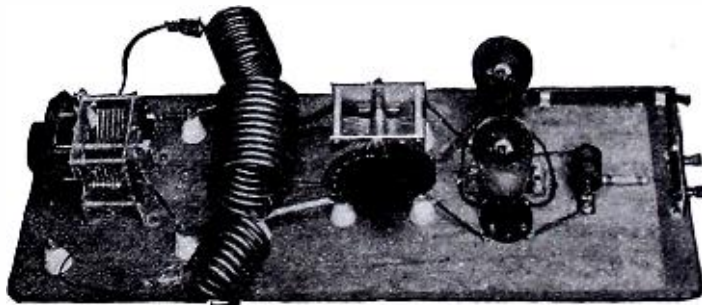
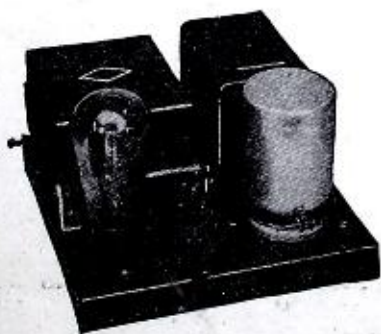

De Forest Short Wave Receiver

One of the newest and extremely compact, short-wave receiving sets, suitable for use on aircraft, motor boats, etc. This receiver measures only 5" x 6" x 9". It uses plug-in coils and has four tubes.

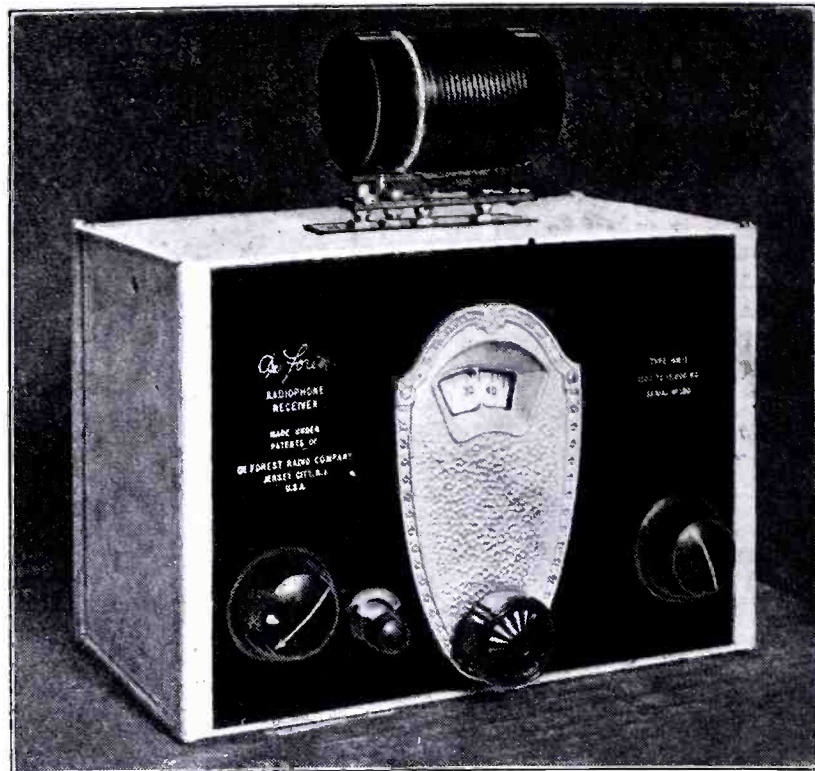

Appearance of the new DeForest Short-Wave Receiver, which is extremely compact, although it has four tubes, including two stages of audio.

A SHORT - WAVE receiver, said to be as efficient as any and with the added virtues of extreme portability and compactness, has been announced by engineers of the De Forest Radio Company. It is said to be particularly applicable to the receipt of amateur and short wave broadcasting, where a small set is desired. The precision with which this instrument has been designed is evi-

denced in the fact that except for the plug-in tuning coil, which is located on the top of the case, the entire receiver, including four vacuum tubes, is enclosed in a case measuring only 5 x 6 x 9 inches.

The circuit design of the new receiver is by no means revolutionary, the outstanding advantages being the simplicity and economy of space effected without sacrificing performance. The circuit in-

cludes one stage of aperiodic radio frequency, using the screen-grid tube, a grid leak and grid condenser detector employing a 412A tube, and a two-stage transformer-coupled audio amplifier employing 401A and 412A tubes. A separate C bias lead is included so that any other type of output tube may be used without necessitating changes in the wiring circuit of the receiver. The entire assembly, including tubes, coils and battery cable, weighs 7½ pounds.

Plug-in Coils Used

The standard production model of the new receiver includes four plug-in coils with a tuning range of 14 to 195 meters. Of course the ambitious amateur may wind up other coils to cover higher or lower wavelength to suit his individual requirements and desires. These four coils, with their accompanying regenerative tickler coils, are wound on thin bakelite tubing provided with four pin-jack prongs. The three lowest wavelength coils are made of No. 18 enameled wire and the largest of silk covered No. 28 wire. The tickler coils are all of No. 28 silk-covered wire.

The unusually small dimensions of the receiver are made possible by the ingenious mounting assembly, in the form of bakelite sub-panel, located three-fourths of an inch below the top of the cabinet.

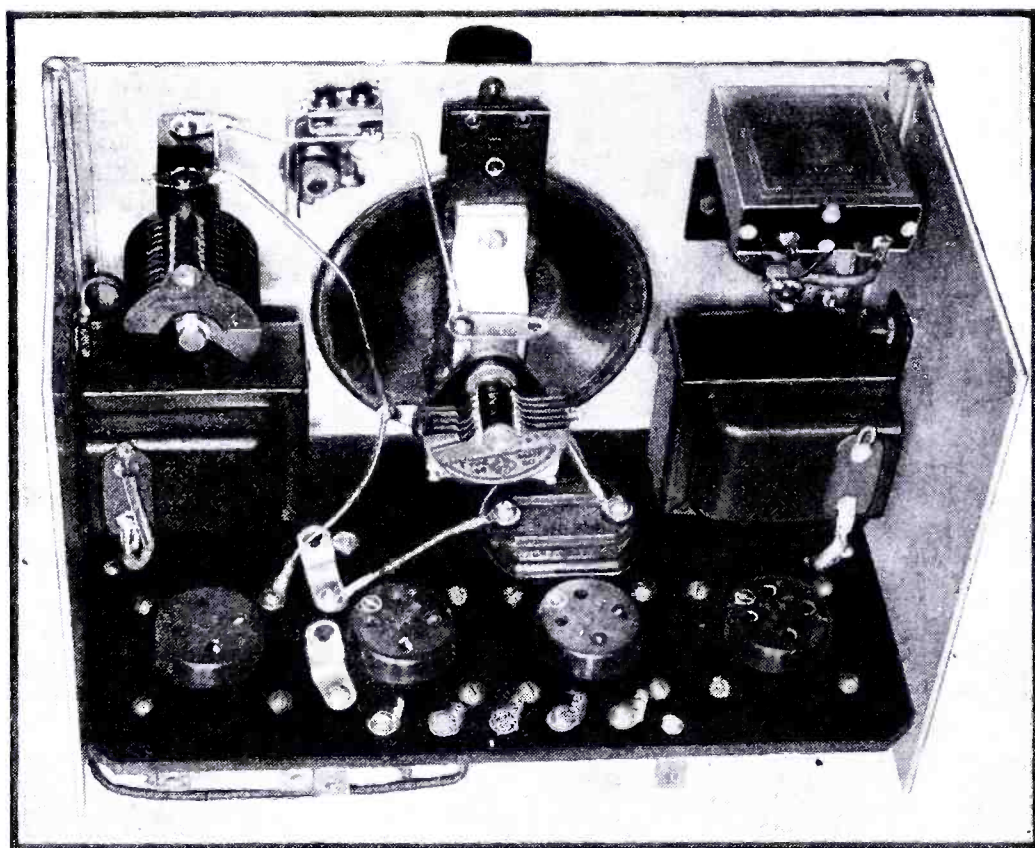

Rear view of DeForest, 4-tube, short-wave receiver with part of metal casing removed.

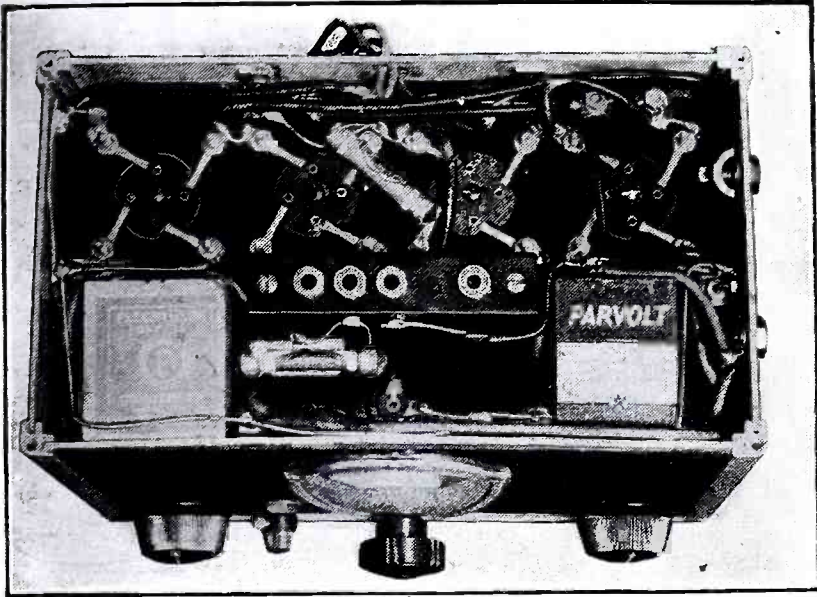

Top view of De-
Forest Short Wave
Receiving Set which
utilizes 4 tubes, the
metal cover being
removed to show the
tube sockets and
plug-in coil pin
sockets. This com-
pact receiver has
two stages of audio
and will operate a
loud speaker.

The sockets from which the vacuum tubes are suspended upside down are incorporated in this sub-panel. The two audio frequency transformers are mounted on the two end plates of the aluminum case, and the two midget variable tuning condensers as well as the variable resistance regeneration control are attached to the front panel. The resistances and remaining $2\frac{1}{2}$ microfarads of bypass condensers occupy the remaining space at the rear of the cabinet. For further simplification, the leads of the battery cable are soldered directly to their proper positions in the wiring, eliminating all binding posts and connections. All of these battery and telephone leads are bypassed to the grounded frame of the receiver.

Regeneration Control Feature

The tuning of the receiver is accomplished by means of a principal .0001 microfarad midget condenser, shunted by a .00005 microfarad vernier. The regeneration is controlled by means of a 25,000-ohm variable Super Tona-trol connected in series with the battery supply. As a precautionary measure, a 40,000-ohm fixed resistor is shunted across the secondary of the first audio frequency transformer, to prevent possible "fringe howl," or radio frequencies feeding into the audio amplifier.

The voltage applied to the tubes of the new receiver are as follows: R.F. plate, 90 volts; R.F. screen-grid, 45 volts; detector plate, 45 volts; first audio, 45 volts plate with a filament minus connection

for grid bias; second audio, 90 volt plate with $4\frac{1}{2}$ volts grid bias.

Any Size Aerial Works

The receiver in general is flexible, permitting its use in the smallest space and with almost any other type of tube desired, including the type -99 if dry cell operation is more convenient. Due to the aperiodic antenna circuit (a 5,000-ohm resistor) any length of antenna may be used without disturbing the calibrations of the receiver. Thirty feet of antenna was used in the laboratory, but equally good results were obtained with any other length of aerial.

The characteristics of the standard tuning coils are as follows:

The wiring of the receiver is

| Coil | Primary | Tickler | Wavelength | Threads Per Inch | Tickler Spacing |
|-------|-----------------|----------------|------------------|------------------|--------------------|
| No. 1 | 3 turns No. 18 | 3 turns No. 28 | 14 to 25 meters | 6 | $\frac{1}{8}$ inch |
| No. 2 | 7 turns No. 18 | 3 turns No. 28 | 23 to 49 meters | 11 | $\frac{1}{8}$ inch |
| No. 3 | 18 turns No. 18 | 4 turns No. 28 | 45 to 95 meters | 11 | $\frac{1}{4}$ inch |
| No. 4 | 26 turns No. 28 | 6 turns No. 28 | 93 to 105 meters | wound tight | $\frac{1}{4}$ inch |

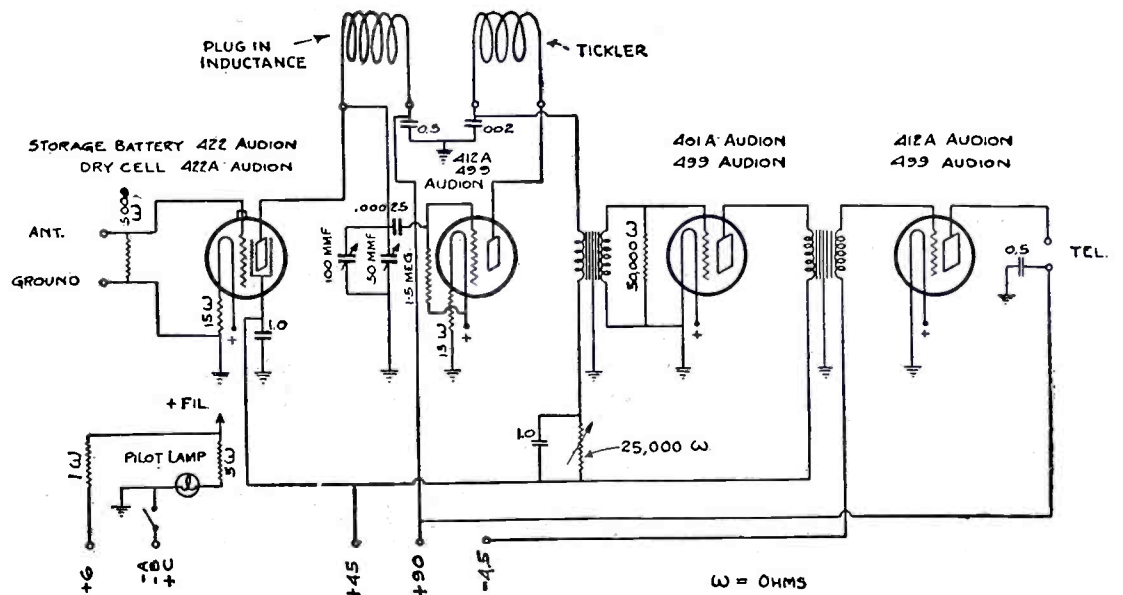

This diagram shows how the various parts of the new DeForest Short-Wave Receiver are connected.

easily reached, being entirely on the subpanel, between it and the top plate of the case. Great stability of operation is assured, as the longest lead in the oscillating circuit of the receiver is $1\frac{1}{2}$ inches in length.

Due to its many popular features and the fact that the tuning coils cover the popular DX band, the receiver has not been confined to industrial and governmental applications, but will be made available to the public.

The Only Place!
Where You Can Find All the
Latest
EUROPEAN NEWS
on
SHORT WAVES
Is In the Pages of This
Magazine

The next issue will contain the usual quota of
Short Wave Receiving Set
and other designs from the Laboratories of Europe's leading engineers.

The "Egert" SWS-9 Super-Het Short Wave Receiver

By JOSEPH I. HELLER, E.E.*

This new short-wave receiver of the Super-Heterodyne type, has a range up to 550 meters. Shifting a single, shielded plug-in unit, changes the waveband to which the set responds. The receiver is all A.C. operated and receives phone as well as C.W.

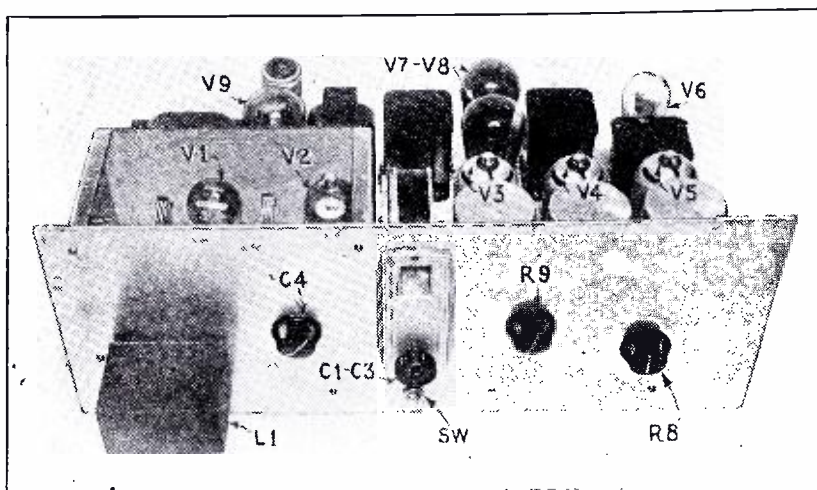

Fig. A
In this front view of the "SWS-9," the single plug-in inductance L1 is seen in its shield. This unit contains both oscillator and antenna coils, the details of which are shown in Fig. 4. The power pack, at the left, rear, introduces no perceptible hum. This set tunes with super ease.

IT has been conceded by many of the leading short-wave experts, that the super-heterodyne represents the last word in receivers of the high sensitivity, long range class. The short-wave super-heterodyne receiver about to be described embodies the results of over eight months of concentrated research. This receiver can be built up from a kit, with the assurance that it will work in a very satisfactory manner.

This super-heterodyne operates entirely from the 110 volt A.C. lighting circuit, without any disagreeable hum, thanks to the carefully designed amplifier circuits and plate supply filter.

One very important feature of any short-wave receiver, is that it should not be necessary to change more than one plug-in coil for each waveband desired. Furthermore the builder of such a receiver as this naturally expects sensitivity considerably above that of the ordinary short-wave set and also a selectivity sufficient to completely eliminate any chance of interference; with the gain at all frequencies practically the same in value. This receiver tunes in both short-wave broadcast and C.W. signals with equal facility and efficiency.

Simplification of All Controls

The disadvantages, of the ordinary set, to be overcome are as follows: absence of volume control; extremely critical and knife-edged regeneration control; a regeneration control whose setting varies with every frequency; plug-in coils that

make necessary a major operation in changing; low output; and, in most cases, two dial controls. This article is intended to cover each point in the design and construction of the "SWS-9 set"; and thereby to enable any experimenter both to see the worth and desirability of the ideas incorporated, and to construct this receiver with a minimum expenditure of time and effort.

Let us take the features desired and show how it was possible to evolve a rather rough idea of the finished set, by merely making sure that all of the desirabilities were included in the design.

First, we have non-critical control. As anyone knows who has ever tuned a short-wave receiver, the regeneration control is probably the most temperamental adjustment ever conceived for use in any set, whether broadcast or short-wave. The most sensitive portion of the detector's characteristic is at such an extremely critical point that, by the time a station has been sufficiently well tuned in to be audible, most of the pleasure has been eliminated from the proceeding.

The answer to this problem is to incorporate the regeneration control in such a circuit that it will be isolated from the frequencies being received; by so doing, it may be adjusted at the point of greatest sensitivity. The superheterodyne principle immediately comes to mind; and so it was decided the receiver must be a superheterodyne and thus free from critical regeneration settings. This circuit, too, has other advantages.

The problem of the plug-in coils was

a hard nut to crack. It was early decided that they would have to be operated from the front of the set, making it unnecessary to lift or remove any covers or to search around in the dark for sockets. Only one coil must be used. Since the design was a superheterodyne, and absolutely no hand-capacity effect from the coil was permissible, it became necessary to do two things: first, to put both oscillator and detector tuning inductances in the same unit; and, second, this unit had to be perfectly shielded. It will be seen, later, how neatly and effectively this last item was arranged.

Most manufacturers of short-wave receiver kits, for some strange reason, have repeatedly neglected to include volume controls, making it necessary either to detune the set, or lower the regeneration control (the latter expedient being impossible when receiving CW signals. Therefore, a volume control was included in the design.

In order to make the output equal to that of the ordinary broadcast set, it was decided that two type '45 tubes should be used in push-pull, preceded by a single '27 first A.F. amplifier. As a result, it was later found, after the construction and adjustments had been made, short-wave broadcast stations generally came

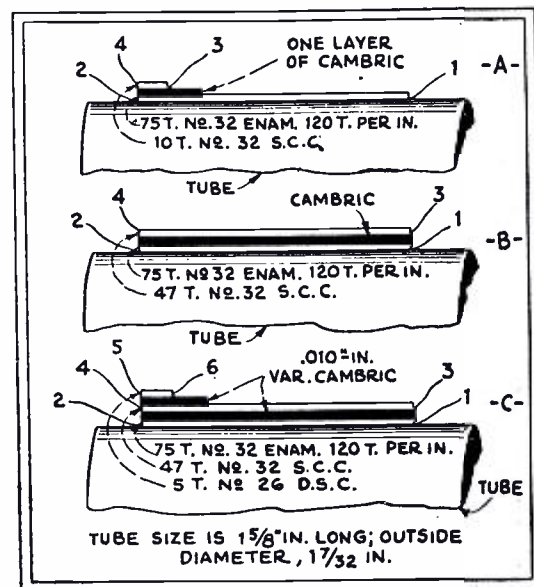

Fig. 2
Specifications of I.F. transformers, in the following order: A, L2; B, L3; C, L4—second-detector, with feed-back coil having terminals 5 and 6.

*Chief Engineer, Wireless Egert Engineering Co.

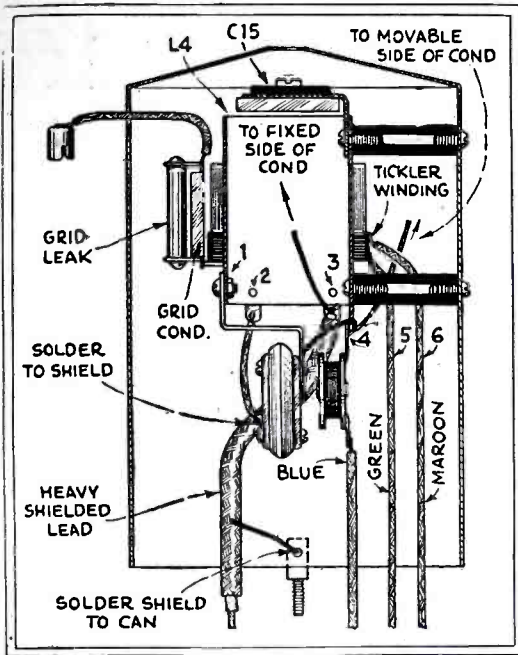

Fig. 3

Details of L4; the tickler winding, 5-6, does not appear on coils L2 and L3. The grid lead is shielded.

in with the same tone and volume as programs on the ordinary well-built broadcast receiver. This made possible, for the first time, the actual enjoyment of the program for its musical and entertainment value, in addition to the thrill of hearing a distant station.

When correctly used, the superheterodyne circuit is capable of exceptional sensitivity and selectivity. A major factor in obtaining both these effects is the use of the tuned air-core I.F. transformers L2, L3, L4 shown in Fig. 1.

Since very little amplification is necessary at the frequency being received (merely enough energy being required to beat with the oscillator), the gain is the same for all signal frequencies.

The regeneration control takes care of CW, ICW, and voice reception. When considering the problem of hum resulting from A.C. operation, it was believed that, if a perfectly-shielded supply source were placed properly, there would be no pickup of the hum. After quite a bit of experimenting, this result was obtained; and here is a receiver with absolutely no

hum, although the power-supply apparatus is mounted directly on the same chassis with the receiver proper.

After listing the desirable points, and their preliminary solution, complete specifications will be given for building the short-wave A.C.-operated superheterodyne receiver which looks like a broadcast set, tunes like a broadcast set and sounds like a broadcast set.

Assembly of the Receiver

Let us begin with the chassis, which consists of an inverted tray measuring 10 x 20 x 2 inches; it is made of 3/32-inch aluminum, bent over on all edges.

In the specifications which follow, both in the figures and in the text, dimensions for holes for audio transformers and chokes are not included; since it is felt that most constructors will prefer to use their own transformers. The placement of the transformers, in the factory model, however, is shown in the photograph reproduced here.

The shield can for the oscillator and first detector tubes and tuning condensers is made of 1/16-in. aluminum and measures 4 7/8 x 5 1/5 x 8 1/2 inches; it is provided with a cover.

The shield can for the inductances of the oscillator and first detector circuits is made of 12-ounce copper and measures 2 x 3 1/8 x 2 1/2 inches deep; into its rectangular opening fits a bakelite plate 2 x 3 1/8 x 1/4-inch thick, which is drilled for five General Radio pin-plugs (four of these being spaced 1/8-in., and the last one, to "polarize" the construction, 1 in.).

Since both oscillator and detector coils are wound on the same tube forms, the coupling between them is rather high. It is therefore necessary to use a high intermediate frequency (1,600 kc.) in order to prevent the detector from being blocked by the oscillator.

The specifications for the I.F. coils are given in Fig. 2; note that no two are alike. Care should be taken to wind exactly the specified number of turns in exactly the manner illustrated. It is not believed that any undue trouble will be experienced in the construction of these items; although, if you can buy them ready-made, this is preferable.

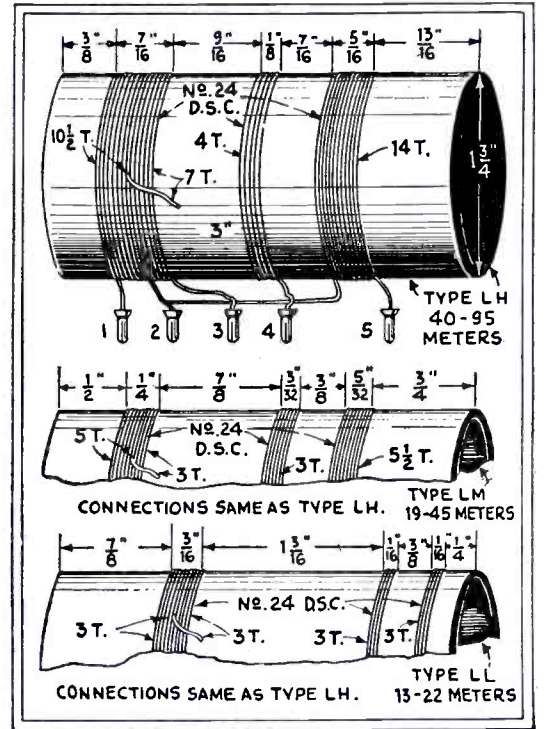

Fig. 4

Winding data for the short-wave oscillator and first-detector inductances, that are combined in one shielded coil unit, L1; this plugs into a front-of-panel receptacle, as shown in Fig. A.

A detail illustration of one of the I.F. inductances, L4, serves to illustrate the general construction of all three I.F. transformers. (Fig. 3.)

It will be noticed also that the filtering system for each stage is included in all but the first radio-frequency coil. Screen-grid tubes are used for both first and second detectors. In Fig. 4 are given the specifications for the three plug-in coils; these should be made with extreme care, since upon them depends to a great extent the frequency coverage possible with this type of set. In the regular factory model, the shields for these coils are made of 12-ounce copper, suitably bent and seamed, and heavily coated with crystalline lacquer.

The top (over-all) cover is made of steel, .036-inch thick; it measures, inside, 6 3/4 x 10 1/4 x 20 3/8 inches long (added to

(Continued on page 70)

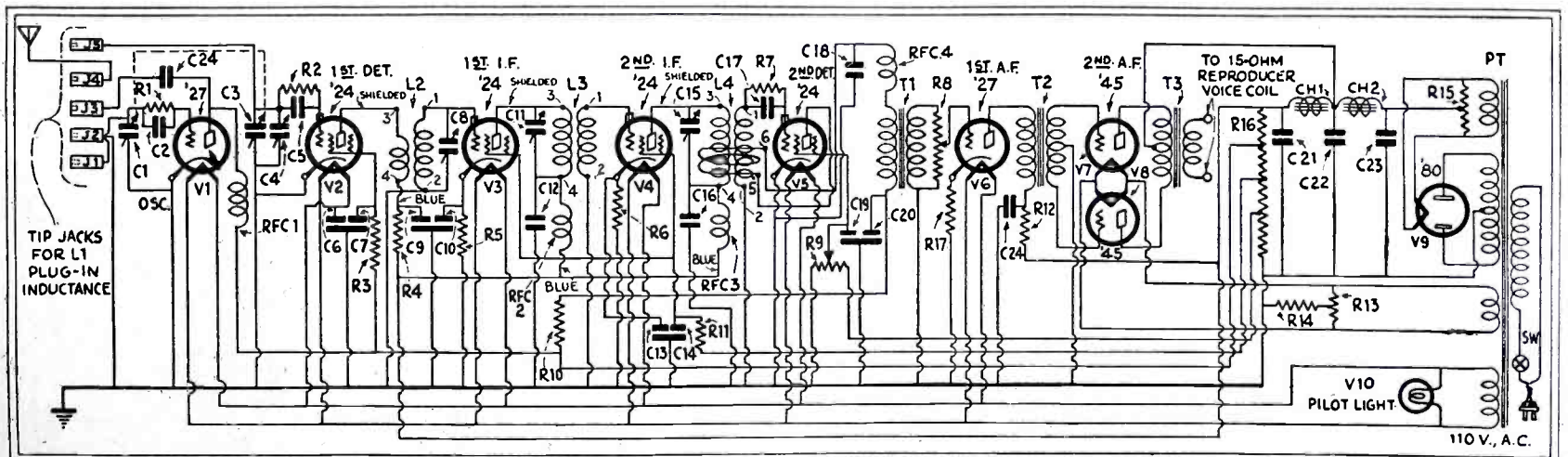

Fig. 1

Schematic circuit of the "SWS-9" short-wave super; the volume control is potentiometer R8, in the first audio input. R9 is a regeneration control for the second detector. The oscillator condenser C1 and antenna tuning condenser C3 are ganged.

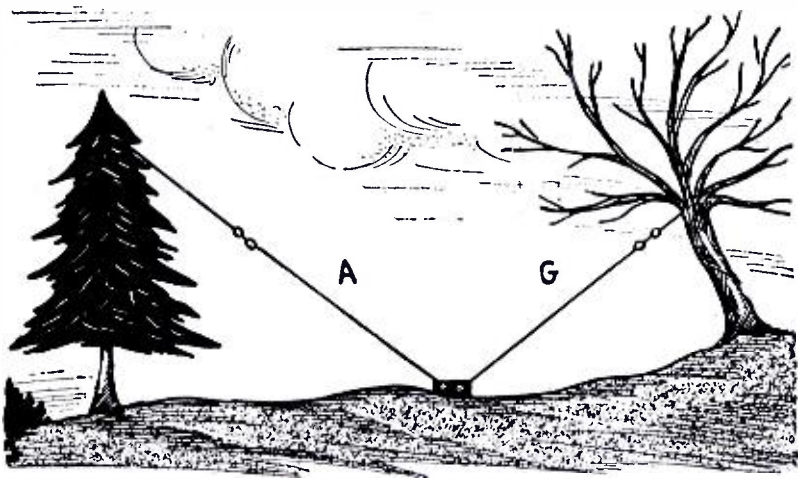

Fig. 3—Illustrates how "Suitcase" transmitter is connected to a dipole antenna.

PORTABLE S-W "SUITCASE" TRANSMITTER and RECEIVER

By R. WIGAND

THERE are various considerations to determine what hook-up to use. A portable transmitter must be equipped with a modern output tube, with very slight filament current drain, since one cannot take along large storage batteries. Small celluloid cells for box batteries, with the acid retained by glass wool, are preferable to so-called dry batteries, on account of longer life; though for rather brief excursions even a dry battery is sufficient. It is well known that, through the temperature fluctuations of the filament, the wave is greatly changed in the case of ordinary feed-back or regenerative hook-ups; this is especially noticeable when using the key.

There is the added point that swaying of the antenna is most unpleasantly evident; while travelling one cannot always set up the antenna perfectly. Even with transmitters of greater power, lack of constancy in the wave is so disadvantageous that other stations frequently fail to reply; then again, with low power, this is often the reason why one gets no response. This, together with the desire to be able to radiate a wave exactly known (to save using a wavemeter), settled the choice of the transmitter hook-up.

As Fig. 1 shows, a Huth-Kühn hook-up with quartz control was chosen. The advantages of the quartz control are

It is decidedly worth while to take along a short-wave radio set in one's luggage and to experiment a little with transmitting on low power, whether in the mountains or at the seashore. Even in a rowboat such a set can easily be installed and affords much pleasure. Herewith is described a portable set, consisting of a small transmitter and a two-tube receiver.

probably sufficiently known to permit the omission of a detailed discussion. The commonly held opinion, that a quartz transmitter of this kind does not permit getting the same effect out of the tube as, say, a three-point hook-up, is erroneous; at least if one uses a good quartz crystal. The results obtained by D4BY (Germany) a short time ago with such a transmitter from a row-boat, with the most primitive antenna conditions, were



Fig. 6—At right, shows author's arrangement of the transmitting parts.

Fig. 2—Below, at right, shows connections of parts in the Portable, Short Wave Receiver.

Fig. 1—Below, shows hook-up of Portable, Short Wave Transmitter.

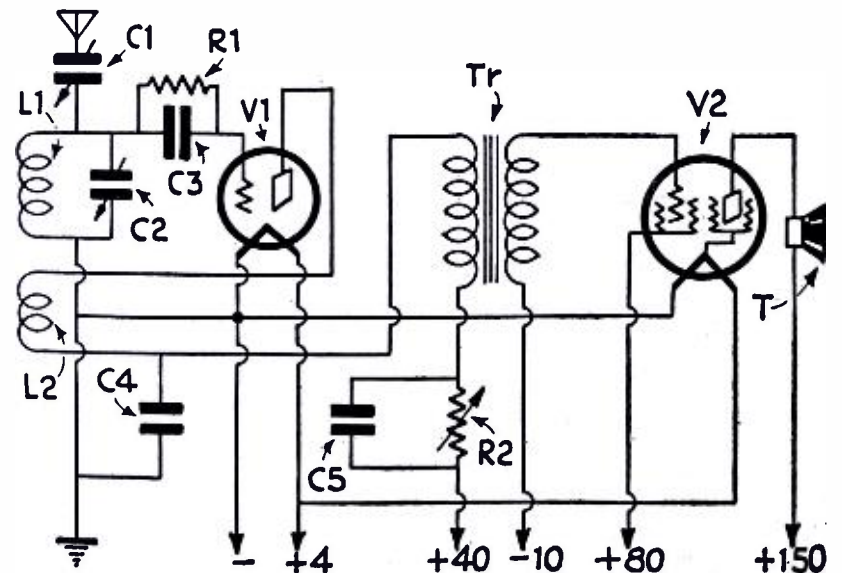
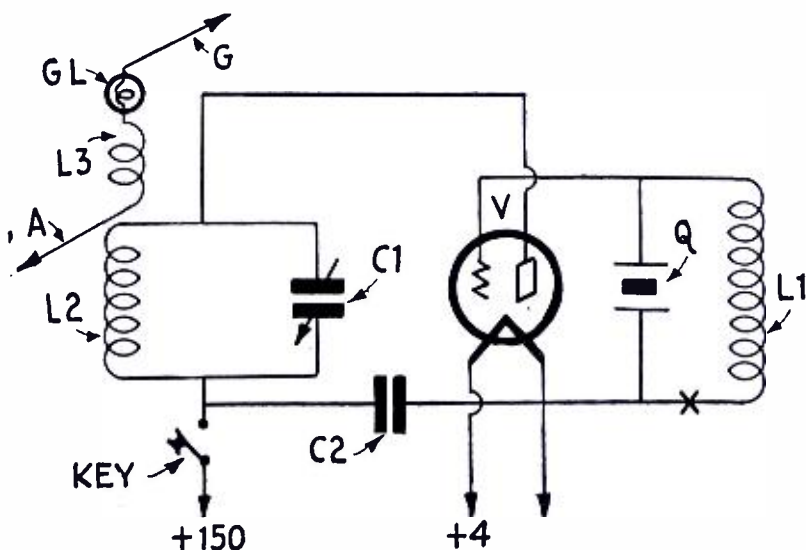
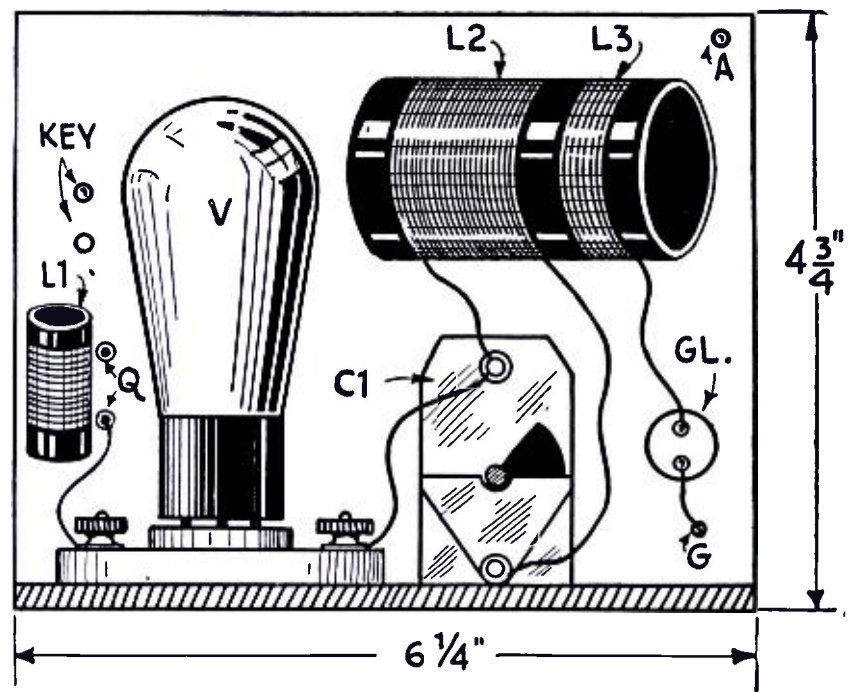



Fig. 5—The illustration at the left shows Portable Suitcase transmitter and receiver for short waves connected to an antenna of the Fuch's type.

two-way conversations with Japan, America, etc.; proving that with good radiation one accomplishes something, even with low power.

For antenna there is provided a dipole (31 feet in each half), stretched between the transmitter and two points as elevated as possible. (See Fig. 3.) By lengthening or shortening one arm, or by giving it more or less slope, one can get resonance without using a variable condenser, this being indicated by the maximum illumination of the little flashlight lamp G1. If this involves too much trouble, one can of course use a small variable condenser of 250 mmf. capacity.

The antenna coil L3 consists of 2½ turns of No. 12 to 15 D.C.C. wire, wound close together; while the plate circuit coil L2, contains 12 turns of the same wire; in this case the turns are spaced to the diameter of the wire. As a core for the coil, an insulating tube of 2 inches diameter serves; on this L2 is solidly fixed, while L3 is held together by a string and can be moved on the tube in order to change the antenna coupling.

The grid choke L1 is so adjusted that it has a higher frequency than the quartz crystal Q. For the forty-meter band (for which the above values are used) there is needed a winding of about 18 turns of No. 24 D.S.C. wire, wound on a diameter of about ¾-inch. The most favorable number of turns must be found by the experimenter; since it is dependent, not merely on the capacity of the crystal's receptacle, but also on the grid-cathode capacity of the tube.

Tuning the antenna circuit, because of the low operating voltages used, can safely be done with a small neutralizing condenser of about 100 mmf. capacity (C1); the bridging condenser C2 (.002 mf.) is an ordinary fixed condenser such as used in receiver. The key is connected in the plate circuit by means of two binding posts.

The arrangement of the individual parts is shown in Fig. 6. The approximate outside measurements are also

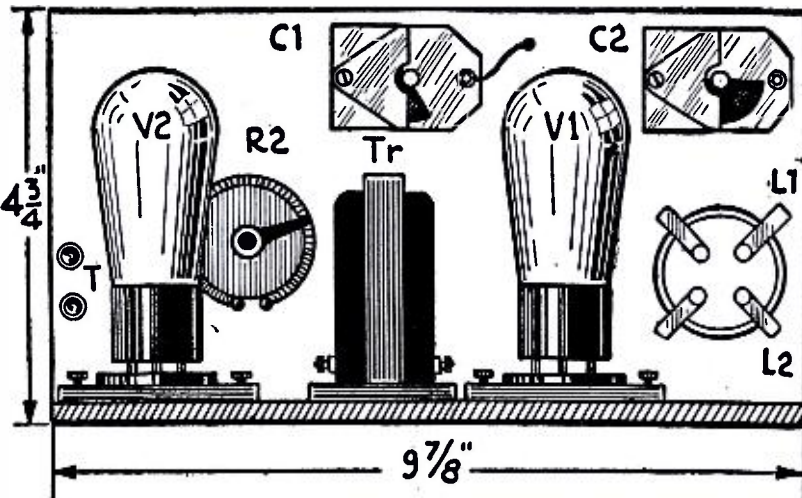

Fig. 7 — Illustrates the author's layout of the parts used in building the Portable Short Wave receiver here described. Other arrangements of the parts can be made of course, where the builder has some experience in this work.

given; but under certain circumstances the size might be reduced by careful construction. As plate potential an ordinary dry battery is used; its potential depends on how much weight one wants to carry. Generally one can carry a battery supplying 120 to 150 volts. For the filament, a little two-cell storage battery, or a dry 4½-volt battery will serve; for the latter a filament ballast is needed.

The receiver, in spite of the greatest possible saving in size and weight, must provide good reception. A regenerative detector and a transformer-coupled stage of amplification are necessary, as experience has shown. Since a relatively high plate potential is needed for the transmitter, anyway, there is no reason for making special economies in this respect; therefore a pentode output tube, which affords very excellent amplification, was provided.

Fig. 2 shows the hook-up of the receiver: C1 is "neutralizing condenser" of about 35 mmf. capacity for antenna coupling; C2 another like it, with a fine scale for tuning; C3 the grid condenser of .0001-mf.; C4 one of .001-mf. The bypass condenser C5 is 1 microfarad. The grid resistor R1 is of 3 to 5 megohms (according to the tube used). For regulating the regeneration, there is used the 50,000-ohm resistor R2; by this method one avoids, as is well known, undesirable changes in the wavelength. The value of the negative grid bias (indicated as -10), as well as that of the screen-grid potential (+80), depends on the value of the plate potential used. Coils L1 and L2 are wound on tube bases.

For 40-meter band, L1 has 14 to 16 turns and L2 8 to 10 turns; for 20 meters, L1 has 6 to 8 turns and L2 4 to 5 turns. Fig. 7 shows the arrangement of the parts; even greater compactness might be obtained.

For the antenna, one can either connect together both halves of the dipole, or stretch a separate receiving antenna about 15 meters (48 feet) long at right
(Continued on page 62)

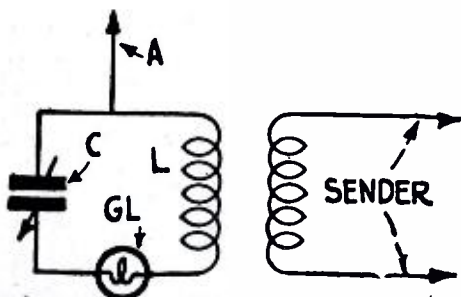

Fig. 4—Fuch's method of coupling the transmitting antenna; the small incandescent lamp (GL) is short-circuited when the set is in operation. A hot-wire meter is recommended instead of a lamp for tuning the circuit.

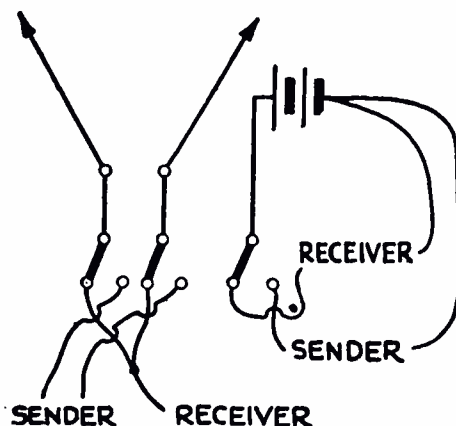

Fig. 8—(Center), shows switching arrangement for converting the dipole aerial to simple type for reception.

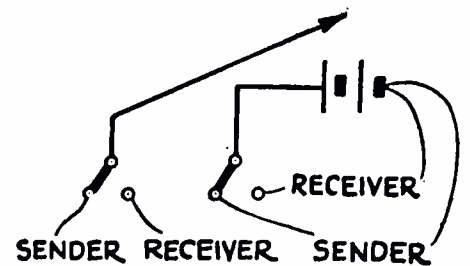
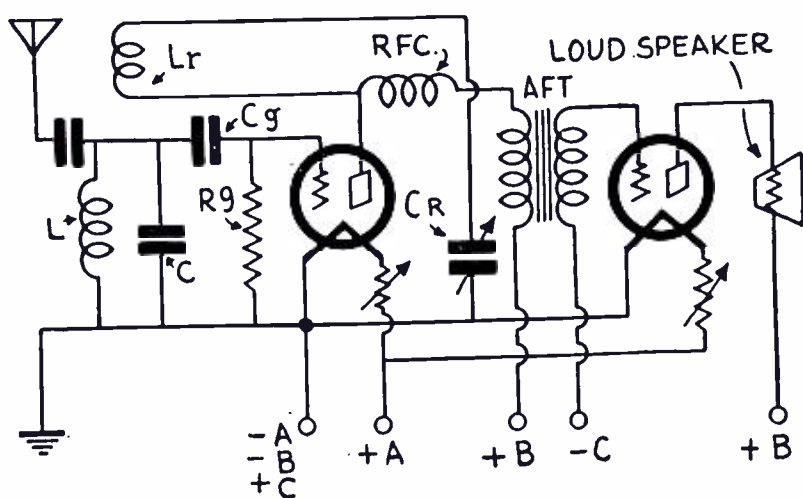

Fig. 9—Above, shows circuit for converting Fuch's type antenna for transmitting or receiving.

WHAT SHORT WAVE RECEIVER SHOULD I BUILD?

By ROLF WIGAND, DE0065
(Germany)



This article is a resume of the different short wave receiver circuits and Mr. Wigand gives us some very interesting sidelights on what we should look for and obtain in the better class of short wave receiving circuits. The article is of interest to those who "build their own," as well as to purchasers of factory-built sets.

Fig. 1. Typical two-tube, short wave receiver employing regeneration, controlled by a variable condenser CR.

ground. Every arriving wave produces a voltage drop across this, which is impressed across the grid circuit of a screen-grid tube. In the plate circuit of the latter is connected an impedance which, however, represents a resistance only at the one desired frequency. The variations in potential are conducted to the detector.

THIS article is intended, not to describe the construction of a particular short-wave receiver, but to bring out, by comparing several receiving hook-ups, what is most worth knowing of the practice of short-wave receiver construction and thus to place every short-wave listener (especially the novice) in a position to find out the arrangement most suitable to his conditions.

2 Tube Sets

A receiver type very extensively used has only two tubes (Fig. 1); particularly where only headphone reception is required, and the local conditions are favorable, one can get along with a regenerative detector and one stage of audio-frequency amplification. The antenna is capacitively coupled to the tuned grid circuit (LC); the regenerative coupling is inductive (Lr) and is regulated by the condenser (CR). The radio and audio-frequency currents follow parallel paths in the plate circuit; the first through CR and the latter through RFC and the primary of AFT. The choke RFC serves to separate them. This is the Leithäuser-Reinartz circuit.

If the strength of the signals received is not sufficiently audible then another stage of audio-frequency amplification is added, by either transformer or resistance coupling (Fig. 2), so that many transmissions and especially the powerful short-wave broadcaster and transatlantic telephone, can be received on the loud speaker. In this diagram the antenna is inductively coupled, and also the regeneration which, as before, is capacitively regulated. Radio and audio frequencies here follow the same path, through the tickler; then the high frequency currents are by-passed by the capacity CR, which offers less reactance

than the high inductance of the primary of AFT.

With either inductive or capacitive coupling of the antenna, not only does the damping effect of the antenna partly alter the characteristics of the tuning circuit L-C, but also the fundamental frequency of the antenna and its harmonics make themselves unpleasantly noticeable, through the so-called "dead spots" in tuning. This necessitates varying the coupling; and the effects of different kinds of antennas alter the tuning. Finally also—especially when tuning to the natural wave of the antenna, or its multiples—the oscillations produced by the receiver are radiated out and can disturb other short-wave listeners over a wide radius. All this causes a search for a mode, of coupling the antenna to the set, which does not show these disadvantages.

Screen Grid Tube to the Rescue

Here, as in many cases, the screen-grid tube comes to the rescue. (Fig. 3) a non-inductive non-capacitative resistor is placed in series between antenna and

Fig. 2. Typical three-tube, short wave receiver with the regeneration controlled by a variable condenser and employing one stage of transformer A.F. coupling, with a second A.F. stage resistance coupled.

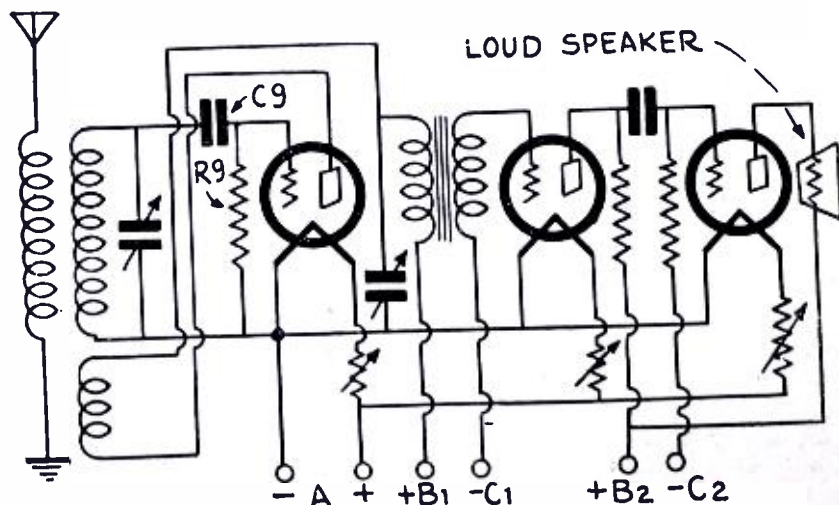

there is connected in this a radio-frequency choke coil RFC.

How to "Smooth Up" the Regeneration

A further difficulty, in regenerative sets, is often that oscillation, either comes in very harshly, so that telephony is hardly receivable; or else so feebly that it is hardly noticed, in which case the signals are weak. To regulate correctly the operating point of the detector tube, it has proved advantageous, not to connect the grid return directly to "A plus" or "A minus" but to search by means of a potentiometer (Fig. 3) for the most favorable working grid bias.

To avoid the passing over of radio frequency current into the audio-frequency amplifier, a by-pass condenser and a choke RFC are provided in the plate circuit of the detector. Radio frequency in the A.F. amplifier often causes the failure of a receiver. Howling of the amplifier—continually or at the start of oscillation in the detector—distortion, house-line troubles, etc., are frequently annoyances of this kind.

Tone Selectors

A painful fact, for the short-wave amateur, is the great crowding of stations on the amateur wavebands. Since nearly all the stations have abandoned

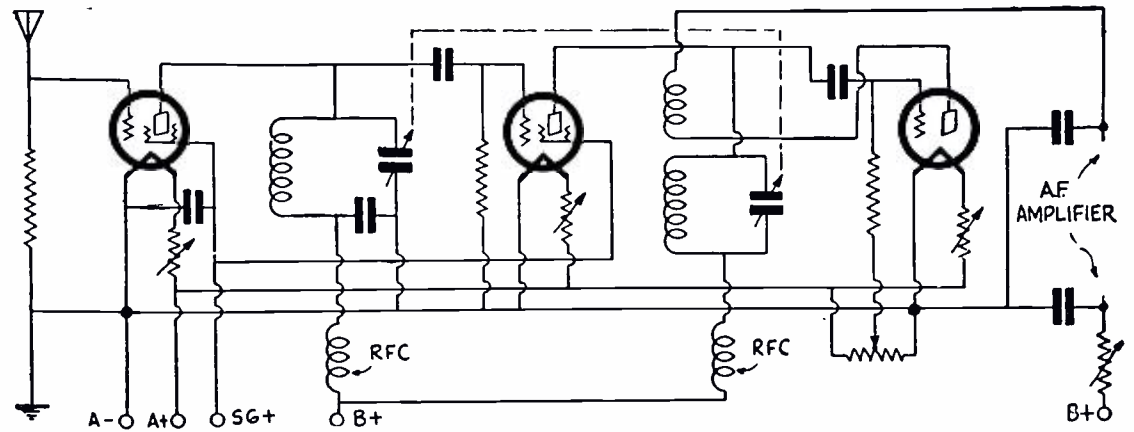

Fig. 4. Typical short wave receiver circuit, using ganged condensers for tuning the inductances and having the aerial resistance-coupled to the first R.F. tube.

along with it, may vary from this locally-generated frequency only 300 cycles; so that a 300-cycle note is also heard in the phones. At first, with an ordinary A.F. amplifier, both stations are heard at once and, if they are equally loud, then reception of signals is hardly conceivable. If, however, a tone selector, which is tuned to the 1,000-cycle tone, (and at a note only 100 cycles higher or lower lets through but 25 per cent of the highest voltage) is employed then, to be sure, the interfering stations will not be entirely inaudible; but the difference in

screen-grid tube, and puts in the plate circuit of the latter a circuit "S" tuned to the 1,000-cycle note. It then offers a considerable resistance to the alternating currents which are present in the plate circuit, if they are at or near 1,000 cycle frequency. Besides the considerable increase in freedom from interference from nearby stations, there is also the advantage of a great decrease in other undesirable noises. Since, under certain circumstances, telephonic reception is also desired, though impossible with such a set, there is provided a switch SW; by means of this, instead of the tuned circuit, a simple high ohmic resistance can be connected in. As the output tube, a pentode or (three grid-tube) is especially suitable on account of its great amplification.

Regeneration Control Methods

Besides these troubles of the amateur, the set may work very well otherwise, but the variation of the regeneration has a very great influence on the tuning of the grid circuit. Adjustment of the degree of regeneration by changing the distance between the coils is hardly used now in short-wave operation. This method operates by both the change of the mutual induction and the change in capacity.

Capacitive regulation of regeneration with stationary coils is probably most widespread, and the tuning difficulties here are less. Even here there is also often so much coupling that changing the regeneration makes the entire calibration of the receiver faulty. Now, there are also other methods of regulat-

(Continued on page 74)

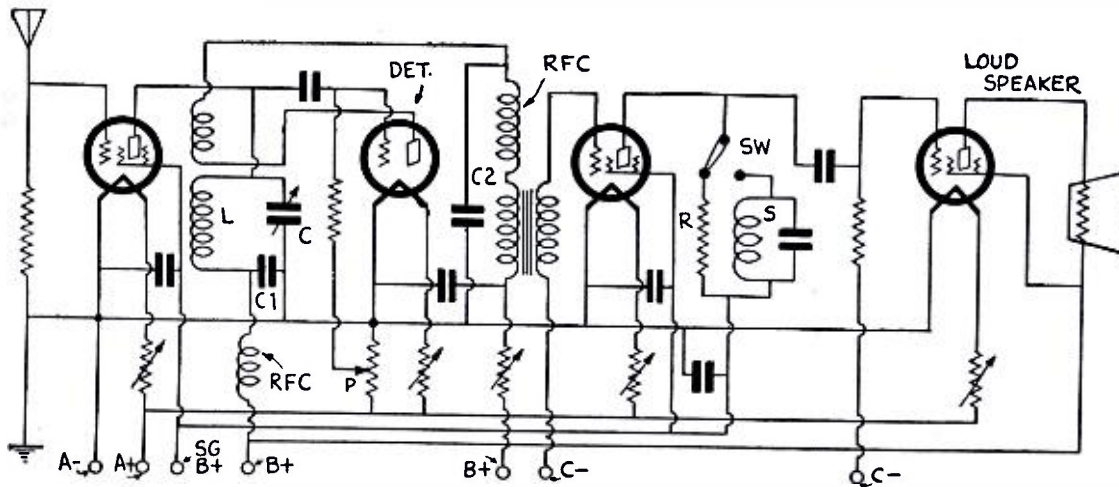

Fig. 3. Typical short wave receiver circuit of modern type using one stage of screen grid, R.F. amplification ahead of a regenerative detector; a switch in the first audio stage permits of using a "tone selector" S for code work.

the use of unrectified A.C. as plate potential, and only "pure tones" are usually heard in the ether, it is relatively easy to help matters here. Those who were occupied with "wireless," even before the beginning of radio, know that in telegraphic reception on long waves they often used to hear several stations at once. For selectivity, it was necessary to employ tuning, not only in the R.F. amplifier, but also at the A.F. end. This is done with a so-called "tone selector," which lets through only one audible tone and its immediate audio-frequency band; all other sounds are more or less suppressed.

This "tone selector" may be used in short-wave reception with the greatest success. If one, for example, tunes in a station, on an oscillating receiver, and beats the signal with a frequency 1,000 cycles away from the carrier, he hears the signal with a 1,000-cycle note. Another station, received at the same time,

received volume will be so great that the desired signals can be plainly distinguished.

Also, for this purpose, the screen-grid tube is well fitted. One simply connects behind the detector an amplifier with a

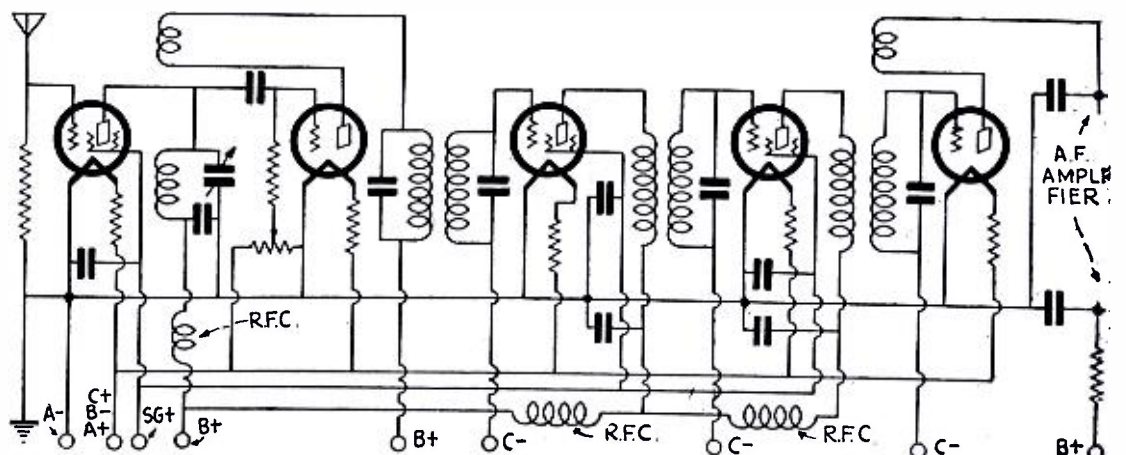

Fig. 5—A Super-Het short wave receiver of the "Autodyne" type.

2 VOLT TUBE RECEIVER

By JOHN CARTER

An efficient, three tube, S-W receiver, designed for the new 2-volt battery type tubes. "A" and "C" current supplied by 6-volt storage battery.

DURING the past two years it has become more and more evident that the popularity of the short-wave receiver is gaining in its stride; and, probably in the near future, it will outdo the present broadcast receiver for popularity. While it is admitted that short-wave receivers are in the experimental stage and that the multi-stage short-wave receiver does not give the same gain per radio-frequency stage as the broadcast receiver, nevertheless we are past the one-tube "blooper" day; since sensitivity with selectivity is impossible of obtainment without a tuned circuit ahead of the detector.

With this thought in mind, the circuit shown in Fig. 1 was designed for amateurs who want a receiver which is more sensitive than most short-wave receivers and yet uses only three tubes. The success or failure of this circuit depends upon using high quality parts and components, for the filament voltage cannot be raised to force the tubes. Apparatus having very low losses should be used; shielding is absolutely essential, but its shielding must be large and thick enough to introduce no losses.

Why I Like Batteries

The two most important factors governing performance of a short-wave receiver are tubes and high-quality parts. It is rather difficult (almost impossible) to say whether A.C. or battery tubes are the best; as both have their good features. The A.C. tubes have more rugged filaments and better amplification qualities, also without the bother of troublesome batteries; but extraneous noises from the power-supply line frequently

make distant reception impracticable and, sometimes, it is virtually impossible to eliminate these noises. The advent of the new two-volt battery tubes, however, does away with the difficulties experienced with A.C. tubes and their older brothers, the five-volt tubes, and simplifies everything.

The type '32 is ideally suited for the radio-frequency stage, having an amplification factor of 580; while its control-grid-to-plate capacity is only 0.020 mmf. This high amplification factor and low capacitance make possible a high voltage gain in this stage. In preliminary experiments the screen-grid tube was also used as a detector, but it proved very microphonic when coupled to a transformer stage of audio; which is quite objectionable, especially when trying to tune in distant stations. To eliminate these noises the transformer of the audio stage was changed to one of resistance

coupling, but there was a noticeable drop in volume.

Since only one stage of audio amplification is used, a type '30 tube was substituted for the '32 in the detector stage; and great improvement, both in gain and quality, was noticed. A '30 is also used in the audio stage.

Filament and Biasing Voltages

All radio tubes (and especially the two-volt type with their finer filaments) are delicate precision instruments and should be handled accordingly. Over-voltage on any tube lowers the efficiency and length of life. A voltage of 2.5 volts applied to one of the new tubes overloads the tube 25% and impairs its life of usefulness; it is also apt to burn out the filament. The permissible voltage range for operating these tubes efficiently is from 1.8 volts to 2.2 volts.

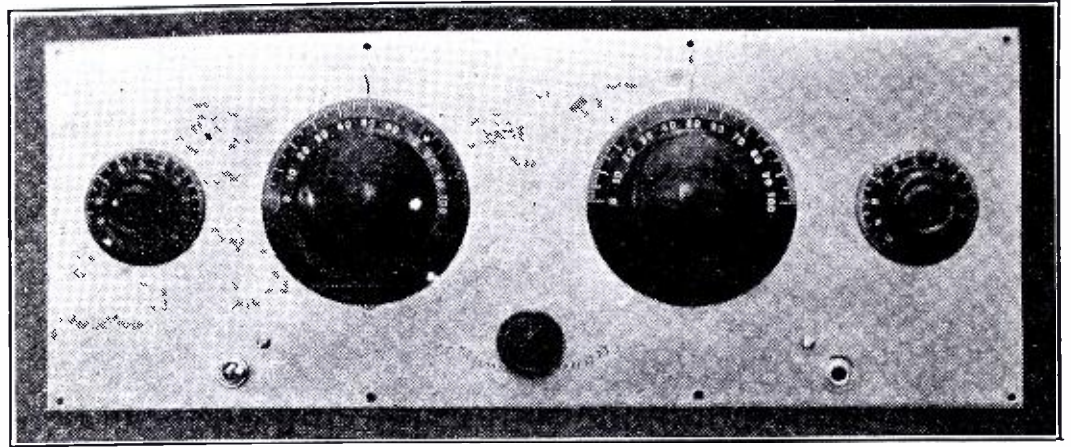

Front view of short-wave receiver especially designed by the author for use with the new two-volt, battery type tubes.

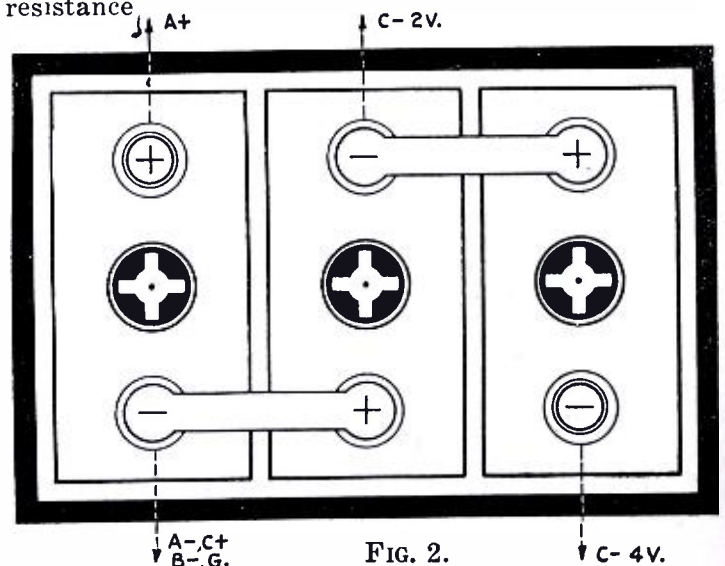
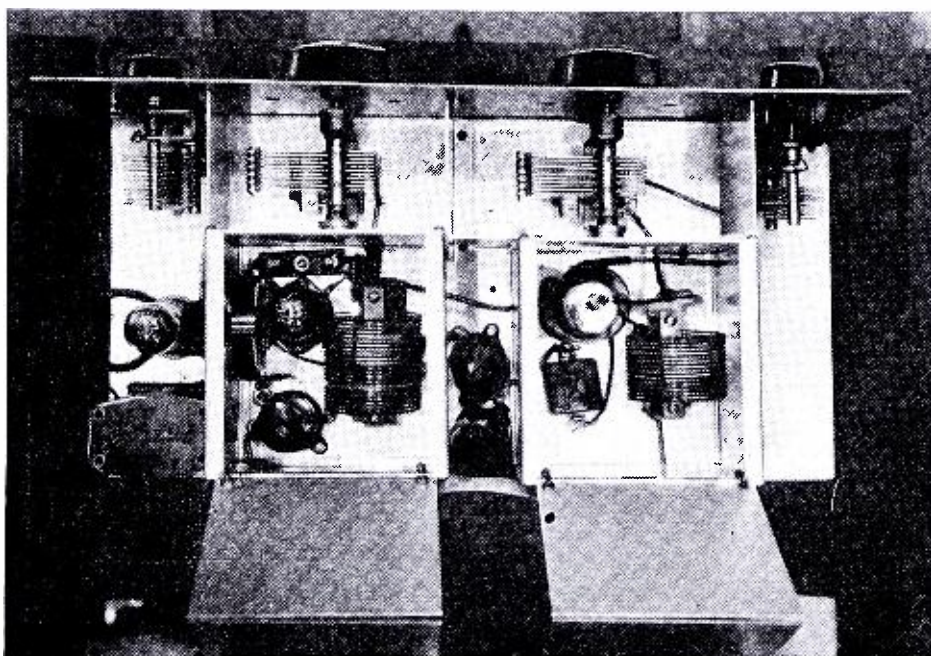

Diagram above shows how the author provides "A" current at 2 volts, also "C" voltages of 2 and 4 volts from standard, six-volt storage battery.

Left: Top view of two-volt, short-wave receiver, with lids of shield boxes open.

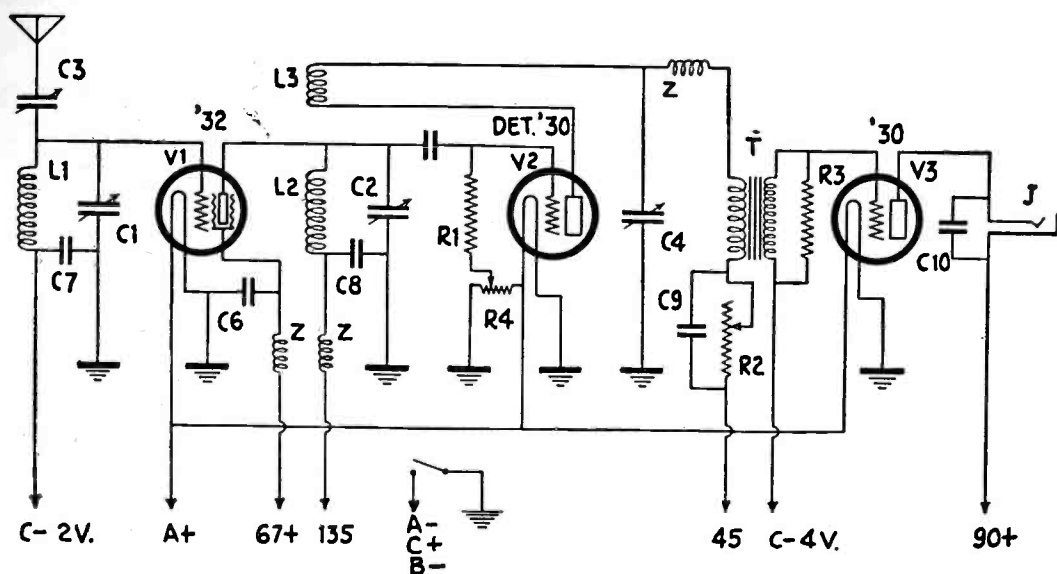

FIG. 1.

The usual method for controlling filament voltage is with a fixed resistor and a variable rheostat for critical adjustment, but without a voltmeter this is purely guesswork. To overcome this difficulty, and gain an advantage, the method of using a single storage cell has been adopted; this eliminates the use of all rheostats and resistors.

How Bias Current Is Obtained

The total current consumed by the filaments in this circuit is 0.18-ampere. Since a 6-volt storage battery is almost universally used, and only two volts are required for the filaments, we utilize the remaining 4 volts to obtain "C" bias in a novel way without resistors. The connections taken from the "A" battery are as follows (see Fig. 2); the highest positive lead is run to "A+" on the set. The negative terminal of the first cell connects to the "A-," "C+," and the ground connection of the set. The negative terminal of No. 2 cell provides the "C" bias for the radio-frequency tube; and the negative terminal of No. 3 cell supplies the "C bias" for the audio tube.

Trickle Charge Keeps Battery Up

The load drain on a 100-ampere-hour storage battery is very small. The cell supplying the filament current has a drain of 0.18-ampere, and the two remaining cells used for the "C bias" supply only a few microamperes. Though the current drain is unequal, as regards one cell, it is compensated for by the internal losses produced by the inactivity of the other two cells. A battery lying idle loses about .08-amperes (or 1.92 ampere hours per day) and the current taken by this receiver if used 10 hours a day, amount to 1.8 ampere hours. A trickle-charge rate of about half an ampere, five hours a day, will always keep the battery fully charged. In using this method it is impossible to overload the filaments; since the voltage of a single cell, when discharging, never exceeds 2.2, and a cell of 100-ampere-hour capacity, in fairly good condition, will deliver a voltage of two volts at this discharge rate for a period of about three weeks without any charge.

The Circuit Used

The circuit comprises a stage of radio-frequency amplification; a detector regenerative by means of the tickler or

condenser; C9 is shunted across the rheostat in the detector plate lead and C10 across the headphones. Chokes (Z, Z) are used in the plate and screen-grid leads of the radio-frequency stage and the detector plate.

The detector's grid return connects to the arm of a 400-ohm potentiometer which is shunted across the filaments; this is well worthy of inclusion, as it aids greatly in securing selectivity—a very important factor in a short-wave receiver. A 100,000-ohm rheostat, R2, in series with the detector plate lead, controls the plate potential; it is mounted on a bakelite strip at the rear of the set and, by using an extension rod, is connected to the knob in the center of the panel.

Condensers C1 and C2 are of 125 mmf.

Wiring diagram for the two-volt, three-tube, short-wave receiver is shown above, and includes one shield grid R.F. stage, ahead of regenerative detector.

Another view of the two-volt, three-tube receiver, showing shields over the midjet condensers.

Layout of the principal parts of Mr. Carter's receiver is given below.

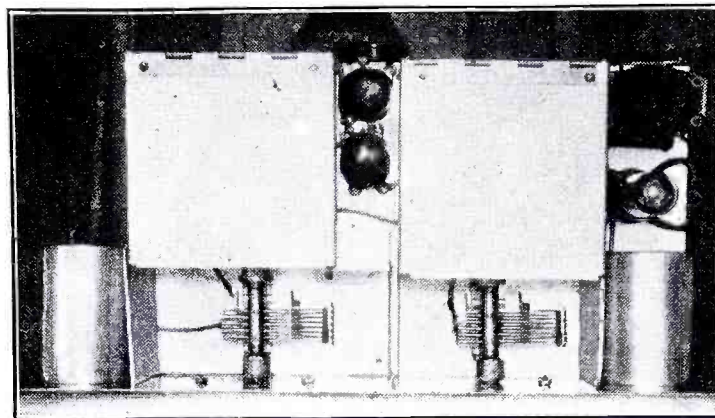
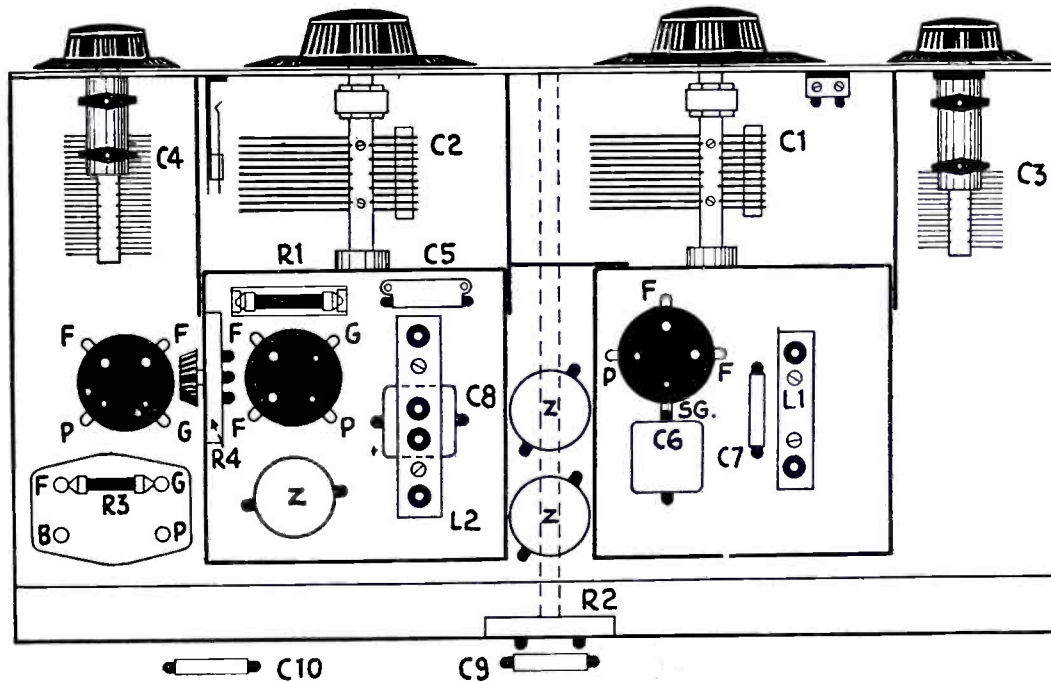

FIG. 3.



feed-back coil; and one stage of audio amplification, transformer coupled. Each circuit is completely shielded from the others. A very usual circuit; but the outstanding efficiency and sensitivity are due to the careful design and the use of modern parts, with their very low losses, which manufacturers have recently succeeded in developing. There is also a liberal use of chokes and condensers, each and every one an requisite which should not be omitted.

Of the capacities shown (Fig. 1) C6 is the usual by-pass condenser in the screen-grid lead; C7 is used to ground coil L1 and prevent short-circuiting the "A" battery; C8 is used as a blocking

capacity, very ruggedly constructed, with extra wide spacing between the plates. When they are used with properly-designed space-wound coils (three inches in diameter) there is a maximum of inductance and relatively small capacity. This is the best method of securing all around efficiency over the entire short-wave band and, in the crowded amateur band, it is easy to secure close tuning that separates stations.

Mechanical Assembly Details

The mechanical assembly of the parts, together with the shielding, is not difficult and anyone handy with tools should (Continued on page 71)

AMONG THE "HAMS"

MARS NEXT!

Editor, SHORT WAVE CRAFT:

Here is a photo of my short-wave radio station, W3BET. My station has been licensed since September, 1930, and the outfit as arranged in the picture is as follows:

At the extreme left is the frequency meter; Hartley circuit used in the transmitter which is directly under the antenna panel. 750 volts on 210 tube, rectified with 281's and well filtered. The monitor is between the transmitter and receiver and is the heterodyne type; receiver is Super-Wasp and the plug-in coils for the receiver hang on the far wall. The small portable typewriter in front of the monitor is for cards and amateur correspondence.

Wishing your magazine all success. I am,
A. E. HOWARD, W3BET,

1007 Parker Ave.,
Collingdale, Pa.

P. S.—New Zealand is my longest distance!

(Glad to publish your awe-inspiring station photo, A. E. What we particularly liked about your letter is the innocent looking post-script about New Zealand. We haven't tried to figure it out exactly, but from where you are located we imagine that there is no possible longer distance than New Zealand, barring the Moon and "Old Boy" Mars.—Editor.)

WE SURE DO

Editor, SHORT WAVE CRAFT:

I read most every one of SHORT WAVE CRAFT that I can get hold of, and noticed in a recent issue an article devoted to the *International Short Wave Club* of Klondyke, Ohio, and I wondered if you would give the *Anglo-American Radio Society* a slight boost through SHORT WAVE CRAFT.

The society began through correspondence with Leslie W. Orton of England, and now has membership in England, Ireland, Hawaii, Honduras, Cuba, Holland, etc. It is an organization for everyone interested in radio and its advancement, and has among its members "DX" fans, radio amateurs, short-wave hounds, and experimenters. It is a non-commercial organization, established to help its members, and has as an ultimate aim the fostering of good will between the nations.

We charge members \$1.00 per year for membership, with an extra entry fee of 50c, covering the cost of an attractive club pin. Each member receives a membership card, and a year's subscription to "CQ," our bi-monthly magazine, which contains practical long and short-wave articles, up-to-date schedules, and first class radio information. In the case of our long-wave members, we send out almost every week "DX" tips of what to try for on the air. Nothing has been decided upon yet to do for the S.W.E.R.S.

"CQ" may be issued monthly if articles are enough to warrant it, and branches are being organized in more foreign countries.

Any person who feels himself capable of organizing a branch in his country or city should write me for full particulars. We need assistance in South America, Central America, Mexico, and in many countries.

We have had a number of programs broadcast for us by courteous radio men throughout the world, and we inform each member of each program, so that he may be at his dials to listen.

THE ANGLO-AMERICAN RADIO SOCIETY,
Lacon, Illinois.

JOHN MALONE,
Executive Secretary,
American Branch.

(We are glad to publish Mr. Malone's letter as we should be glad to publish those of any other radio society. SHORT WAVE CRAFT has an open-minded policy and its purpose is to encourage any and every form of "short-wave" activity. The more societies, the more converts; the better we will all like it and the faster the art will advance.—Editor.)

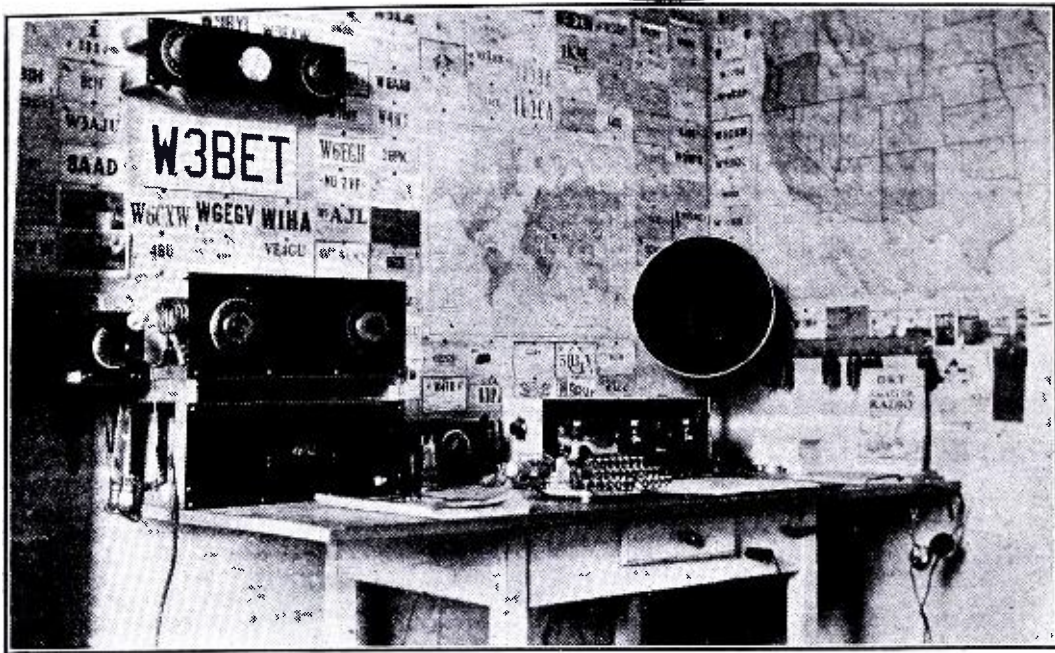

W3BET—The business-like, short wave amateur station, operated by Mr. A. E. Howard

A "HOT" SUGGESTION

Editor, SHORT WAVE CRAFT:

Just a line to let you know how I like SHORT WAVE CRAFT. It is the real book for the "Ham" and the only one I have found for the one who is just starting out. I am sending with this letter a photo of the "beloved junk pile" and hope to see it in an early issue.

I would like to offer one suggestion and one that I believe would be a good thing for SHORT WAVE CRAFT.

Suppose you add a department where the Hams could advertise their used parts which they may want to sell or trade.

I frequently would like to buy such parts and I know other Hams do too. I think this would help both SHORT WAVE CRAFT and the Hams.

I am not a "DX" hound but like to be friendly with the "local boys".

Sincerely,

F. D. BUCHANAN,
W9DVH,
404 N. Oak St.,
Owatonna, Minn.



W9DVH—The neat "ham" station operated by Mr. Buchanan.

(Now boys, don't all shout together, but here is a real honest-to-goodness suggestion and we were waiting for it, because we did not wish to broach the subject ourselves. Therefore beginning with the next issue let this be an official announcement that we shall be glad to receive your classified advertisements so you can advertise parts and used parts which you wish to sell or trade, to your heart's content. We are opening a special classified advertising section for this purpose and we are making the rate exceedingly low, in order to help the good work along, namely 2c per word.—Editor.)

MORE RESULTS

Editor, SHORT WAVE CRAFT:

I am writing this letter to tell you that I have built the *double detector* short-wave set described in your October-November issue. Instead of using the regular primary of the Pilot Wasp coils, I employed an aerial condenser.

Well, in the past two weeks I have picked up the following foreigners: RV15 at Khabarovsk; KGRN at Manila; F31CD at Saigon, Indo-China; PK3AN at Sourabaya, Java; GBU, England; LSX, Buenos Aires; VK2ME, Sydney; XPT at Laredo, Mexico; VK3ME, Melbourne; VE9CL, Winnipeg; LGN, Bergen, Norway; XDA, Mexico City; HKT, Bogota; and J1AA in Japan; CGA, Drummondville; and beside these I have heard about 20 stations in the U. S.

The double detector idea doesn't increase my volume any more than I had on my single detector set, but Oh! Boy! how it increases the sensitivity and selectivity!

I have read your magazine for about the last three issues and there is no other as good as SHORT WAVE CRAFT. Hoping that this letter will be of interest to other short-wave fans, I am

GEORGE SINCLAIR,
809 E. Pine Avenue,
Compton, California.

(Some record, George, and we are really proud of you! This is the kind of dope we are looking for from you fellows and we cannot get too many of them. Keep us informed of your activities and if we do not publish your letter immediately, do not think it is because we don't want to. Sometimes we do not have the space and we always try to publish letters of interest to the rest of the "gang".—Editor.)

HOT DAMMIE!

Editor, SHORT WAVE CRAFT:

I have just finished reading Mr. Clarence Gerren's criticism in your Feb.-Mar. issue of SHORT WAVE CRAFT. It appeared to me at once that Mr. Gerren was not a dyed-in-the-wool amateur or for even that matter a sympathizer with the majority of radio operators. Quoting Mr. Gerren, "Graduated from the Institute and worked a 1 k.w. spark set (KFCN) on the Great Lakes. Learned nothing I hadn't known for several years; a great waste of time." If Mr. Gerren is a psychology student, as he claims, he should know that man never reaches the capacity of full knowledge. This, to me, sound rather inconsistent. May I ask, what is his definition of knowledge?

Here is another choice bit of inconsistency. Closing his letter he states that if guys would just forget their practical stuff "long enough to get useful" the world would be a much different place. In an earlier part he states that he has six inches of notebooks full of data he is not able to understand, and then caps the climax by admitting that practical men never do understand what they know about radio! I fail to follow Mr. Gerren's way of thinking.

Mr. Gerren might have combed the libraries for texts on radio principles in 1927 and found none, but it is evident that he stopped right there. It is also evident that he stopped his subscription to QST, for he would have found plenty of good source material in that magazine to pore over. Every month QST gives book reviews and lists texts useful to both engineer, technician or amateur.

It is a sad plight for one to admit that a magazine has outgrown its usefulness for his intellectual scope. A bit of destructive criticism for SHORT WAVE CRAFT and QST.

Frankly, I can't see where Mr. Gerren has offered a bit of constructive criticism. To the contrary it is not even organized, rational, thought!

Theory goes hand in hand with practice. The articles published in your magazine are all right. The majority of us will take a dash of the theoretical with the practical.

Yours truly,

CLARENCE A. BROCKERT,
W9DNU,
823 West Main St.,
Platteville, Wisconsin.

(Thanks, Clarence, for the lift. Your letter is so complete that adding some of our high-brow nonsense would only detract from it. So we leave it go at that and let the readers decide in their own minds just what's what.—Editor.)

W9BYY—Yes, sir, this transmitting station has phone equipment and is owned by Mr. Denhart. (Note the microphone in the foreground.)



THOSE CARDS

Editor, SHORT WAVE CRAFT:

Already belonging to "The Ancient Order of Dial Twisters," "The Nite Owl Radio Club," and others; I am more than anxious to become a member of SHORT WAVE CRAFT'S "SHORT WAVE PHONE HOUND CLUB."

I honestly believe that SHORT WAVE CRAFT is the best all around Radio and Short Wave magazine on the newsstand today. Your magazine is extremely notable for its help to not only the beginner, or the advanced "Ham," but to all the radio enthusiasts combined.

I have followed your magazine in its growth and think it has topped them all for a long time, when it comes to real Short Wave, up-to-the-minute dope. Herewith is a photo of my experimental station. My different sets were nearly all taken from articles from your magazine; foremost of which is the transmitter shown in the center of the photo. Many of the other instruments (mostly homemade) were built from instructions printed in your magazines of earlier issue.

I wish to thank you for the fine magazine you are publishing and wish you would quote me the price of your S. W. P. H. Cards, as I would like 100 of them soon.

Your for an even better magazine in the future, I remain,

OREN L. DENHART, W9BYY,
205 S. Lynn St.,
Urbana, Ill.

(We have had a heart-to-heart talk with "Fips" the office boy, about those Short Wave "Phone Hound" Cards. He told us that he has had a terrible lot of trouble with his artist and has not been able as yet to get the right design for his cards. We overheard him arguing the other day with an artist because "Fips" wanted the design made entirely of radio waves, with a blood hound interlaced with the waves. He did not work it out as yet and he is still at it. As soon as he finishes with the design you will see it published and the cards will be advertised for sale—that is if the artists do not give out.—Editor.)

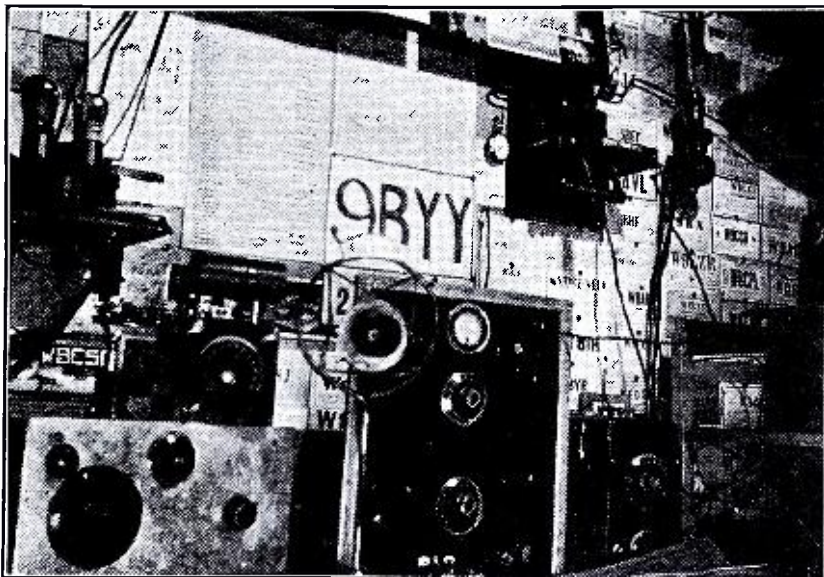

HOO-RAY FOR MR. TANNER

Editor, SHORT WAVE CRAFT:

Just a line to let you know I have built the "Tanner" Television Receiver and have it working fine—the best I have built yet for Television. I have been receiving television down here extra-good in fine weather. I am using a scanning drum, as I like it better than a disc.

L. J. MCGEE,
Winston-Salem, N. C.

P. S.—Don't completely cut television out of SHORT WAVE CRAFT.

(No, L. J., we certainly will not cut television out completely from SHORT WAVE CRAFT. The two arts go together and just because SHORT WAVE CRAFT has a sister, TELEVISION NEWS, there is no reason why we should not have occasional articles on television and you will find them from time to time.—Editor.)

WE TICKLED HIS PALATE!

Editor, SHORT WAVE CRAFT:

Just a word about the last issue which I received. It is the best issue that I have read, the articles on portable short-wave transmitter and receivers, phone transmitters—employing ABC amplifiers are good, and the article on The International Time-Zone Chart and Converters was just what I was looking for.

RUDOLPH VON DOHLEN,
2047 Terrace,
Port Richmond, L. I. City, N. Y.

(Thanks a lot, Rudolph, but if you fellows do not stop sending us complimentary letters, we will have to quit soon. Is it possible that we are 100% perfect and that no one has a kick? Let's have your brick-bats once in a while, as it may keep us from getting a swelled head.—Editor.)

\$2000.00 Radio Contest

\$2,000.00 IN PRIZES FOR THE BEST DESCRIPTION, MOST NOVEL "Q. S. L." CARD AND PHOTO OF STATION

IN the last issue of SHORT WAVE CRAFT we announced a \$2,000.00 prize contest, open to Short Wave "Hams" and others everywhere. Approximately \$2,000.00 in radio merchandise will be awarded in prizes by the editors, who will act as the judges in this contest. The prizes will be awarded to those submitting the most interesting photograph of an amateur station, together with the best short technical description of the set and the most novel "Q.S.L." card. For the benefit of those who did not read the announcement in the last issue of SHORT WAVE CRAFT, we are repeating the rules of the contest, below. We have also advanced the closing date of this contest from April 10, 1931, to June 10, 1931.

The rules of entry are very simple and for one thing we would like to mention, that if you think anything at all of your station, do not attempt to waste your own time and that of the judges, by sending in one of those "foggy" half-out-of-focus photographs, as you will be practically nullifying your chance of obtaining a prize. The old saying is still a good one—to wit: "Anything worth doing at all is worth doing well." If you are not a good amateur photographer

you had better call on a friend or a professional photographer to take the picture of your set. The apparatus must show up clearly and distinctly and it is a good idea, if at all possible, to pose yourself with your set, when having it photographed. However this last request is not an absolute requirement.

With further regard to what the judges have in mind for the most novel "Q.S.L." card, no very definite rules can be laid down as the range of ideas will run the entire gamut from the ridiculous to the sublime.

The description of the set need not be more than 150-200 words in length, but it must be written up in an interesting way.

RULES—Send a good (clear) photo of your set, at least 5 x 7 inches; also "Q.S.L." cards and description, including following data: Power in watts (input to last stage) of station? Wavelengths usually used? At what hours (Greenwich Civil Time) do you operate? Crystal control? Phone? You do not have to be a subscriber to compete. Address all entries to: Editor, Radio Amateur Prize Contest, SHORT WAVE CRAFT Magazine, 98 Park Place, N. Y. City.

Up to the time the magazine went to

press, we are glad to announce the names of the radio manufacturers who have contributed merchandise to be awarded as prizes by the judges of this contest:

- Pilot Radio & Tube Corp., Lawrence, Mass.
- The Ken-Radio Corporation, Inc., Owensboro, Ky.
- Universal Microphone Co., Ltd, Inglewood, Calif.
- Electrad Company, Inc., New York City.
- International Resistance Company, Philadelphia, Pa.
- A. M. Flechthelm & Co., Inc., New York City.
- Trimmed Radio Mfg. Co., Chicago, Ill.
- X-L Radio Laboratories, Chicago, Ill.
- Triad Manufacturing Co., Inc., Pawtucket, R. I.
- Clarostat Mfg. Co., Inc., Brooklyn, New York City.
- Amperite Corporation, New York City.
- Ce-co Manufacturing Co., Inc., Providence, R. I.
- Hammarlund Manufacturing Company, Inc., New York City.
- Jewell Electrical Instrument Co., Chicago, Ill.
- National Company, Malden, Mass.

Short-Wave Stations of the World

| Meters | Kilo-cycles | Station Name | Location | Notes |
|-----------|---------------|----------------------------------|-------------------------------|---|
| 4.97-5.35 | 60,000-56,000 | Amateur Telephony and Television | | |
| 5.83 | 51,400 | W2XBC | New Brunswick, N. J. | |
| 6.89 | 43,500 | W9XD | Milwaukee, Wis. | Television. Milwaukee Journal. |
| 7.05 | 42,530 | | Berlin, Germany | Tu. and Thu., 11:30-1:30 p.m. Telefunken Co. |
| 7.32 | 41,000 | W8XI | East Pittsburgh, Penna. | |
| 8.67 | 31,600 | W2XBC | New Brunswick, N. J. | |
| 9.68 | 31,000 | W8XI | Pittsburgh, Pa. | |
| 9.93 | 30,200 | W6XD | M. I. T. Co. | |
| 9.96 | 30,105 | | Golfo Aranci, Sardinia | Telephone to Rome. |
| 10.51 | 29,190 | PK313 | Sourabaya, Java | Wed. and Sat., 5:50-7:50 a.m. |
| 10.79 | 27,800 | W6XD | Palo Alto, Calif. | M. R. T. Co. |
| 11.55 | 25,960 | G5SW | Chelmsford, England | Experimental. |
| 11.67 | 25,700 | W2XBC | New Brunswick, N. J. | |
| | | W3XA | Philadelphia, Pa. | Norden-Hauck El. Mfg. Co. |
| 12.48 | 24,000 | W6AQ | San Mateo, Calif. | (Several experimental stations are authorized to operate on non-exclusive waves of a series, both above this and down to 4 meters.) |
| 13.04 | 23,000 | W2XAW | Schenectady, N. Y. | |
| 13.92 | 21,540 | W8KK | Pittsburgh, Pa. | |
| 13.97 | 21,469 | W2XAL | New York | |
| 13.99 | 21,429 | XFA | Mexico City, Mex. | (Authorized to broadcast at any higher frequency.) |
| 14.00 | 21,420 | W2XDJ | Deal, N. J. | And other experimental stations. |
| 14.01 | 21,400 | WLO | Lawrence, N. J. | transatlantic phone. |
| 14.15 | 21,130 | LSN | Monte Grande, Argentina | |
| | | W2XAO | New Brunswick, N. J. | |
| 14.28 | 21,000 | OKI | Podebrady, Czechoslovakia | |
| 14.17 | 20,710 | LSY | Monte Grande, Argentina | Telephony. |
| 14.50 | 20,680 | LSN | Monte Grande, Argentina | after 10:30 p. m. Telephony with Europe. |
| | | FMB | Tamatave, Madagascar | |
| | | PMB | Bandoeng, Java | After 4 a.m. |
| | | FSR | Paris-Saigon phone | |
| 14.62 | 20,500 | W9XF | Chicago, Ill. | (WENR) |
| 14.89 | 20,140 | DWG | Nauen, Germany | Tests 10 a.m.—3 p.m. |
| 15.03 | 19,950 | LSG | Monte Grande, Argentina | From 7 a.m. to 1 p.m. Telephony to Paris and Nauen (Berlin). |
| | | DIH | Nauen, Germany | Press (code) 6:15 a.m., English; 8:30 a.m. and 11 a.m., French, daily. 8:30 a.m. Sundays. French. |
| 15.07 | 19,906 | LSG | Monte Grande, Argentina | 8-10 a.m. |
| 15.10 | 19,850 | WMI | Deal, N. J. | |
| 15.12 | 19,830 | FTD | St. Assise, France | |
| 15.20 | 19,720 | EAQ | Madrid, Spain | |
| 15.40 | 19,460 | FZU | Tamatave, Madagascar | |
| 15.45 | 19,400 | FRO, FRE | St. Assise, France | |
| 15.50 | 19,350 | | Nancy, France | 4 to 5 p.m. |
| | | VK2ME | Sydney, Australia | |
| 15.55 | 19,300 | FTM | St. Assise, France | 10 a.m. to noon. |
| | | PPU | Rio de Janeiro, Brazil | |
| 15.58 | 19,210 | DFA | Nauen, Germany | |
| 15.60 | 19,220 | WNC | Deal, N. J. | |
| 15.94 | 18,820 | PLE | Bandoeng, Java | 5:40-6:40 a.m. and from 2:40 a.m. Tues. and Fri.; 8:10-10:10 a.m. Tues. Also telephony. |
| 16.10 | 18,620 | GBJ | Bodmin, England | Telephony with Montreal. |
| 16.11 | 18,610 | GBU | Rugby, England | |
| 16.30 | 18,400 | PCK | Kootwijk, Holland | Daily from 1 to 6:30 a.m. |
| 16.35 | 18,350 | WND | Deal Beach, N. J. | Transatlantic telephony. |
| 16.38 | 18,310 | GBS | Rugby, England | Telephony with New York. General Postoffice, London. |
| | | FZS | Saigon, Indo-China | 1 to 3 p.m. Sundays. |
| 16.44 | 18,210 | FRO, FRE | St. Assise, France | |
| 16.50 | 18,170 | CGA | Drummondville, Quebec, Canada | Telephone to England. Canadian Marconi Co. |
| 16.52 | 18,150 | PMC | Bandoeng, Java | |
| 16.54 | 18,130 | GBW | Rugby, England | |
| 16.57 | 18,120 | GBK | Bodmin, England | |
| | | W9XAA | Chicago, Ill. | Testing, mornings. |
| 16.61 | 18,050 | KQJ | Bolinas, Calif. | |
| 16.70 | 17,950 | FZU | Tamatave, Madagascar | |
| 16.80 | 17,850 | PLF | Bandoeng, Java | ("Radio Malabar") |
| | | W2XAO | New Brunswick, N. J. | |
| 16.82 | 17,830 | PCV | Kootwijk, Holland | 3 to 9 a.m. |
| 16.87 | 17,780 | W8XK | Pittsburgh, Pa. | |
| 16.90 | 17,750 | HSIPJ | Bangkok, Siam | 7-9:30 a.m., 1-3 p.m. Sundays. |
| 17.00 | 17,610 | Ship Phones to Shore: | | WSBN, "Leviathan"; GFVW, "Majestic"; GLSQ, "Olympic"; GDLJ, "Homer"; GMJQ, "Beltenland"; work on this and higher channels. |
| 17.25 | 17,380 | JIAA | Tokyo, Japan | |
| 17.34 | 17,300 | W2XK | Schenectady, N. Y. | Tues., Thurs., Sat. 12 to 5 p.m. General Electric Co. |
| | | W8XL | Dayton, Ohio | |
| | | W6XAJ | Oakland, Calif. | |
| | | W7XA | Portland, Ore. | |
| | | W7XC | Seattle, Wash. | |
| | | W2XCU | Ampere, N. J. | |
| | | W9XL | Anoka, Minn. | and other experimental stations. |
| | | VE9AD | Glace Bay, N. S., Canada | |
| 17.52 | 17,110 | W00 | Deal, N. J. | Transatlantic phone. |
| | | W2XDO | Ocean Gate, N. J. | A. T. & T. Co. |
| 17.55 | 17,080 | GBG | Rugby, England | |
| 18.37 | 16,320 | VLK | Sydney, Australia | Phone to England. |
| 18.40 | 16,300 | PCL | Kootwijk, Holland | Works with Bandoeng from 7 a.m. Netherland State Telegraphs. |
| | | WLO | Lawrence, N. J. | |
| 18.50 | 16,200 | FZR | Saigon, Indo-China | |
| 18.56 | 16,150 | GBX | Rugby, England | |
| 18.68 | 16,060 | NAA | Arlington, Va. | Time signals, 11:57 to noon. |
| 18.80 | 15,950 | PLG | Bandoeng, Java | Afternoons. |
| 18.90 | 15,860 | FTK | St. Assise, France | Telephony. |
| 18.93 | 15,760 | JIAA | Tokyo, Japan | Up to 10 a.m. Beam transmitter. |
| 19.50 | 15,375 | F8BZ | French phone | to ships. |

All Schedules Eastern Standard Time: Add 5 Hours for Greenwich Mean Time.

| Meters | Kilo-cycles | Station Name | Location | Notes |
|-------------|---------------|-------------------|--------------------------------|--|
| 19.56 | 15,340 | W2XAD | Schenectady, N. Y. | Broadcasts 3-6 p.m.; Sun., 1-6 p.m.; relaying WGY. |
| 19.60 | 15,300 | OXY | Lyngby, Denmark | Experimental. |
| 19.63 | 15,280 | W2XE | Jamaica, N. Y. | |
| 19.66 | 15,250 | W2XAL | New York, N. Y. | |
| | | W6XAL | Westminster, Calif. | |
| 19.72 | 15,210 | W8XK | (KDKA), Pittsburgh, Pa. | Tues., Thurs., Sat., Sun., 8 a.m. to noon. |
| 19.83 | 15,120 | HVJI | Vatican City (Rome, Italy) | 4-5:30 a.m. |
| 19.99 | 15,000 | CM6XJ | Central Tuinucu, Cuba | |
| | | LSJ | Monte Grande, Argentina | |
| 20.50 | 14,620 | WMI | Deal, N. J. | |
| | | XOA | Mexico City | 2:30-3 p.m. |
| 20.70 | 14,480 | W8XK | East Pittsburgh, Pa. | |
| | | GBW | Rugby, England | |
| | | WNC | Deal, N. J. | |
| 20.80 | 14,420 | VPD | Suva, Fiji Islands | |
| 20.90 | 14,310 | G2NM | Sonning-on-Thames, England | Sundays, 1:30-3 p.m. |
| 20.97-21.26 | 14,300-14,100 | Amateur Telephony | | |
| 21.17 | 14,150 | KKZ | Bolinas, Calif. | |
| 21.50 | 13,910 | | Bucharest, Roumania | 2-5 p.m., Wed., Sat. |
| 21.59 | 13,890 | | Mombasa, East Africa | |
| 22.20 | 13,500 | | Vienna, Austria | |
| 22.38 | 13,400 | WND | Deal Beach, N. J. | Transatlantic telephony. |
| 22.68 | 13,220 | Ship Phones | | |
| 23.00 | 13,013 | OBE | La Punta, Peru | Time signals 2 p.m. |
| 23.35 | 12,850 | W2XO | Schenectady, N. Y. | Antipodal program 9 p.m. Mon. to 3 a.m. Tues. Noon to 5 p.m. on Tues., Thurs. and Sat. General Electric Co. |
| | | W2XCU | Ampere, N. J. | |
| | | W00 | Deal, N. J. | |
| | | W2XDO | Ocean Gate, N. J. | |
| | | W9XL | Anoka, Minn. | and other experimental relay broadcasters. |
| 23.38 | 12,820 | | Rabat, Morocco | Sun., 7:30-9 a.m. Daily 5-7 a.m. Telephony. |
| 23.16 | 12,780 | GBC | Rugby, England | |
| 23.90 | 12,550 | VBS | Glace Bay, Nova Scotia, Canada | |
| 24.11 | 12,280 | GBU | Rugby, England | |
| 24.46 | 12,250 | FTN | St. Assise (Paris), France | Works Buenos Aires, Indo-China and Java. On 9 a.m. to 1 p.m. and other hours. |
| | | KIXR | Manila, P. I. | |
| | | GBS | Rugby, England | |
| 24.63 | 12,280 | Airplane | | |
| 24.68 | 12,150 | GBS | Rugby, England | Transatlantic phone to Deal, N. J. (New York). |
| | | FQO, FQE | St. Assise, France | |
| 24.80 | 12,090 | | Tokyo, Japan | 5-8 a.m. |
| 24.80 | 12,090 | | Trieste, Italy | |
| 24.89 | 12,045 | NAA | Arlington, Va. | Time signals, 11:57 to noon. |
| | | NSS | Annapolis, Md. | Time signals, 9:57-10 p.m. |
| 24.98 | 12,000 | FZG | Saigon, Indo-China | Time signals, 2-2:05 p.m. |
| | | | Oporto, Portugal | |
| 25.10 | 11,945 | KKQ | Bolinas, Calif. | |
| 25.24 | 11,880 | W8XK | (KDKA), Pittsburgh, Pa. | Tues., Thurs., Sat., Sun., 11 a.m.-4 p.m., and Sat. night Arctic programs. Television, Mon. and Fri., 2:30 p.m., 60 lines, 1200 r.p.m. |
| | | W9XF | Chicago (WENR) | |
| | | W2XAL | New York (WRNY) | |
| 25.26 | 11,870 | VUC | Calcutta, India | 9:45-10:45 p.m.; 8-9 a.m. |
| 25.30 | 11,860 | VE9CA | Calgary, Alta. | |
| 25.34 | 11,840 | W2XE | Jamaica, New York (WABC) | |
| | | W9XAA | Chicago, Ill. | 7-8 a.m., 1-2, 4-5:30, 6-7:30 p.m. |
| 25.36 | 11,820 | KIXR | Manila, P. I. | 5-6 p.m., 11:15 a.m., 12:15 p.m., 2-4 a.m., and (except Monday) 5-10 a.m. |
| 25.42 | 11,800 | UOR2 | Vienna, Austria | Tues., 9-11 a.m.; Wed., 5-7 p.m.; Thurs., 5-7 a.m. |
| | | W2XAL | New York | |
| | | W9XF | Chicago | |
| | | PK6KZ | Macassar, Celebes | |
| | | I2RO | Rome, Italy | (Various wavelengths). |
| 25.47 | 11,780 | VE9DR | Drummondville, Quebec, Canada | |
| 25.50 | 11,760 | XDA | Mexico City | |
| 25.53 | 11,750 | G5SW | Chelmsford, England | 6:30-7:30 a.m. and 2-7 p.m. except Saturdays and Sundays. |
| 25.58 | 11,720 | CJRX | Middlechurch, Man., Canada | |

(NOTE: This list is compiled from many sources, all of which are not in agreement, and which show greater or less discrepancies; in view of the fact that most schedules and many wavelengths are still in an experimental stage; that daylight time introduces confusion and that wavelengths are calculated differently in many schedules. In addition to this, one experimental station may operate on any of several wavelengths which are assigned to a group of stations in common. We shall be glad to receive later and more accurate information from broadcasters and other transmitting organizations, and from listeners who have authentic information as to calls, exact wavelengths and schedules. We cannot undertake to answer readers who inquire as to the identity of unknown stations heard, as that is a matter of guesswork; in addition to this, the harmonics of many local long-wave stations can be heard in a short-wave receiver.—EDITOR.)

| Meters | Kilo-cycles | Station Name | Location | Notes |
|--------|-------------|--------------|---------------------------------|---|
| 25.68 | 11,670 | K10 | Kahulu, Hawaii | |
| 26.00 | 11,530 | CGA | Drummondville, Canada | |
| 26.10 | 11,490 | GBK | Bodmin, England | |
| 26.20 | 11,440 | KIXR | Manila, P. I. | 11:15-12:15 p.m., 2-4 a.m., 5-10 a.m. |
| 26.22 | 11,435 | DHC | Nauen, Germany | |
| 26.60 | 11,280 | ONIBDK | Brussels, Belgium | |
| 26.70 | 11,230 | IBDK | S.S. "Elettra," Marconi's yacht | |
| 27.30 | 10,980 | ZLW | Wellington, N. Z. | Tests 3-8 a.m. |
| 27.75 | 10,800 | GBX | Rugby, England | |
| 28.00 | 10,710 | CTIBO | Lisbon, Portugal | |
| | | | Casablanca, Morocco | |
| 28.20 | 10,630 | PLR | Bandoeng, Java | Works with Holland and France weekdays from 7 a.m.; sometimes after 9:30. |
| 28.44 | 10,540 | WLO | Lawrence, N. J. | |
| 28.50 | 10,510 | RDRL | Leningrad, U.S.S.R. (Russia) | |
| | | VLK | Sydney, Australia | 1-7 a.m. |
| 28.80 | 10,410 | PDK | Kootwijk, Holland | |
| | | KEZ | Bolinas, Calif. | |
| 28.86 | 10,390 | GBX | Rugby, England | |
| 28.97 | 10,350 | LSX | Buenos Aires, Argentina | 7-9 p.m. Transradio Internacional, San Martin 329, Buenos Aires. |
| 29.00 | 10,340 | | Paris, France | 1:30-3 p.m. daily; 9 a.m. Sundays. |
| 29.50 | 10,160 | HS2PJ | Bangkok, Siam | Sun., Tues., Fri., 8-11 p.m. |
| 29.54 | 10,150 | DIS | Nauen, Germany | Press (code) daily; 6 p.m., Spanish; 7 p.m., English; 7:50 p.m., German; 2:30 p.m., English; 5 p.m., German. Sundays: 6 p.m., Spanish; 7:50 p.m., German; 9:30 p.m., Spanish. |
| 29.98 | 10,000 | CM2LA | Havana, Cuba | |
| | | | Belgrade, Jugoslavia | Monday 3-4 p.m. |
| 30.15 | 9,940 | GBU | Rugby, England | |
| 30.20 | 9,930 | W2XU | Long Island City, New York | |
| | | | Posen, Poland | |
| 30.30 | 9,890 | LSN | Buenos Aires, phone to Europe | |
| | | EAQ | Madrid, Spain | |
| 30.50 | 9,830 | TIANRH | Heredia, Costa Rica | 10-11 p.m. Amando Cespedes Maria, Apartado 40. |
| 30.57 | 9,810 | LSOR | Buenos Aires, Argentina | |
| 30.61 | 9,790 | GBW | Rugby, England | |
| 30.75 | 9,750 | | Agen, France | Tues. and Fri., 3 to 4:15 p.m. |
| | | WNC | Deal, N. J. | |
| 30.90 | 9,700 | WMI | Deal, N. J. | |
| 31.10 | 9,640 | | Monte Grande, Argentina | works Nauen irregularly after 10:30 p.m. |
| | | VVB | Bombay, India | Testing. |
| 31.23 | 9,600 | LGN | Bergen, Norway | |
| 31.26 | 9,590 | PCJ | Hilversum (Eindhoven), Holland | Wed. 1-3 p.m., Thurs. 1-3, 6-10 p.m., Fri. 1-3, 7 p.m. Sat. 1 a.m. Philips Radio. |
| 31.30 | 9,580 | W3XAU | Byberry, Pa. | relays WCAU daily. |
| | | VK2ME | Sydney, Australia | |
| | | VPD | Suva, Fiji Islands | |
| | | KIXR | Manila, P. I. | |
| 31.33 | 9,570 | WIXAZ | Springfield, Mass. (WBZ) | 6 a.m.—10 p.m. daily. Westinghouse Elec. & Mfg. Co. |
| 31.36 | 9,560 | | Konigswusterhausen, Germany | 10 to 11 a.m., 11:30 a.m. to 2:30 p.m., and 3 to 7:30 or 8:30 p.m. Relays Berlin. |
| | | NAA | Arlington, Va. | |
| | | KIXR | Manila, P. I. | |
| | | ZL2XX | Wellington, New Zealand | |
| 31.48 | 9,530 | W2XAF | Schenectady, New York | 5-11 p.m. |
| | | W9XA | Denver, Colorado | Relays KOA. |
| | | | Helsingfors, Finland | |
| 31.56 | 9,500 | OZ7RL | Copenhagen, Denmark | Around 7 p.m. |
| | | VK3ME | Melbourne, Australia | Saturdays 5-6:30 a.m. Amalgamated Wireless, 47 York St., Sydney, Australia. |
| | | OXY | Lyngby, Denmark | 2-6:30 p.m. |
| 31.70 | | | | |

Short-Wave Stations — When to Listen

(Continued from opposite page)

Table listing radio stations with columns for Meters, Kilo-cycles, and station details including call letters and broadcast times.

Table listing radio stations with columns for Meters, Kilo-cycles, and station details including call letters and broadcast times.

Table listing radio stations with columns for Meters, Kilo-cycles, and station details including call letters and broadcast times.

'HAMS' PLEASE NOTE
At the suggestion of one of our readers, beginning with the next issue, we will publish advertisements of radio experimenters, Hams, and all others who wish to swap or exchange used radio material.

(Continued on page 63)

Television

Wallace Blackford, Chicago, Ill., asks:

Q. (1) In regard to the television receiver, P. 381 (Feb.-March issue), can R4 be a plain two-terminal resistor instead of a potentiometer?

A. (1) Yes, this can be employed as a straight resistor in series with the screen

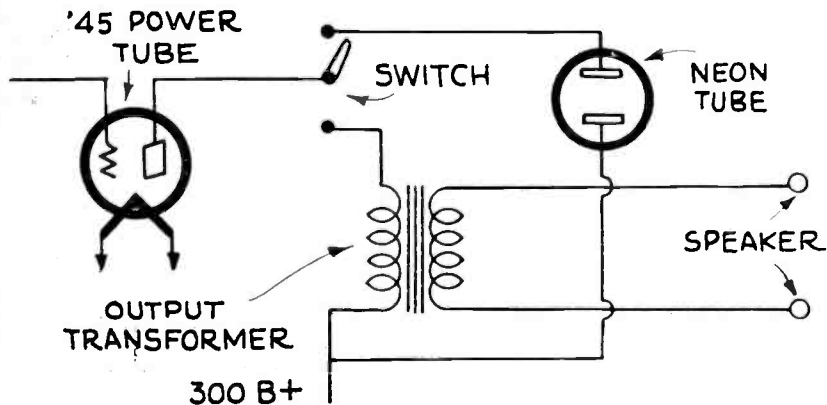

Diagram at the left shows how an output transformer may be used in place of a choke-condenser arrangement for connecting the loudspeaker and neon tube of a television receiver set. This is in answer to Mr. Blackford's query.

grids. It should, however, have a value of 100,000 ohms when used in this manner.

Q. (2) Would copper screen provide suitable shielding for the tubes and coils?

A. (2) Copper screen may be effectively used to shield the tubes against capacitive feedback, but solid shielding is necessary for the coils.

Q. (3) Can an output transformer be used in place of a choke-condenser arrangement for the loud speaker?

A. (3) Yes. A diagram showing the use of a transformer is shown in these columns.

Converting Receiver for All Bands

Joseph Veasey, Philadelphia, Pa., would like to know:

Q. (1) How to change the television receiver in the Feb.-March issue to tune to all the short-wave bands as well as the television band?

A. (1) This receiver was designed ONLY for television reception and not as an all-service set. You are referred to other articles in this and past issues of SHORT WAVE CRAFT for details on how to build receivers to cover all the short wavebands.

Oscillation Indicator

C. P. Chowna, Bombay, India, wants to know:

Q. 1. How to connect a milliammeter in the plate circuit of the detector, in order to indicate when the tube breaks into oscillation?

A. 1. The diagram for connecting the milliammeter into circuit is given here. The meter should have a range of 0 to 3

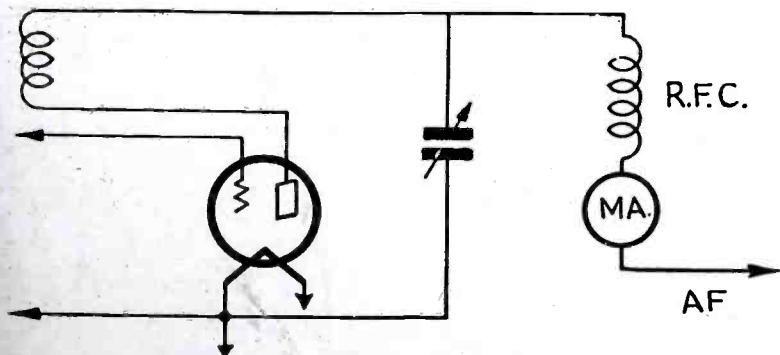

How to connect a milliammeter in the plate circuit of a detector to indicate when the tube breaks into oscillation.

or 0 to 5 milliamperes. When the tube breaks into oscillation, the reading will decrease.

Cage Antenna Dimensions

C. L. Alderman, Wauzeka, Wis., wants to know:

Q. (1) The dimensions of a cage an-

tenna for use with the phone transmitter as described in the Feb.-March issue, P. 372.

A. (1) Cut four wires each 100 feet long. No. 12 or 14 enamelled wire should be used. The cage hoops may be made from No. 6 copper wire, a diameter of 6 inches being sufficient. A similar counterpoise should also be made up. The antenna should be erected as high as possible, and the counterpoise about 6 to 8 feet from the ground.

Q. (3) What should be the voltage of a power transformer for use with 2-'24's, 1-'27 and 2-'71A's?

A. (3) The high-voltage winding should give about 300 volts on each side of center tap.

S.W. Super-Het

Charles Edwards, Wichita Falls, Texas, wants to know:

Q. (1) How to connect an untuned R.F. stage ahead of the first detector of the superhet described on P. 150 (Aug.-Sept. issue)?

A. (1) The circuit is shown in these columns. The primaries are removed from the first-detector coils and the output of the R.F. stage is connected to the grid of the detector. The R.F. chokes are of the short-wave type. R has a resistance of 400 to 500 ohms. The bypass condensers C are of the "postage stamp" type and have a capacity of .006-mf. Condenser C1, used to couple the R.F. to the detector, has a capacity of .0001-mf.

Q. (2) What is meant by winding the I.F. transformer primaries in a "hank"?

A. (2) This means winding the primaries on a form haphazard fashion; when finished, the coils may be slipped off the form and tied with string in two or three places. Collodion may be used to hold the primaries in place in the finished I.F. transformer.

Q. (3) Can the oscillator and the first-

Diagram at right covers Mr. Edward's question as to how to connect an untuned R.F. amplifier stage ahead of the first detector, of the superheterodyne described in a recent number of this magazine.

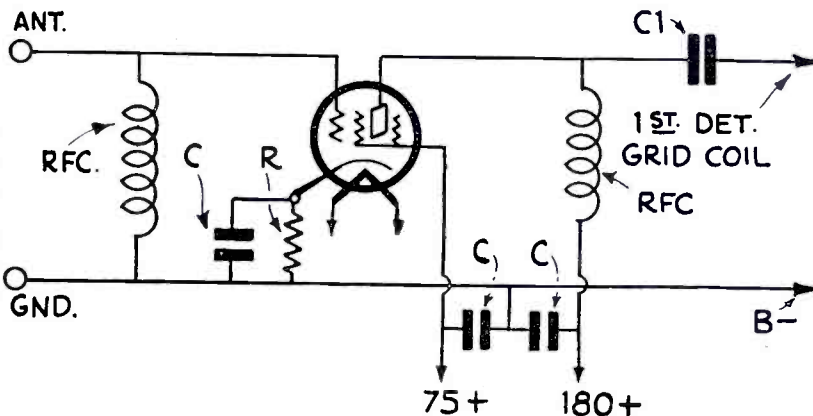

Plate Voltage Values

Joseph E. Ferrecki, Chicago, Ill., asks the following:

Q. (1) Will 500 volts on the plates of 2-'10 tubes be high enough to provide oscillation?

A. (1) Yes, even much lower voltages can be used.

Q. (2) Is 150 mills too high for plate current to these tubes?

A. (2) 150 mills is too high; 100 to 120 mills being normal when the tubes are oscillating.

detector tuning condensers be ganged?

A. (3) No.

Television Receiver

James Dunbar, Highland Creek, Ontario, Canada, desires the following information:

Q. (1) Is it practical to operate the television receiver, as described on P. 381 (Feb.-March issue) on batteries?

A. (1) The television set in question can be operated from batteries but I would not say that this is exactly practical, because of the high current drain. This receiver could incorporate a '71A power audio stage in place of the '45 and use a type of neon tube having a striking voltage of 100 and a current rating of 5 to 20 milliamperes. The R.F., the detector, and first audio stages would, of course, employ D.C. tubes.

Q. (2) Can a neon tube and a speaker be used together, to bring in both pictures and sound at the same time?

A. (2) No. Separate receivers and amplifiers must be used, for speaker and neon.

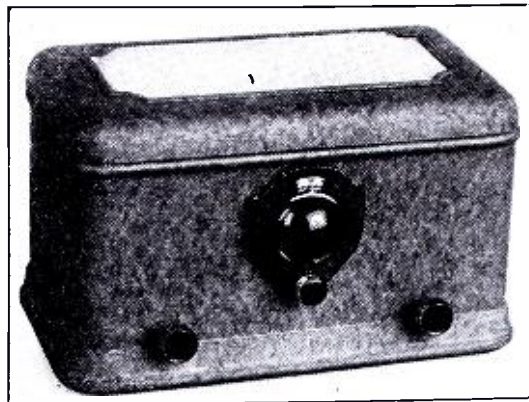

Left: Neat appearance of the super-converter that brings in short waves on your broadcast receiver.

Right: Hook-up of parts in the Walker super-converter.

The WALKER Super-Converter

THE super-heterodyne converter gives every indication of providing the ultimate in efficient short-wave reception. Every short-wave radio fan already possesses a broadcast band receiver of some sort. Now remains the means of converting the broadcast band receiver, so that short-wave stations throughout the world may be tuned in, with simplicity and sensitivity the prime factors.

The Walker Super-Converter—a handy and efficient means of converting your present broadcast band receiver to tune in short-wave programs and police calls, over the band from 15 to 200 meters. This converter, which depends upon the electric-light socket for its source of power, may be used with all types of receivers, whether A.C., or battery type, and including superheterodynes.

The principle of converting your present T.R.F. or neutrodyne receiver into a short-wave superheterodyne is quite simple. All receivers have an R.F. "tuning circuit", which covers the broadcast band of 200-550 meters (equivalent to 1,500-500 kilocycles). In addition, there is the audio amplifier circuit, which

greatly increases the volume of the signal detected and amplified at radio frequency by the tuning circuit. In all superheterodyne receivers there are, in addition to these circuits possessed by T.R.F. or neutrodyne receivers, the oscillator and first-detector circuits. The Walker Super-Converter contains an oscillator and a first detector, as well as a stage of screen-grid radio-frequency amplification ahead of the detector to further boost the volume. The signal is picked up by the converter and passed on to the receiver for additional amplification; thereby utilizing each circuit of the receiver and making unnecessary the purchase of an extra speaker or the erection of a special antenna. *All tuning is done with the simplified controls of the converter.*

The receiver is not disturbed, since there is no need to "plug in" to furnish the power necessary to operate a converter. A connection is made from the converter directly to the antenna post

of the receiver. There is no overloading of the receiver's power supply; since this new converter draws its power directly from the light socket. There can be no possible damage to the receiver.

Regeneration provides a degree of sensitivity and selectivity otherwise unattainable; it has been credited with the efficiency of an additional tube. Where is there a "dyed in the wool" short-wave fan who does not insist upon regeneration? A stage of screen-grid, radio-frequency amplification, ahead of the regenerative detector, not only insures greater volume, but also provides for the use of any length of antenna; in addition, it prevents radiation, which might disturb your neighbor's short-wave set. The oscillator and the detector tuning condensers are ganged and provided with a fine vernier dial for sharp tuning. A small midget condenser, connected in parallel with the oscillator condenser, permits obtaining exact resonance at all wavelengths.

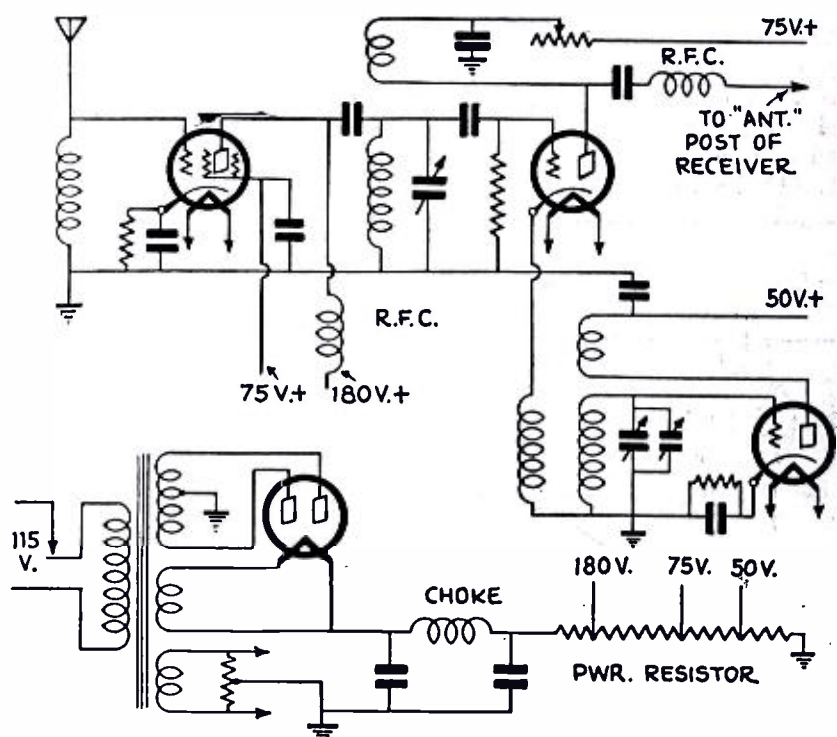

Dial Spreader For Amateur Bands

LET us suppose that, for the 40- and 80-meter bands, an ample spread of the tuning response is obtained over the tuning dial. Yet, when the 20-meter coils are plugged into the coil sockets, the whole band might be bunched together over about a maximum of four dial divisions. And this in spite of the fact that sound engineering principles had entered into the design of the receiver (as in the case of the National "SW-5" Thrill Box, where not only 270-degree straight-frequency-line tuning condensers were used, but also a special vernier dial with a scale of large diameter and a vernier of high reduction ratio.)

It was, therefore, in an effort to develop some ready means for wide band-spreading at any frequency, without impairing the "general purpose" qualities of the "SW-5," that the special "band-

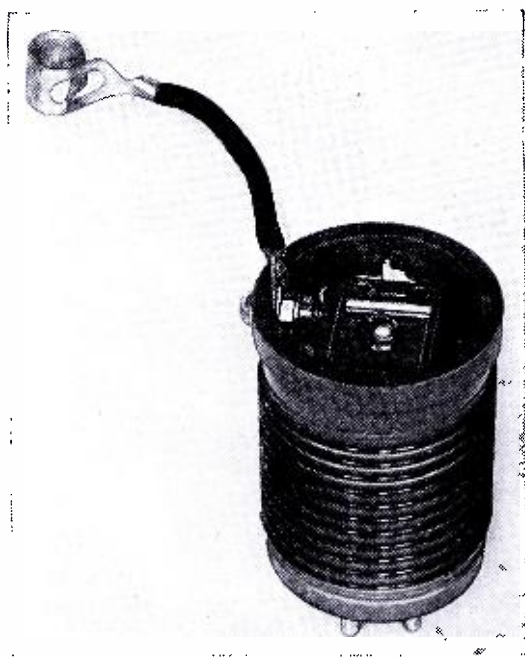

spread coils" were developed. These new coils are merely "plugged in," in the same manner as the standard coils, and without making any changes in the receiver itself.

The result, in the case of the 20- and 40-meter amateur bands, is a 50-division spread located right in the center of the dial, thus leaving an equal band for overlap at each end.

In general appearance (as will be seen from the accompanying photographs) the new band-spread coil differs from the conventional S.W. coil only in that there comes out of the top a lead for clipping directly to the cap of the screen-grid tube, in place of the lead and clip built into the receiver. Inside the coil form, however, will be found a small grid leak and grid condensers, as well as an adjustable low-capacity trimmer condenser.

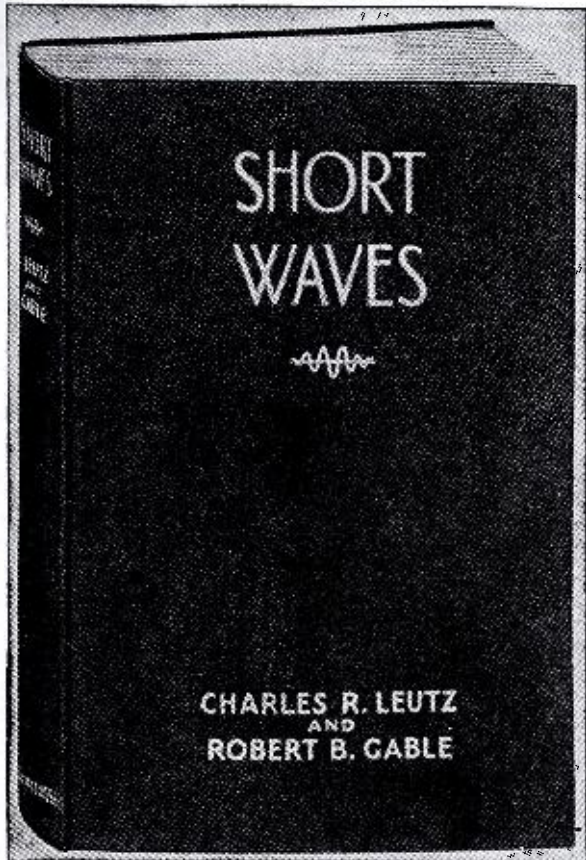

Mr. Charles R. Leutz, April 6, 1931.
 C. R. Leutz, Inc.
 Altoona, Penna.

Dear Mr. Leutz:
 Your letter of April 1st has just been referred to me, and in reply I willingly say that your latest book, "Short Waves" by Leutz and Gable, contains a source of information that everyone interested in the development of short waves should not only read, but digest thoroughly.

This book besides its practical and helpful information on transmitters and receivers for short wave broadcast, shows conclusively the unlimited possibilities of advanced radio design and its application to bring about more rapidly Television.

"Short Waves" has been enlightening to me, and truthfully must say that very shortly, I plan to read it again for its valuable contents.

Very truly yours,
 SHORT WAVE CRAFT,
 H. W. Secor,
 Managing Editor.

H. W. Secor
 bn
 Enc.

SHORT WAVES

By Charles R. Leutz and Robert B. Gable

RADIO experimenters and engineers have long sought an authoritative text on short waves which includes its history and chronological development. In "SHORT WAVES", by Leutz and Gable, both well-known radio engineers, the material gathered explains thoroughly the progressive stages of short waves. From the early days of the pioneer and amateur, with the experiments of Maxwell, Marconi, Hertz, Lodge, Pickard and others, right down to present-day methods of ultra-short waves (medical and surgical applications)—still farther, with clarifying explanations of short waves in the art of television and superheterodyne construction.

"SHORT WAVES" is broad and instructive—it is replete with photographs and diagrams which facilitates reading and understanding. Such important chapters tend to make this book everlastingly useful to everyone in radio.

The chapters, ten in all, cover:

HISTORICAL REVIEW
 SHORT WAVE PROPAGATION
 COMMERCIAL RADIO TELEPHONY AND TELEGRAPHY
 SHIP-TO-SHORE TELEPHONY
 DIRECTIONAL ANTENNAE

TELEVISION
 AIRCRAFT RADIO EQUIPMENT
 SHORT WAVE BROADCAST RECEIVERS
 ULTRA-SHORT WAVES (MEDICAL AND SURGICAL APPLICATIONS)
 AMATEUR SHORT WAVE EQUIPMENT

SHORT WAVES

384 Pages. 250 Illustrations

Size 6 x 9 inches, fully bound

Price \$3.00

C. R. LEUTZ, Inc.,
 Altoona, Penna.

I enclose herewith \$3.00 (check or money order preferred), for which please send me postpaid One Copy of SHORT WAVES by Leutz and Gable.

Name

Address

City..... State.....

If SHORT WAVES, by Leutz and Gable, is not obtainable at your booksellers, simply clip the coupon at the right and mail with your remittance.

C. R. Leutz, Inc. are also manufacturers of high grade receivers. We specialize in making sets to specifications. Write for our literature.

Please mention SHORT WAVE CRAFT when writing to advertisers

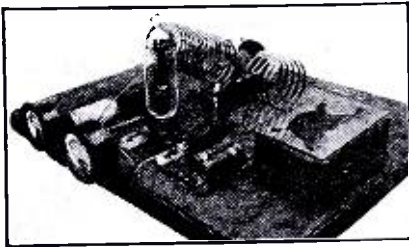

DELFT Short-Wave Transmitter Kit, \$8.95

See previous issues of S. W. C. for Transmitter Kit supplies for all parts to build set shown, except meters and baseboard. Will operate with receiving tubes. Battery or light socket. Full instructions. Transmits 1,000 miles or more. Can be used with phone (attachment \$1 extra). Complete Kit, \$8.95 postpaid.

DELFT Short-Wave R.F. Amplifier Kits

Screen-Grid R-F Amplifier Kits supply all parts. Add ahead of your S. W. receiver or any converter. Greater distance. Full instructions. Uses power from your present set. Battery Operation (2-volt or type '22 tubes): One-Tube Kit, \$5.95; Two-Tube, \$7.95. Light Socket Operation (type '24 tubes): One-Tube Kit, \$7.45; Two-Tube, \$9.45. Fil. transformer, \$3. Less Tubes.



DELFT Short-Wave Portable Receiver

Absolutely the latest design in every particular. Nothing like it. Photo shows hinged front door removed. This sturdy set can be used for all portable uses in autos, planes, yachts, etc. Receives 1,000 miles or more on 10 ft. aerial or shorter; 3,000 or more on longer wire. Sturdy but light in weight. Complete in itself; entirely enclosed. Phones and extra coils slip inside. Special, easy tuning over whole short-wave field. Uses two new 2-volt tubes. Measures only 8 by 18 inches; depth 5 inches. Uses tube-base coils (1 inch diameter); plug in at top of case to change to different wave bands. Compact but efficient. Gets code or music. Kit includes ALL parts, knocked down case (everything to the last nut), full, simplified assembly instructions and a whole set of good plug-in coils so you can get any short wave. Complete Kit \$18 (less tubes, batteries—two special, portable, 45-volt size—and phones). Tubes \$1.80 each, phones \$1.75 pair. Kit shipped absolutely complete, \$27.00. Portable receiver shipped complete (assembled, tested, and nicely finished), \$32.00 (with carrying handle and straps)!!! Ask about our portable phone transmitter to match above set. Tell your friends.

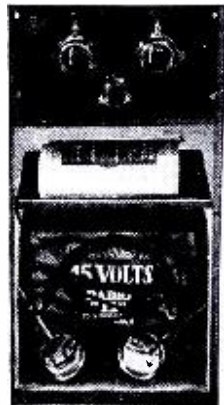

TUBE BASE PLUG-IN COILS!!—There is CONSIDERABLE difference between different makes of coils! We test ours in our short wave sets. (Our tube base plug-in coils have finger handles to protect the windings.) Fit 4-prong socket. For R-F amplifier use, 15 to 125 meters, using either a .0001, .00014 or .00015 condenser; set of 3 (have finger handles), \$1.35. Same kind coils but with tickler windings also (for detector), \$1.85.

Latest Natural-Tone Code-Practice Set, uses '99 tube, works on two dry cells, \$3.85 postpaid. Tube \$1.15. Complete Kit for building a short-wave adapter or converter, A.C. or D.C., less tube, \$5.95.

We sell DIRECT, have no agencies; that means LOW prices. Notice the postpaid items; the ACTUAL COST DELIVERED IS LOW. C.O.D. orders cheerfully sent. Easy to order (why let others run away with ALL the gravy?). Just send \$1 in stamps or a \$1 bill, write what you want, pay rest to postman when delivered. Send bills, small amounts in stamps; wrap well; register letter if necessary. Prompt Service!!! Ask about our used radio parts at one-tenth to one-fourth regular prices. All OK; little solder on lugs or slight scratches. Order an Experimenter's Surprise Package; contains \$10 worth of coils, condensers, etc. Price \$2. State your needs; if we have it, will put in package. Send Lists of Parts for prices, and a few stamps for postage on catalogs.

NOTICE the items that are sent postpaid; you save postage, collection and M.O. fees. We save you PLENTY on postage too, so the ACTUAL COST DELIVERED IS LOW! C. O. D. orders cheerfully sent; send \$1 in stamps, pay rest to postman.

ASK about our used radio parts. We can supply coils, fixed and variable condensers (all sizes), rheostats, sockets, transformers, posts, panels, etc., at prices ranging from 1/10 to 1/4 regular prices.

DELFT

Phone: Higate 0748

524 Fairbanks Avenue,
OAKLAND :: CALIFORNIA

SHORT - WAVE
RADIO
SPECIALISTS

Short Waves Outwit the Oyster

By S. R. WINTERS

(Continued from page 33)

detic Survey ships may thus continue their surveying operations off-shore in fog or haze; the combination of radio and sound charting their distance from the shore even when the latter is totally obscured. This is routine procedure on coasts of the Pacific Ocean.

How Oyster Interfered

However, when similar shore and ship installations were made on the coast of the Atlantic Ocean weird noises came out of the water and, half flippantly and half seriously, William E. Parker, Chief of the Division of Hydrography and

Topography, blamed the oyster as the source of interference with sound reception. Biologists accepted the challenge with a degree of seriousness. At the same time, the finger of indictment was pointed toward the 5-mile underwater wire as a source of induction interference. The real source of the trouble may never be known; but the method had to be modified to meet the peculiar conditions on the Atlantic Ocean. And it is this modification that has, at least experimentally, outwitted the oyster and line-induction interference.

Microphone Submerged 90 Feet

Instead of shore stations on land they are situated on water, as paradoxical as this may seem. The radio and sound instruments comprise a floating station—the equipment being installed on a launch and moored out to sea; present experiments being undertaken off the Virginia coast. The hydrophone or underwater microphone is submerged in ninety feet of water and it is this relatively great depth at which the sound equipment is installed that the problem is approaching a solution.

"Subaqueous sound waves," points out Mr. Parker, "do not pass readily over shoals. In fact, a shoal will cast a shadow, just as an intervening object in the path of light will reflect a shadow. Sound will travel in shallow water, but

P. C. J.

HOLLAND'S FAMOUS
SHORT-WAVE STATION
Photos and Description in Next Issue

the distance which it covers decreases very greatly."

Rôle of Short Waves

A short-wave radio receiving set is used in this radio-acoustic method of ranging; having the advantage of consuming little power and, therefore, can be operated with batteries. The launch which serves as the floating station is about 60 feet long and of ancient vintage—having been an old navy ferryboat at Portsmouth, New Hampshire. The new radio-acoustic ranging has been heard for a distance of 76 miles; whereas 30 miles was the maximum range of the ship-to-shore system when applied in the Atlantic Ocean.

How Radio-Sound Surveying Is Carried Out

The modified plan of procedure operates in this wise: First, determine the position of the surveying ship, close to shore, with reference to the shore. Then the surveying ship determines its distance from the floating station by firing a bomb. After the surveying vessel has determined from two different positions, two distances to the floating station, the position of the latter will be known by the intersection of the two arcs, swung from the two positions of the surveying ship.

A Single-Control Short Wave Receiver

By R. WILLIAM TANNER

(Continued from page 25)

in the R.F. stage and should be especially designed for short-wave work.

Audio Amplifier

The detector is resistance coupled to the '27 first audio stage. Both the plate and the grid resistors, R6 and R7, have a value of 500,000 ohms. Bias for the '27 is obtained from a 2,000-ohm resistor R8 in the cathode lead.

A novel coupling unit is employed between the two stages. The primary of an output transformer is connected in the plate circuit of the '27, and acts as an audio choke. The secondary goes to an open-circuit telephone jack for head-phone use. Any type of output transformer will not do; it must be one designed for tubes with a plate impedance of 5,000 to 10,000 ohms. Both of the coupling condensers C6 should have a capacity of from .006- to .01-mf. The '45 grid-leak resistor R9 may be as high as 0.25-megohm; but better tone quality will be obtained with a lower value. The power tube receives its bias from a 1,600-ohm resistor R10. All by-pass condensers C5 have a capacity of 1-mf. The speaker filter consists of a 30-henry choke A.F.C. and a 2-mf. 600-volt condenser C7.

Mounting and Wiring

The parts are laid out on a ½-inch wooden baseboard, approximately 17" long by 10" wide, in accordance with the diagram in Fig. 3. A pair of sub-panel brackets, one inch high, are fastened to the under side, to provide space for the R.F. chokes, by-pass condensers, etc. The controls are mounted on a 7 x 18-inch metal panel with the tuning dial in the center; the volume control at the left and the regeneration condenser at the right.

The detector tuning condenser is first attached to the panel, its regular shaft being replaced with another; 7" to 8" long, depending upon the dimensions of the condensers. This shaft has to pass through the detector shield box; so considerable care should be taken in locating the holes. Determine the exact distance from the baseboard to the center of the shaft, which will be the height from the bottom of the shield to drill the holes. It is a rather difficult job to drill a ¼-inch hole in thin copper; therefore use a small drill and then ream to the required size. Nearly all condensers are equipped with mounting feet; so, if the condenser on the panel is mounted to rest on the baseboard, no bracket will be needed for the R.F. condenser.

To conserve space, the box shields must be rather small in size. Silver-Marshall "Type 638" copper shields with removable tops are ideal, being only 5½ inches high, 4½ inches long and 2¾ inches wide. These allow sufficient space for the plug-in coils, tube, etc.

The R.F. shield is located directly behind the rear condenser; the buffer tube and antenna R.F. choke are just to the left of this. The audio amplifier is mounted at the right of the R.F. units. The coil sockets are raised 2 inches above the pans of the shields on brass pillars, threaded at both ends for 8/32 machine-screws. Space is then provided underneath the sockets for by-pass condensers.

When wiring, first measure two leads of exactly the same length, to connect the grid condensers to the control-grid terminals. Repeat the measuring process from the grid condenser to the "G" terminals on the coil sockets, from the tuning condensers to the coils and, in fact, all through the grid circuits. The wires from the coil-tap connection on the sockets to "P" on the R.F. and buffer sockets must also be of the same length. By doing this, stray capacities are made comparatively equal in both tuned circuits.

When the wiring is completed, the shields may be assembled and the condenser shaft inserted through the holes in the detector shield. The rotors on the two tuning condensers are then set at maximum capacity, and the set screws tightened.

Balancing the coils comes next. Plug in the two 20-meter coils and tune in a weak station (either code or radiophone will do) at about the center of the dial with the detector in a non-oscillating condition. Then, with a pencil or piece of wood, push the spaced turn on the detector grid coil closer towards the main winding until the signal is loudest. If the volume decreases, try the same procedure on the R.F. coil. When the exact points of resonance have been found, leave the coils in their sockets and paint the loose turns with collodion, to prevent later change in capacity. Do not remove the coils until thoroughly dry. Repeat this procedure with the 40-, 80- and 160-meter coils. It is plain to be seen that the trimmer-condenser method of balancing the two circuits would be useless with four sets of coils.

It will be found that, by varying the semi-variable resistor R5 in the detector's screen-grid lead, sensitivity can be increased; but do not go too far with this adjustment, or the tube will refuse to oscillate.

A suitable antenna for this receiver may be anything from 10 to 100 feet long; although above approximately 25 feet the gain is very slight.

Many modifications are possible, and the writer advises the constructor to try different ideas that may come to mind. Single control for short-wave receivers is bound to come; just as it did for use on the regular broadcast channels. This individual outfit is only a starter.

Get your

RADIO TRAINING

From America's
finest Radio School

THE man who really wants to become an expert in radio . . . who knows that the better his foundation, the better his chances . . . and who is willing to spend a year preparing himself . . . such a man will make no decision until he has read the complete story of RCA Institutes, Inc.

A Good Foundation Vital

Like other professions, radio rewards only those who excel. The poorly trained will never rise higher than the place in which they started. Others will climb step by step to positions of power in radio telephony . . . broadcasting . . . sound pictures . . . aviation radio . . . radio merchandising. And among these will be those who planned years in advance . . . studied, worked, stuck to it.

You are making your decision right now, how well you will fit yourself. So decide wisely. To be a graduate of RCA Institutes stamps you as a man who knows the real worth of a good foundation. As one who knows that a year of training now, under America's finest radio instructors, is the surest way to acquire the knowledge and skill you must have.

You Can Study At Home

You do not have to give up your present position to enjoy the benefits of RCA Institutes training. You may study at home in your spare time . . . or at any of our resident schools throughout the country. The Home Laboratory Training Course includes a complete set of radio equipment of the most modern design.

Send For Our Free Book

If you have read this far . . . you have already indicated that you are the type of man who should study radio. This may be the big turning point of your life. You will not rest until you have sent for our free book that tells you the complete story of what RCA Institutes offers you. Fill in and mail the coupon below right now. There is plenty of time for investigation . . . but no time for delay in getting all the vital facts.



RCA INSTITUTES, Inc.

RCA INSTITUTES, Inc.
Dept. SWC-6
75 Varick St., New York, N. Y.

Gentlemen: Please send me your FREE book which tells about your laboratory method of radio instruction at home.

Name.....
Address.....
.....
Occupation.....

Please mention SHORT WAVE CRAFT when writing to advertisers

Television Receiving Lamps for Practical and Experimental Use—

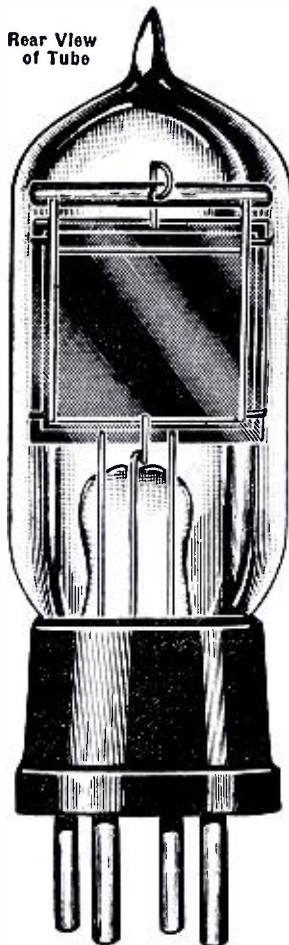

Rear View of Tube

RECENT television developments in the laboratory of a well-known company have opened this field for experimentation to advanced radio enthusiasts. The ARGCO Television Receiving Lamps have been manufactured expressly for the purpose of facilitating the demonstrations of experimenters and laboratory experts. The ARGCO Television Receiving Tubes have been designed to avoid high space charges, and at the same time, confine the light to the most useful portion of the cathode. Brilliant light spots usually found on the cathode and caused by high frequency current vibrations have been entirely eliminated in ARGCO Tubes by a special process which minimizes "sputtering" under the influence of the discharge. Rigid support of the elements is obtained by the use of sturdy glass rods.

TYPE TV-L is of small construction, 1 1/4 in. x 3 1/2 in. with cathode 1 in. square. List Price \$4.00

TYPE TV-S is a tubular lamp, 2 in. x 6 in. with cathode 1 1/2 in. square. List Price \$8.00

Cathode Ray Oscilloscope

The demand for this newer type of instrument has grown rapidly during the past year. The Type OS-1, a low voltage tube, has a filament consuming 5.5 amperes at 4 volts; while the anode potential requires 300-450 volts. Simplicity in design and ruggedness in construction enable this tube to be used for both amateur and industrial use. The operating transformer and stand may be supplied if desired.

Oscilloscope Tube List Price \$45.00
Stand, complete List Price 2.00

PHOTO-ELECTRIC CELLS

List Price \$15.00 and up

"A Brief Review of Photo Electricity and Its Application to Photo-Cells," 25c per copy. Postage free.

Manufacturers of

Photo-electric cells of all types—Television receiving lamps—Tungsten wire—Molybdenum wire—Film recording lamps—Stroboscopes—Rare gases—High voltage neon indicators—Carbon arc lamps—Therapeutic lamps—High powered neon lamps—Hydrogen and vacuum annealing ovens—Special tubes filled with rare gases—Special thermionic tubes—Special glass blowing—etc.

ARGCO

LABORATORIES, Inc.

150 West 22nd St. New York, N. Y.

Generous discounts on the above types to all manufacturers, distributors and dealers.

List of Parts

- RFC...R.F. chokes, short-wave type;
- C.....O.1-mf. by-pass condensers;
- C1.... .00014-mf. tuning condensers;
- C2.... .00025-mf. coupling condensers;
- C3.... .0005-mf. regeneration condenser, S.L.C. type;
- C4....1-mf. by-pass condenser;
- C5....1-mf. by-pass condensers;
- C6.... .01-mf. blocking condensers;
- C7....2-mf. speaker coupling condenser;
- R.....500-ohm R.F. biasing resistors;
- R1....2-megohm R.F. grid leak;
- R2....100,000-ohm variable volume-control resistor;
- R3....2-megohm detector grid leak;
- R4....10,000-ohm detector biasing resistor;
- R5....25,000-ohm screen-grid semi-variable resistor;
- R6....Detector plate resistor, 500,000 ohms;
- R7....500,000-ohm A.F. grid leak;
- R8....200-ohm A.F. biasing resistor;
- R9....100,000 to 25,000 ohms;
- R10...1,600-ohm A.F. biasing resistor;
- R11...60-ohm center-tapped filament resistors;
- AFC...30-Henry speaker filter;
- OT...Output transformer;
- J.....Open circuit jack.

Coil Table

| Band | L | L1 | L2 | Plate Taps |
|------|----|----|----|------------|
| 20 | 6 | 6 | 5 | 4 |
| 40 | 12 | 12 | 6 | 8 |
| 80 | 23 | 23 | 8 | 16 |
| 160 | 44 | 44 | 15 | 30 |

Portable S-W "Suitcase" Transmitter and Receiver

By R. WIGAND

(Continued from page 47)

angles to the dipole. Many pentodes require same voltages for screen grids and plates.

The coils L1 and L2 are wound on tube bases (of insulating material).

Coupling to the transmitter is accomplished as in Fig. 4, when L and C have the same dimensions as C1 and L2 in Fig. 1; while the incandescent lamp G1 must be suited to greater current strength (about 0.6 to 0.8 ampere). This form of antenna (see also Fig. 5) is under certain conditions more advantageous both for transmitting and for receiving than a dipole; since with it one more conveniently obtains greater effective height and radiation.

Switching from transmitting to receiving involves not only a possible changing over of the antenna, but also that of the filament supply; so that current may not be wasted. A simple change-over device for a dipole is shown in Fig. 8, and one for a Fuchs potential-coupled antenna in Fig. 9. To connect the batteries, it has proved practical to fasten the battery wires permanently to the sets.

For completeness, the specifications of the transmitter are as follows for the 20-meter band: L1, about 8 to 12 turns (to be tested out!); and L2 about 6; a 20-meter quartz crystal must be used.

Headquarters for Headsets

Even during the rapidly progressing years of radio there still remains need, for broadcast and testing purposes, experimental work and short wave reception, of headsets of precision manufacture and quality workmanship. The products presented below are made by the largest manufacturers of radio headsets in the world—products that have been recommended for years and years and need no introduction to the radio trade.

BRANDES and CANNON-BALL Products



BRANDES Matched Tone Headsets

Standard and reliable since 1908. Brandes Headsets have been used continually through these long years and have given remarkable service. They still occupy first position among headsets used throughout the world.

Superior, 2000 Ohms Resistance— \$4.50
List Price.....

CANNON-BALL Headsets

The popularity of Cannon Ball Headsets is a tribute to their high quality. Aluminum cases, double magnets and double poles. Quality built. Popular priced.

- Dixie, 1800 Ohms Resistance— \$2.25
List Price.....
- Senior, 2000 Ohms Resistance— \$3.00
List Price.....
- Master, 2200 Ohms Resistance— \$3.50
List Price.....

CANNON-BALL Single Phone

Used principally with Crystal Sets. Low in price and gives very satisfactory reproductions.

Dixie Single, with 4 1/2 ft. cord and braid headband. List Price..... \$1.50
Dixie Single, with 4 1/2 ft. cord without headband. List Price..... \$1.25

PANDORA Crystal Set

Selective and efficient. Receives broadcast reception loud and clear from stations within a radius of 25 miles. Of metal construction and enameled in various colors.

List price, with Crystal, \$2.50

Cannon & Miller Co., Inc.
Springwater New York

FOR BOOKS To Read During Your Spare Time

We suggest that you turn to Page 6 of this issue. On that page you will find many books to complete your hours of pleasure.

How Short Waves Cut Crime in Hungary

By DR. ANDRE SZENTIRMAY

(Continued from page 21)

main transmitter, and the antenna are arranged one over the other. For controlling the proper conditions of operation, four instruments are provided, which (for convenience in reading) are located in the antenna section. The number of switches, et cetera, is reduced to a minimum, so that only a few operations are necessary to adjust the transmitter to a desired wavelength. For changing from one form of operation to the other (sending telephony with or without tone) one has only to move a single switch.

The current supply for the transmitter comes from two transformers, one of which provides the energy for heating the tubes in the control and also the main transmitter, as well as the plate potential for the control apparatus. The second transformer provides the plate potential for the main transmitter. For increasing the stability of the transmitter the first mentioned transformer is provided with an automatic regulator governing the alternator.

Diesel Engine and Spare Generator

In case the city light line fails, a Diesel system is used, consisting of a Diesel engine and an AC generator.

Telephonic use of the transmitter is generally made from the sending room, but can also be accomplished from the receiving room. A special connection for telephonic use is placed there for the chief of police; so that in case of riots, etc., he can at any time give his orders directly, without using any intermediary. The keying of the transmitter can also be done at will from these various places.

Short-Wave Stations of the World

(Continued from page 55)

- 180.0 1,662—WMP, Framingham, Mass. (State Police).
—WRDS, Lansing, Mich. (State Police).
- 186.6 1,608—W9XAL, Chicago, Ill. (WMAC) and Aircraft Television.
—W2XY, Newark, N. J.
- 187.0 1,604—W2XCU, Wired Radio, Ampere, N. J.
—W2XCD, DeForest Radio Co., Passaic, N. J. 8-10 p.m., synchronized with television broadcasts.
—W1XAU, Boston, Mass.
—W3XJ, Wheaton, Md.
—W2XAD—W2XAF, Schenectady.
—W9XX, Cartersville, Mo.
—W5XN, Dallas, Texas.
—W2XDD, Portable.
—And other experimental stations.
—Ornskeldvik, Sweden.
- 187.9 1,596—WCF, New York, N. Y. (Fire Dept.)
—WKDT, Detroit, Mich. (Fire Dept.)
—K6KM, Beaumont, Texas.
—K6PA, Seattle, Wash., fire & police depts.
- 189.4 1,584—W10XAL, W10XAO, Portable (N. B. C.)
- 192.3 1,560—...Scheveningen, Holland.
- 194.3 1,544—W2XDA, New York.
- 196 1,530—...Karlskrona, Sweden.

The submarine "Nautilus," of the Trans-Arctic Submarine Expedition headed by Sir Hubert Wilkins, has been assigned the following wavelengths for relay broadcasting: 49.18 meters (6,100 kc.); 31.48 meters (9,530 kc.); 25.62 meters (11,710 kc.); 19.75 meters (15,160 kc.); and 16.87 meters (17,780 kc.).

GEORGE W. WALKER SUPER-CONVERTER

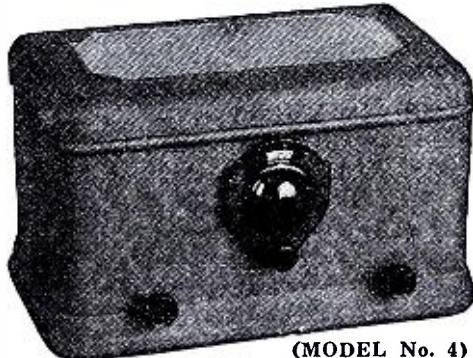

(MODEL No. 4)

WALKER SUPER-CONVERTER FEATURES

Four A.C. Tubes, including Screen Grid and No. 180 Rectifier. All A.C. operated.

TRULY SINGLE DIAL TUNING

No changing of coils for the popular Short-Wave Band.

Adaptable for use with either battery or A.C. receivers.

Attractive in appearance with its neat and compact two-toned moire finished

Convert Your
Present Radio Receiver
into a
Short-Wave Super-Heterodyne

✦ ✦

Listen to
Foreign Programs with
Pleasing Volume

metal cabinet, which measures but 7 x 7 x 12 inches long.

The Walker Converter represents the result of several years of experience in the design of Short-Wave equipment. Each device tested in actual operation at the factory, insuring uniform efficiency in performance.

COMPLETELY WIRED AND ASSEMBLED (Less Tubes)

\$65.00

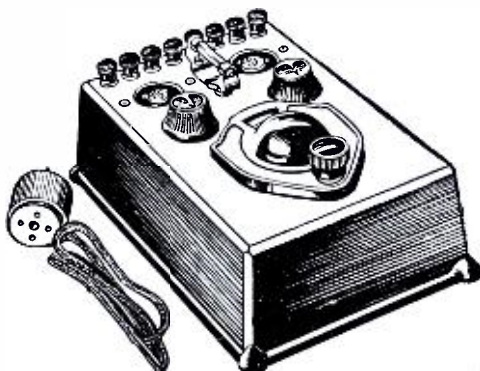

SHOWING No. '01 ADAPTER

Efficient reception of the entire wave band of 15 to 550 meters. Can be used with either A.C. or Battery receivers, or as an individual single tube receiver for short or long waves. Serves many purposes. Indestructible! Simple to operate—and inexpensive.

One of America's Pioneer Radio Manufacturers

THE WORKRITE RADIO CORP. 1809 East 30th Street
CLEVELAND - OHIO

FLEXI-UNIT

A FLEXIBLE RADIO DEVICE OF UNLIMITED APPLICATION

Short - Wave Receiver, Short - Wave Adapter, Regular Broadcast Tuner, R.F. Pre-Amplifier (Booster), Radio "Experimental" Unit, Oscillator and Wavetrap. USE THIS UNIT AHEAD OF YOUR SHORT-WAVE TUNER AS A R.F. BOOSTER.

Should your dealer be unable to serve you promptly — Mail your order direct to factory.

LIST PRICE
\$16.00
Including Coils
No. '01 Adapter Plug (Battery) . \$2.00
No. '27 Detector Plug (A.C. Set) 2.50
No. 27 R.F. Adapter Plug (A.C. Set) 3.00

Write for Free Literature — Liberal Discounts to Dealers and Service Men.

Do You Tune or Simply Fish for Short Wave Stations?

INTERNATIONAL SHORT WAVE RADIO NEWS will bring you up-to-date schedules of Short Wave Stations throughout the World for 12 months for only \$1.00, single copy, 10 cents. In addition INTERNATIONAL SHORT WAVE RADIO NEWS will bring you all the important "dope" of happenings in Short Wave Radio everywhere.

Order Your Copies Today
INTERNATIONAL
SHORT WAVE RADIO NEWS
Box 22, Boston, 30,
Jamaica Plain Station Massachusetts

VOLUME CONTROL GUIDE

By Engineering Staff of
CLAROSTAT

FREE to all those who write and mention this magazine.

Here is a real help for Service Men, Dealers and Experimenters. Sent without any charge or obligation. CLAROSTAT'S many years' experience manufacturing Volume Controls and other variable resistors has made it possible for us to compile this very useful and instructive piece of literature which should be handy to all those who work on radio and sound equipment. Write today. Be sure to mention this publication.

CLAROSTAT MFG. CO., Inc.
285 North 6th St. Brooklyn, N. Y.

Don't forget to read our unusual subscription offer on page 75

Please mention SHORT WAVE CRAFT when writing to advertisers

The New EXPLORER SHORT WAVE

Plugless Power Converter

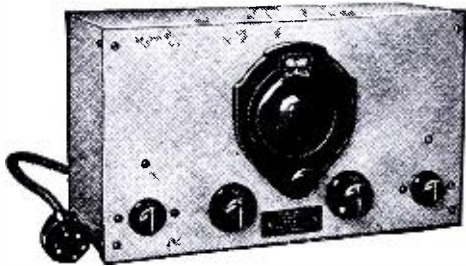

*A revolutionary advance
in short wave reception*

Wave-length range 15 to 160 meters

NO PLUG-IN COILS POWER RECEPTION

Wave-length range 15 to 160 meters; the old, troublesome plug-in coils are completely eliminated! Automatic Band Selector changes wave-length bands by the turn of a knob in less than a second—an original and exclusive EXPLORER achievement.

The EXPLORER itself uses two tubes, greatly amplifying distant signals. Attached to your present broadcast receiver, it uses in addition the amplification of the receiver, making possible reception of short wave stations all over the world with real loud-speaker volume.

With the EXPLORER you can obtain the best possible short wave reception at the lowest cost. Built on entirely new principles of converter design, it is full-sized, thoroughly shielded, and enclosed in a beautiful satin-finish aluminum cabinet.

A special vernier tuning condenser with an effective ratio of 200 to 1 permits ease of tuning like a broadcast receiver's. Results obtained are unsurpassed by expensive short wave receivers, and the elimination of plug-in coils makes the EXPLORER the most convenient of all short wave receiving apparatus.

PRICE \$24.50

Models for every type of receiver, including all superheterodynes. Order now! Sent C.O.D. on receipt of \$2 deposit, or prepaid on receipt of price in full. State make and model of receiver, and tubes used. Foreign, price \$25.50; remit in full with order.

Send for Free Literature Today

RIM RADIO MFG. CO.
691 Grand St., Brooklyn, N. Y., U.S.A.

Two or More Programs on a Single Ultra-Short Wave

By Baron Manfred Von Ardenne

(Continued from page 17)

connecting lead to the radio set are completely shielded; so that there is no fear of getting disturbances from the radio field during ultra-short-wave reception. **Crystal Receivers Sufficient as Supplementary Receivers**

In experiments on waves between 3 and 9 meters, it appeared that operating such supplementary receivers is no harder than using a set for local reception. *Such ultra-short-wave reception could therefore, even today, be suited to the ordinary person.* In a limited area around the ultra-short-wave transmitter, simple crystal circuits are sufficient as the supplementary apparatus; such a device is shown in Fig. 3. Even with tubes, the expense of the supplementary set can be kept low, if the power pack of the radio apparatus serves at the same time to provide current to the supplementary set.

Modulating short waves of somewhat greater length by modulated radio frequencies, as I have learned since, is a procedure several times proposed and even carried out. The lower carrier frequency, the fluctuation phenomena, and the audibility at great distances, however, prevent the uses previously described. It is only with the ultra-short waves that the described possibilities coordinate to make a complete system promising success.

After the technique of sending and receiving of multiple-modulated ultra-short waves has been mastered in the most important points, the most advantageous applications will automatically result. Possibly the entire program of such an ultra-short-wave transmitter will be composed of, say, one or two long-wave transmissions which are of special interest, and of several waves which are modulated by audio-frequency signals locally available or conducted to the transmitter by land-line.

Extremely great are the possibilities of the multiple modulation of ultra-short waves for television. A very broad frequency-band, for the image, making detailed pictures possible, and two narrow radio-frequency bands for synchronizing and audio transmission, can be transmitted directly on one ultra-short wave. In the application to television, it is important, for the simplicity of the entire apparatus, that the receivers for image reproduction, synchronizing, and sound should be capable of being directly connected behind the supplementary set; and that these receivers should be relatively insensitive, if the supplementary set (like that described above) is to contain an aperiodic stage (multiple tube!) which amplifies simultaneously the different radio frequencies.

**More About
ULTRA-SHORT WAVES
In Our Next Issue!**

Amateurs— Experimenters

If you are interested
in

Commercial RADIO Operating

you should read
"CQ", the only
magazine OF, BY
and FOR profes-
sional radio opera-
tors, and learn the
FACTS regarding
conditions existing
in the commercial
radio field.

Send for a copy of "CQ"

"CQ", 1725 Bedford Road,
San Marino, Calif.

I am interested in obtaining
information on the subject of
commercial radio operating.

I enclose 15c for a copy of
the latest issue of "CQ".

I enclose \$1.50 for one
year's subscription to "CQ".

Name

Address

SWC-1

**Be Sure to Read the
IMPORTANT
ANNOUNCEMENT
On Page 72 of this issue—it is
worth while**

7-Inch Waves Span 21 Miles

(Continued from page 11)

Action of Hemispherical Reflector

The function of this hemispherical reflector is illustrated in the diagram, the effect of diffraction being neglected in this description, although in practice it must be taken into account. It will be seen that the direct radiations, such as AB, pass straight to the paraboloidal reflector and so are directed towards the distant receiver; whereas waves such as AC are reflected by the hemispherical reflector back through A upon the paraboloidal mirror at D, and so out in the required direction.

It is estimated that the gain due to the paraboloidal reflectors on one channel is of the order of 46 decibels, to which the hemispherical reflectors add another 6 decibels.

How Ultra-Short Waves Are Measured

A further interesting point is the arrangement made for measuring the

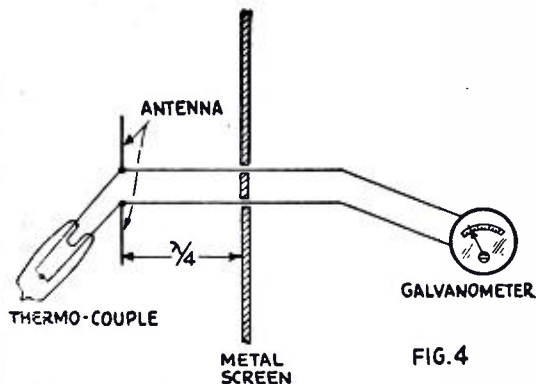

Wavemeter used to measure 7-inch waves at transmitter.

high-frequency output at the transmitter. For this purpose there is provided in the center of the paraboloidal reflector an aperture through which part of the radiation passes. By making the diameter of the aperture slightly smaller than that of the hemispherical reflector, no loss of radiated power results. The radiations passing through the aperture fall upon the special measuring instrument (wavemeter) employed, as indicated diagrammatically; it is calibrated for and normally set to the transmitted frequency. It comprises a small receiving antenna in which the induced E.M.F. is used to act upon a thermo-couple junction. The readings of the associated galvanometer are an indication of the radiated power; while the distance between the antenna and metal screen, being adjustable, also enables wavelength measurements to be made. In the demonstration the wavelength used was 18 centimeters (7 inches), while the radiated power was about half a watt!

The Receiver Details

The receiver is a counterpart of the transmitter; except that no high-frequency measuring device is provided. That is to say, it comprises a doublet connected by a transmission line to the "micro-radion" tube where detection

Now Ready

The NEW 1931 TROUBLE SHOOTER'S MANUAL

by JOHN F. RIDER



Endorsed by the Radio Service Managers' Association of New York City.

Complete with the FREE Question and Answer service.

This volume is the most extraordinary book ever prepared for the radio service man! It represents the data compiled during the past 11 years and nothing ever published for use by the Radio Service Man is as complete and as comprehensive as this work by John F. Rider.

More than 950 pages!
More than 1500 diagrams!

Whatever your problem in connection with radio service work, the 1931 Trouble Shooter's Manual will supply you with the vital data concerning the circuit, the socket layout, the set analyzer voltage data, the color code, the internal connections, of enclosed units, chassis structure, peculiarities in the radio receiver.

If you have any special problems John F. Rider will be glad to furnish you whatever additional data you may require. If you purchase the manual your questions will be answered free.

For the first time since the existence of the radio service industry, ONE book contains ALL valuable data. We want you to understand that John F. Rider spent nineteen (19) months compiling this book. In it you will find the WHOLE line of receivers manufactured by the popular American and Canadian receiver manufacturers.

COMPLETE—COMPREHENSIVE—UP-TO-DATE—it covers the entire radio and public address field.

The book is divided into eleven (11) sections.

- Section 1.—A modern Radio Service and Trouble Shooting Course.
- Section 2.—An explanation of the principles and application of Set Adjusters.
- Section 3.—Vacuum Tube Data and Tables.
- Section 4.—Wiring diagrams of ALL popular commercial receivers manufactured since 1920.
- Section 5.—Wiring diagrams of public address and power amplifiers, inclusive of the products of the most famous manufacturers.
- Section 6.—Wiring diagrams of ALL popular eliminators and power packs.
- Section 7.—Wiring diagrams of ALL popular short wave receivers and adaptors.
- Section 8.—Wiring diagrams of ALL popular kit receivers, old and new.
- Section 9.—Wiring diagrams of the popular Set Analyzers, old and new.
- Section 10.—Wiring diagrams of midjet receivers.
- Section 11.—Peculiarities in radio receivers, a section which you can remove from the book, bind separately and carry with you. This section is a distinct innovation in radio service literature. It will tell you of any special features which you must know when testing the receiver. Every commercial receiver in the 1931 Trouble Shooter's Manual by Rider is mentioned in this section.

No matter what other books you may have, YOU NEED THE 1931 TROUBLE SHOOTER'S MANUAL because it includes many diagrams and details which have NEVER BEFORE appeared elsewhere. . . . This book contains many diagrams which are not available from any other source. . . . Remember that one diagram with color code may save you enough time and enable you to complete a successful repair in such fashion that it will repay you for the entire cost of this book. . . . Hot off the press!

The free question and answer service personally conducted by John F. Rider will be worth a lot of money to you. . . . It is FREE with the 1931 Trouble Shooter's Manual. . . .

The book is looseleaf, beautifully bound. The pages are 8½ x 11 inches. The drawings are large and easy to read. ALL of the vital data is shown upon the same page. Electrical constants are furnished. . . . No expense was spared to compile this book. IT WEIGHS 6 POUNDS. . . . Every man who is doing service work should have this book!

SOLD WITH A MONEY BACK GUARANTEE. IF YOU DON'T LIKE IT, SEND IT BACK AND YOUR MONEY WILL BE REFUNDED. WE ARE CERTAIN THAT YOU WILL BE MORE THAN PLEASED.

We are in a position to supply individual diagrams of receivers and to answer questions for service men. Write to us.

PRICE \$5.00 Postpaid. We will send the book C. O. D.

RADIO TREATISE CO., INC.

1440 Broadway - - - - - New York City

PATENT Z. H. POLACHEK
YOUR IDEAS REGISTER YOUR TRADE-MARK BY 1234 BROADWAY 31st NEW YORK
REG. PATENT ATTORNEY-PROF. ENGINEER

CALL or SEND your SKETCH or Simple Model for CONFIDENTIAL ADVICE No Charge for Consultation

— — — COUPON — — —

Dear Sir:—Please send me full information and literature about Patent Protection, without obligation.

Name
Address

D O I T N O W

QUALITY TRANSMITTING AND RECEIVING APPARATUS AT BARGAIN PRICES SEND FOR CATALOG

HARRISON RADIO CO. 189 Franklin St. - Dept. C. - N. Y. C.

RADIO MAP OF NORTH AMERICA

Showing all Countries, States and Provinces and all Cities having a broadcasting station.

*Printed on good paper, 22 x 22
with cover.*

*Simple method of measuring distances.
Time zones accurately shown.*

Contains complete list of broadcasting stations arranged geographically, with power, call letters, frequencies and key for instant location on map.

Price only 25 cents

Every radio listener should have one.

RADEX, The Radio Fan's Own Magazine. Contains the most complete, accurate and up-to-date list of broadcasting stations published.

Cross-indexed by dial numbers, frequencies, wave-lengths, call letters and countries, states and cities.

So arranged that merely entering dial numbers calibrates any set thus showing exactly where to set dials even for stations never before received. "What's on the Air Tonight?" and "What's Wrong With My Set?" are two regular and interesting features.

25c per copy, \$1.75 per year

THE RADEX PRESS, 5005 Euclid Ave., Cleveland, Ohio

takes place. Paraboloidal and spherical mirrors, exactly similar to those of the transmitter, are also provided for concentrating the received waves upon this doublet.

To avoid coupling, the receiver at each terminal is situated about 80 yards from the transmitter and is arranged to be in the electro-optical shadow of the latter; adequate allowance being made for diffraction. The same wavelength is used for both sending and receiving.

The success of this demonstration has definitely shown that a wavelength range as low as 10 centimeters (4 inches) is opened up. The importance of this, from the point of view of present ether congestion, need hardly be stressed. Calcula-

tion will show that the range of frequencies available in the "micro-metric" waveband (between 10 and 100 centimeters or 4 to 40 inches) is some nine times as great as in the whole of the ordinary radio field. Added to this is the fact that the radiations can easily and cheaply be concentrated into a small solid angle.

Commercial applications in a worldwide communication network like the International System are obvious.

The frequency band available will permit the working of a very large number of permanent and continuous channels between the same places without mutual interference.

Application to Television Seen

A further very important use will be for television transmission. The present difficulty with regard to television is the very large frequency-range required for satisfactory definition of the object transmitted. It should now be possible to allocate as wide a band as is necessary for television, without causing any ether congestion.

Valuable applications seem possible in ship-to-ship communication; since the small size of the equipment would enable easy use to be made of its directional properties. In addition, the *micro ray system* affords a satisfactory method for virtually secret inter-communication between war vessels.

Demonstration was also given of the high-speed facsimile transmission system developed by the International Telephone and Telegraph Laboratories.

While this successful demonstration proves the practicability of the micro ray, further refinements are being carried on to prepare it for everyday commercial application.

Getting Started on 5 Meters

By E. T. SOMERSET, G2DT

(Continued from page 32)

in plan, a quarter-wavelength equilateral triangle, with one wire used as the radiator. If it is decided to feed the radiator with a single transmission line, and if the radiator is to be a half-wavelength long, then the point of juncture of the feed line to the radiator must be exactly 4 inches from the home end, for maximum performance on a frequency of 57,000-kc.

If it is decided to feed the radiator with Zeppelin twin feeders, then a pause must be made to consider losses in the feed system; the writer has found that these are very much in evidence at these high frequencies and it is his opinion that, comparing a 7,000-kc. wave with one of 56,000-kc., the losses of leakage from feeder to feeder of the latter are eight times as much, with the result that very little power is going into the radiator.

The only thing to do, if a current-feed system is to be used, is to start to spread out the feeders in ratio to the assumed leakage. To explain this more fully, it will be assumed that the feeders are each ten meters long, when there will be really two fundamentals thereon. This means that the feeders must be spread out eight times wider for the first five meters, and eight times for the second; totalling sixteen times greater than the distance at the start. Thus, if the feeders at the transmitter are spaced 8 inches apart, they should have this spacing progressively increased until they are ten feet eight inches apart at the point of connection to the radiator.

Finally, there is to be considered beam aerials. This is simple to build, and it is hoped that the sketch in Fig. 5 will be self-explanatory.

When Hellmut Goes Gunning for Action

By WILLIAM BURKE MILLER

(Continued from page 9)

waters of Long Island Sound at a depth of forty feet.

These represent particularly noteworthy broadcasts in which NBC portable short-wave transmitting equipment was used.

The Auto Truck S-W Transmitter

A word anent the mobile short-wave transmitting unit: This is mounted on a motor truck, and is available for quick operation at the scene of an unusual event. The mobile unit is equipped with a 50-watt 100% modulated, crystal-control transmitter, and has microphone leads ranging from fifty to a thousand feet in length. The "mikes" are of the portable type and can be carried close to a "scene of action". The transmitter may also be removed to an airplane or ship; while antenna may also be used on the roof of the truck, or attached to a suitable support at the scene of action.

As announcers speak into the short-wave transmitter, the words are picked up by one of NBC's receiving stations, which, located in various vantage points in and about Greater New York, then relayed by land-line to radio headquarters at 711 Fifth Avenue, and sent out over NBC networks from there.

For this purpose an expert engineering staff, headed by R. M. Morris, who is NBC's development engineer, and Max Jacobson, field supervisor, is assigned to the mobile unit.

"Body" Transmitter Weighs But 24 Lbs.

The "transient transmitter" offers a wide range of flexible possibilities. It is small and compact, weighing only 24 pounds, but none the less efficient. The transmitter proper can be held in the palm of one hand; it is contained within a case five inches by seven and one-half by three inches.

Besides this, there is a larger case, with special shoulder-harness, which contains a complete modulation and oscillator system, with four batteries providing a higher voltage than the average home-lighting circuit.

The set transmits on short waves with a power of 500 milliwatts, and has an effective range of ten miles; so that within one mile its signals are excellent. Sending apparatus is used with a "chin-strap" microphone, which leaves the speaker's head free to turn in any direction and both hands likewise unemployed.

Signals are received in the usual manner at remote-control headquarters, and pass through a mixing panel directly into the wire lines whenever desired.

"Walking" Station Transmits on 25 Meters

When it is in operation, signals from the tiny broadcast apparatus are picked up on a short-wave receiver, located as near the scene of operations as possible.

A Good Time to Rebuild Old Sets

using

DONGAN

Replacement Transformers

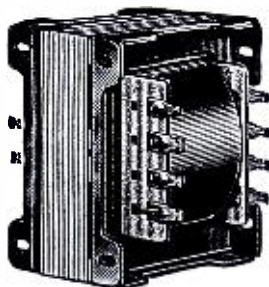

No. 6952
\$7.00 list.

A universal type for use with midget receiving sets using up to four UY 227 or UY 224 tubes, one 245 and one 280 tube.

Secondary voltages:
315-315 volts 60 mils.
2½ volts, 8½ amperes
C.T. 2½ volts 1½ amperes
C.T.; 5 volts 2 amperes.

New Transformers, like new Tubes, may rejuvenate that old set for another year. Dongan Replacements are universal — fit all sets, slotted brackets permit mounting on side or end without drilling holes.

Replacement Transformers for all Models

Write for new Booklet free on request



Dongan Electric Manufacturing Company

McDougall and Franklin Streets, Detroit.

Get The Lowest Price-First! on thousands of NATIONALLY ADVERTISED ITEMS FROM THIS BOOK Write for it!

FREE American Radio Catalog **SALES CO.**

C-44 W. 18th St. New York City

LEARN BY LISTENING **Telegraphy** Morse or Continental

TELEPLEX is more than a machine—it is a SYSTEM. It teaches you expert sending and receiving Morse or Continental Code—for amateur work or a good-pay position. TELEPLEX is used by the U. S. Army and Navy and leading radio and telegraph schools.

Write for Folder SW-6
Teleplex Co.
76 Cortlandt St., New York

Teleplex

LUGGAGE

BUY AT WHOLESALE PRICES

Save 40% by Dealing Directly with One of America's Leading Luggage Manufacturers.

"GLADSTONE" OF GENUINE TOP GRAIN COWHIDE LEATHER, \$12.50

The ever popular Gladstone, with solid brass locks and catches. Short leather outside straps. Lined with very fine quality tan twill cloth. Comes in choice of Brown or Black Shark Grain Genuine Cowhide.

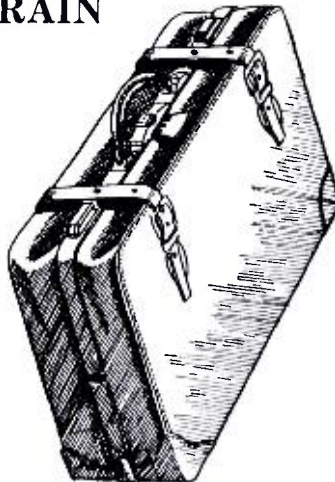

Size 22 and 24 inches (choice)

OVERNIGHT CASE \$2.95

DANDY PORTABLE RADIO AND INSTRUMENT CASE

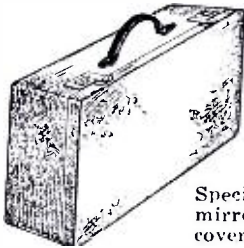

Built over solid wood frame, covered with durable Fabricoid that wears better than cheap leather. Lined with good quality cloth. Has neat shirred pockets in lid and body. Size 16 inches. Strong leather handle; 2 locks; colors, Brown or Black.

Special "Overnight" Case: Silk-lined, beveled mirror in cover. Brass locks, leather handle, covered with Dupont. F.O.B. 12x14 in. \$2.95

Same case, Genuine Cowhide.....\$4.95

FOR GOLFERS, SPORTSMEN AND TRAVELERS

Made of Solid Hand-Boarded Cowhide

Roll Golf and Sports Bag, with Zipper. Exceptional value. Genuine Hand-Boarded Cowhide in Russet and Brown.
Size: 18-inch, \$10.50 Size: 20-inch, \$11.00
(F.O.B.—New York)

Fitted with Lock.

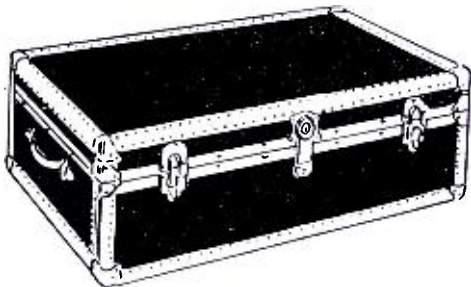
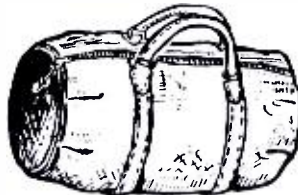

HANDSOME "CAMP" TRUNK and LOCKER

Handsome Camp Trunk and Locker, made of three-ply veneer basswood, covered and bound with fibre, strong draw bolts and good snap lock, three hinges. This trunk has the special feature of "dust-proof" tongue and groove steel molding around the opening edges of trunk.

Interior of trunk has one tray with three compartments. Color: Maroon Body, Tan Binding.

Size: 32-inch, \$10.50 Size: 36-inch, \$11.50
F.O.B.—New York.

SOLID 5-OZ. LEATHER BRIEF CASE

Wide cowhide straps all around. The top of the gusset is folded to give more strength. Whole case double stitched and riveted at the corners. Flap reinforced with leather 1½" wide. Size 16x11 inches. Colors: brown, black or mahogany.

- \$3.50—Model D—2 pockets.
- \$4.00—Model E—3 pockets.
- \$4.50—Model F—4 pockets.
- \$5.00—Model G—5 pockets.

All prices F.O.B., New York



Mail Orders only—no C.O.D.'s—All Prices are F.O.B. New York. Satisfaction Guaranteed or money cheerfully refunded. Send Money Order or Check. Be sure to get our prices on all Luggage and Trunks.

"C and S" Supply Co.

221 FOURTH AVE.,

NEW YORK CITY, N. Y.

Please mention SHORT WAVE CRAFT when writing to advertisers

They are then transferred to specially-compensated telephone wires which convey them to headquarters at 711 Fifth Avenue. Usually, a thirty-foot antenna is suspended between two poles and carried about following the speaker.

During the 1929 visit of the *Graf Zeppelin*, the transmitter operated on 127 meters and 2,368 kilocycles, under the call letters of W2XBF.

Today NBC makes use of two such "stations" whose call letters are WIO-XAO and WIOXAL, which operate respectively on frequencies of 2,392 kilocycles (25 meters), and 1,584 kilocycles (194 meters).

The most ambitious attempt, in the catalogue of spectacular radio stunts, will be staged during the forthcoming United States Army air "strafe" of New York City on Saturday afternoon, May 23.

This broadcast—planned as a complete verbal and sound-effects account of the aerial attack on Manhattan—will be the first time in the history of aviation broadcasting when announcers, flying in planes and stationed at vantage points along the line of attack, will give listeners a complete, running account of each step in the mimic aerial attack.

An elaborate system of short-wave intercommunication, between announcers atop Manhattan skyscrapers and other announcers in planes, will keep NBC's vast audience in touch with the "battle".

Short-Wave Converter With "B" Supply Built-in

By JACOB P. LIEBERMAN

(Continued from page 19)

the plate circuit of the modulator is also such a resistor. By that method all trapping effects, due to large distributed capacity (which might be present in high-inductance radio-frequency choke coils) are avoided; and not only is response obtained all over the dial, but high sensitivity as well. Chokes of small inductance could also prevent dead spots, but might not afford as much sensitivity.

Even the grid leak has very low resistance, compared with values used for broadcast frequencies, while the grid condenser is a Hammarlund equalizer, 20-100 mmf., set at full capacity. This combination of grid-condenser capacity and leak resistance gives a time constant of 2 micro-seconds; hence it takes only two one-millionths of a second for the condenser to discharge to a little less than half its original charge. With a small time constant, the amplification is good on high frequencies.

As for operation, you yourself must select the most suitable intermediate frequency; this will be gleaned from experience. Most receivers now in use are more sensitive at the higher frequencies. Of late sets, particularly those in the 1930-31 production class, the opposite is true. If your receiver is so sensitive that you pick up broadcasting at almost all dial points in the

Short Waves with a Converter!



With high-gain radio frequency amplifiers characterizing experimenters' broadcast receivers today, and audio amplification remarkably faithful, it is convenient, economical and easy to tune in short waves and television with a converter. In that way you use your entire broadcast receiver just as it is, and besides the television band, tune in other short waves. The range is 25 to 600 meters, when the broadcast set is worked at a high frequency, around 1,500 kc.

The converter illustrated is model PR-3FS and has a filament transformer built in. There are only four external connections to make, and one of these is to a positive B voltage, 50 to 180 volts, taken from the receiver. If you have a screen grid set you may take this voltage from the screen of a radio frequency tube, by looping the bare end of the B plus lead and slipping the screen prong of the tube through the loop before reinserting the tube in the set.

The converter uses three 227 tubes and plug-in coils of the tube base type. There is an A.C. switch built in, but there is only one tuning dial (at right). The condenser is the new Hammarlund Junior Midline of .0002 mfd. capacity. This short-wave converter has proved highly satisfactory, developing great sensitivity and enabling the penetration of great distances. There are no body capacity, no squealing, no squawking and no tricky tuning.

By all means provide yourself with the complete parts of this dandy converter, as specified by Herman Bernard, the designer. Free with a two-year subscription (104 issues) at \$12. Order PR-3FS.

Short-Wave Condenser

The newest condenser to come from the laboratories of the Hammarlund Manufacturing Co. is the Junior Midline, made especially for us, and designed for highest grade short-wave performance. The capacity is .0002 mfd. and the midline tuning characteristic prevails. Single hole panel mount, in a 3/8-inch hole (with option of sub-panel mounting by built-in brackets); end stop provision at both extremes; rigid plate assembly and the fine workmanship of Hammarlund mark this compact condenser. The overall depth of the frame is 1 1/2 inches, while the rotor plates turn in a diameter of only two inches. This condenser, our Model PR-H-20, is a superb product, in line with the modern vogue of compact parts. Free with a 6-month subscription (26 issues) at \$3. Order PR-H-20.

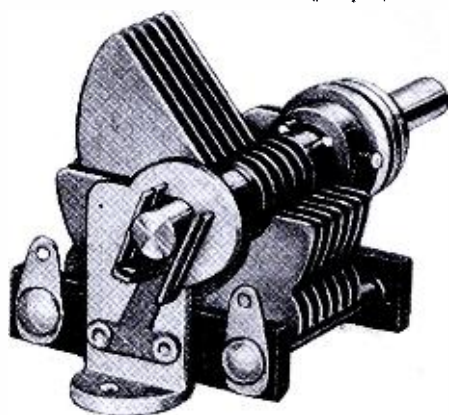

RADIO WORLD, now in its tenth year, is the first and only national radio weekly, and publishes the latest, up-to-the-second news of circuits, both of kit types and of 1931 commercial receivers, as well as news of happenings in the broadcasting field. Lists of broadcast and short-wave stations, including television stations, are published regularly. You get your information weekly—which means quickly—and you get it accurately, so be sure to become or remain a subscriber for RADIO WORLD. We are able to offer now premiums especially attractive to short-wave experimenters, and ask you to make your choice from the parts offered on this page.

The regular subscription rates are: \$12 for two years (104 issues), \$6 for one year (52 issues), \$3 for 6 months (26 issues).

RADIO WORLD - 145 West 45th Street - New York, N. Y.

The "Egert" SWS-9 Super-Het

By JOSEPH I. HELLER, E.E.

(Continued from page 45)

which is a mounting flange 1/4-inch wide). Holes are drilled in one end for the antenna and ground binding posts. It is heavily covered with black crystalline lacquer; dull black lacquer is used on the inside of the over-all shield, which is bent to shape. All wiring should be made as direct as possible.

Adjustment and Operation

Now a few words as to the adjustment of the receiver; turn all the I.F. adjusting condensers (which can be reached through the top of the I.F. transformer cans) all the way down. Put the tubes into their respective sockets. If everything has been wired correctly, it will be found that, on placing the hand on the

first I.F. screen-grid tube and bringing the volume and regeneration controls on, loud "static" will be heard; it may be that a regular long-wave broadcast station will also be heard. Turn all the intermediate condensers out, about half a turn each, and plug in the largest coil. On tuning the main controls over their entire range, a point where a station is heard rather weakly will probably be reached. With the station tuned to the loudest possible volume, adjust all the intermediate condensers with a bakelite screw-driver until the station is as loud as you can get it. (Do not have the regeneration control all the way on; but leave it at some point below oscillation.) Tune very carefully, as the intermediate

tunes sharply. If you have had any experience in tuning such receivers, you will find that you will be able to make a rather good job of lining up the intermediates, by merely adjusting for the static level.

The adjustment of the regeneration control should be left at some point which gives maximum response for one station; and thereafter tuning should be done with the main tuning control and the vernier to its left. Variations in volume should be taken care of by means of the volume control. The set should now be ready to use.

While tuning, if you hear a broadcast station, don't pass over it because it is loud; get the call letters, if only to calibrate the receiver. The reason for this statement is the fact that most people, while tuning this receiver, go past any station that happens to be loud, thinking it only a powerful local. It takes quite a while to get used to the fact that (as in most cases when we have tried the receiver) *the distant stations may be as loud, if not louder than the local!*

List of Parts

- Two Hammarlund "Type ML-7" 140-mf. variable condensers (C1, C3);
- One Tobe Deutschmann .00015-mf. fixed condenser (C2—to be mounted directly on cap of screen-grid tube);
- One Pilot "Type J-23" .0001-mf., variable condenser, (C4);
- One Dubilier .00015-mf. fixed condenser, (C5);
- Four Polymet "Siamese" 0.25-mf., by-pass condensers (C6, C7, C9, C10, C13, C14, C19, C20);
- Three Hammarlund "Type EC-80" 80-mmf. equalizing condensers (C8, C11, C15);
- Two Sangamo .01-mf. fixed condensers, (C12, C16);
- One Polymet .0002-mf. fixed condenser (C17);
- Two Polymet .002-mf. fixed condensers, (C18, C24);
- One Dubilier 1,000-volt 1-mf. fixed condenser (C21);
- Two Polymet electrolytic 8-mf. fixed condensers (C22, C23);
- One Polymet 0.5-mf. fixed condenser, (C25);
- One Durham 25,000-ohm fixed resistor (R1);
- Two Durham 2-meg. resistors (R2, R7);
- Three Lynch 10,000-ohm fixed resistors (R3, R4, R10);
- Two Durham 500-ohm fixed resistors (R5, R6);
- One Clarostat 500,000-ohm potentiometer (R8);
- One Clarostat 50,000-ohm potentiometer (R9);
- One Durham 5,000-ohm fixed resistor (R11);
- One Lynch 10,000-ohm heavy duty limiting resistor (R12);
- Two Durham 20-ohm center-tapped resistors (R13, R15);
- One Cresradio 780-ohm 25-watt resistor (R14);
- One Electrad 20,000-ohm tapped voltage divider (R16);
- One Durham 2,000-ohm resistor (R17);
- Four W.E.E.Co. 115-millihenry R.F. chokes (RFC1, RFC2, RFC3, RFC4);
- Five General Radio plug-in jacks and plugs (J1, J2, J3, J4, J5; these must be insulated from the metal front panel.—*Technical Editor*);
- One National "Type VIIC" drum dial;
- One Arrow-H.&H. toggle switch, Sw.;
- One Metal front panel;
- Three W.E.E.Co. "Types LL, LM, and LH" shielded plug-in inductances, one each (L1; see text);
- Three W.E.E.Co. "Types IF1, IF2, IF3" shielded I.F. transformers (one each L2, L3, L4; see text);
- One Amertran first stage "DeLuxe" A.F. transformer (T1);
- One Amertran "Type 151" input push-pull A.F. transformer (T2);
- One Amertran "Type 443" (for dynamic reproducer), or "Type 442" (magnetic reproducer), output push-pull A.F. transformer (T3);
- Two Thordarson 30-henry, 75-ma. filter chokes (Ch. 1, Ch. 2);
- One W.E.E.Co. "Type PT 116" power transformer (PT);
- Nine Cinch tube sockets, three UX and six UY.

Please mention SHORT WAVE CRAFT when writing to advertisers

2-Volt Tube Receiver

By JOHN CARTER

(Continued from page 51)

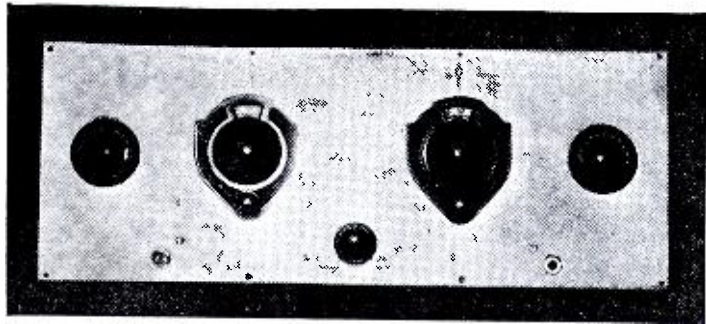

The 2-volt tube S-W receiver fitted with vernier dials.

be able to build this set in a few evenings. No elaborate kit of tools is needed; the author used only a pair of pliers, screw-driver, drill and a soldering iron.

A sheet of aluminum is mounted on top of a wooden baseboard and fastened by four screws, one in each corner. The two shield cans are very durable, with ample space for the coils and tubes. The heavy aluminum sides slide into grooved aluminum posts, which have large overlaps and are held firmly in position by four screws. A hinge is easily affixed to each shield, by drilling four small holes, and is bolted to the box; this is very handy when changing coils. The three plates that shield the condenser C1 and C2 are very efficient.

Only one wire connects to each of the condensers C¹, C² and C⁴. The rotors of these condensers and the "F—" terminals of the tube socket are bolted to the chassis and the chassis is grounded; which makes a common return and saves time in wiring. Shielded wire is used throughout and is point-to-point; all connections being soldered. (Care should be exercised not to use too much flux as this will cause leakages.) It is very important that all holes drilled in the aluminum shield boxes for the wiring connections should be made as small as possible, so that the shield on the wire fits the hole snugly. This grounds the shields around the wire and helps stray radio-frequency currents from entering the boxes.

All terminal connections are brought to the rear of the set and mounted on a strip of bakelite. The aerial condenser C4 and the phone jack are insulated from the aluminum panel with mica or bakelite washers. Two round aluminum cans, of the type used for coils, serve to shield condensers C³ and C⁴.

An aerial sixty to seventy feet long, using single-stranded copper wire, was found very satisfactory, and the selectivity of the set was also very good; this is made possible by the use of condenser C3. The setting of this condenser depends upon the length of aerial used but, generally, it must be lowered as the desired wavelength is lowered. Use a good ground connection, preferably direct to the ground; if this is not available, a water pipe should be used. Care must be taken that all paint and corrosion is removed and the pipe scraped until the clean metal shows. More short-

wave circuits fail to oscillate from the lack of a good ground connection than any other known cause.

The two main tuning dials are C1 and C2; the oscillation is controlled by C4. To simplify tuning, and to make possible accurate logging, small calibrated dials instead of knobs are used to rotate C3 and C4.

The attractiveness of the panel and the symmetrical layout of the parts put this receiver on a par with any set. In New York City this set has brought in England, Holland and numerous American stations.

List of Parts

- C1, C2.....Two Hammarlund 125 - mmf., Midline condensers;
- L1, L2.....Two sets of Hammarlund plug-in coils;
- C3One Hammarlund 65-mm. variable condenser;
- C4One Hammarlund 100-mm. variable condenser;
- C5One .0001-mf. Aerovox fixed condenser;
- C6, C7, C8, C9...Four .01-mf. Aerovox fixed condensers;
- C10One .002-mf. Aerovox fixed condenser;
- R1One Electrad, 4-megohm grid leak and mount;
- R2One Electrad 100,000-ohm rheostat;
- R3One 10,000-ohm Aerovox resistor;
- R4One 400-ohm potentiometer;
- Z, Z, Z.....Three Hammarlund 250 chokes;
- TThree UX tube sockets;
- JOne Aluminum panel, 7"x16";
One Sub-panel, 8½"x14";
One Audio transformer
Two Blau "A-1" aluminum shield boxes;
Three Alcoa aluminum shield plates;
Two Aluminum coil shields;
One phone jack;
One filament switch.

The Superior Short-Wave Receiver Used at G2DT

By E. T. SOMERSET

(Continued from page 33)

All values and coil-winding data are appended to the diagram.

- C1=100 mmf.
- C2=Tank 94 mmf.
Vernier 18 mmf.
- C3=150 mmf.
- C4=0.01 mf. Mica
- C5=4.0 mf.
- C6=4.0 mf.
- C7=0.1 mf.
- C8=2.0 mf.
- C9=0.1 mf.
- R1=4 Mr.
- R2=25,000 r.
- R3=50,000 r.
- R4=100,000 r.
Wire Wound.
- R5=0.5 Mr.

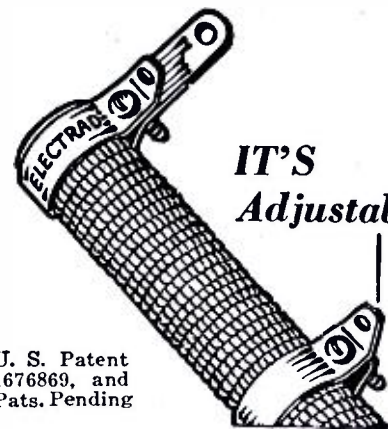

IT'S Adjustable

U. S. Patent 1676869, and Pats. Pending

TRUVOLT

The Most Adaptable RESISTOR

IN short-wave work, particularly, correct "B" and "C" voltages are essential to proper performance of your receiver.

Accuracy in voltages means more miles covered and more signals logged.

The exclusive adjustable clips on TRUVOLT Resistors provide the utmost convenience in fixing exact voltages. As many clips as desired may be added to make efficient dividers. The patented TRUVOLT air-cooled winding insures stable operation and longer life.

TRUVOLTS are made in all usual sizes. Also 22 stock sizes of variable TRUVOLTS with knob control.

For Quiet Control of Volume

ELECTRAD Super-TONATROL

Not a scratch when you adjust volume with the Super-TONATROL, Electrad's 5-Watt, long life volume control. This better volume control is stepless. Pure silver 8-point floating contact assures positive connection with resistance element. Shielded all-metal construction. 7 types for all usual requirements, \$2.40 to \$3.50.

Mail coupon for complete, new 36-page catalog containing helpful data.

175 Varick St., New York, N.Y.
ELECTRAD
INC.

ELECTRAD, INC., Dept. SC-6, 175 Varick Street, New York, N. Y.

Please send technical data on TRUVOLT and Super-TONATROL. Check here for complete catalog of all products.

Name

Address

.....

— no greater magazine published on the development of TELEVISION —

4-Color Cover 9 x 12 in.

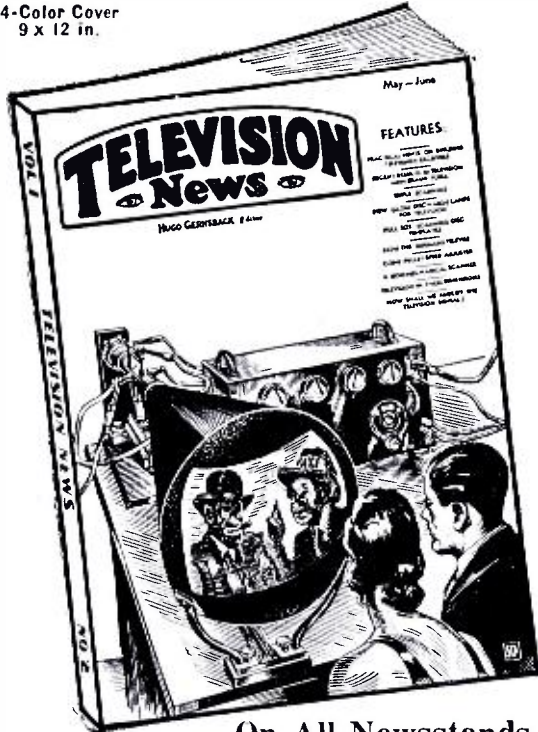

On All Newsstands

A Brief Summary of Contents

Prominent Television Authorities

DR. IVES — CHAMBERLAIN — VON ARDENNE — DR. NOACK — NASON — WEINHART

Columbia Ready to Televise, by A. B. Chamberlain.
 How the Germans Televise, by Dr. Fritz Noack, Berlin.
 Television—A Challenge to the Inventor, by C. P. Mason.
 A Multi-Channel Television Apparatus, by Dr. Herbert E. Ives, Research Dept., Bell Telephone Laboratories.
 Glow-Discharge Tubes for Television, by H. W. Weinhart.
 How to Build the New Jenkins Television Receiver, by H. G. Cislis, M.E., and Charles E. Huffman.
 Television Image and Voice Recorded and Reproduced from Film, by William Strawatka.
 Full Size Template for Disc Layout.
 Complete Instructions for Building Baird Universal Television.
 A Distortion-less Amplifier for Television, by John Vade.
 Television Digest.
 A Universal Television Receiver, by John J. Fettig.
 A Short Course in Television, by C. H. W. Nason.
 This Disc Indicates Its Speed Automatically, by Paul L. Clark.
 A Multi-Channel Receiver.
 The New Jenkins Television Receiver.
 A Photographic Film Recorder for Television.
 Full Size Scanning Disc Layout Template.
 Baird Universal Television and Short Wave Receiver.

Mirrors Instead of Scanning Discs for Receiving.
 A Universal Television Receiver.
 Power Supply for Television Receivers, by C. H. W. Nason.
 A Perfect Scanning Disc, by Dr. Hans Vatter.
 How to Get Large Television Images.
 A Non-Mechanical Scanner, by George Wald.
 Television Transmitter Used by Chicago Television Studio.
 Columbia Broadcasting System's New Television Transmitter.
 Cathode Ray Tube "Transmitter".
 Multi-Channel Television Transmitter.
 Transmitter Using Photo-Film.
 Simple Elements of a Television Transmitter.
 First "Movie" of a Television Image.
 Hints for the Beginner, by H. Winfield Secor.
 How Shall We Amplify the Television Signal?
 Television Projected in Three Dimensions.
 Cone Pulleys Provide Sensitive Speed Adjustment.
 What Does Your Face "Sound" Like?
 Power Supply for Television Receivers.
 Latest Giant Television Screen.
 Television Question Box.

COMPLETE COURSE IN TELEVISION

Over 175 Illustrations, Diagrams, Circuits and Photographs — Actual Photographs of Television Transmitters and Receivers.

Rush Coupon TODAY!

TELEVISION NEWS SWC 2-1
 98 Park Place, New York, N. Y.
 As per your special offer, I enclose herewith \$2.00 (Canadian and foreign \$2.50) for which enter my subscription to TELEVISION NEWS for One Year.
 Name
 Address
 City..... State.....

Special Offer

VOID AFTER JUNE 30th

The regular price of TELEVISION NEWS is \$3.00 a year (Canada and foreign, \$3.50). Up to June 30th, if you use the coupon at the left, we will accept \$2.00 (Canada and foreign, \$2.50) for a full year's subscription. THIS OFFER WILL NOT BE MADE AGAIN.

Published Every Other Month

Please mention SHORT WAVE CRAFT when writing to advertisers

Short-Wave Amateurs Link Trail-Blazers With Base

By STERLING GLEASON

(Continued from page 14)

lead. Sign language, plus a generous lubrication of judiciously applied pesos, nevertheless accomplished much.

Often Sandham found himself sitting in the middle of the main street or the plaza, surrounded by a crowd of grinning peons, with bustling policemen keeping the crowd at a safe distance, and nondescript dogs—of which Mexico seems to have millions—sniffing curiously at his heels. Once a great bull with long curved horns came up behind the unsuspecting operator, who was completely unaware of its presence until he felt a hot breath on his neck. At Santiago, a herd of pigs being driven through town by some peons, got out of control and bolted straight for Sandham. He dared not abandon his equipment. There remained nothing to do but to sit tight and hold everything possible with a firm grip, and this Sandham did, while the excited creatures stampeded under the radio table.

Road to Extend Through Canada and Alaska

The onset of the tropical spring rains at this point rendered the lowlands to the south impassable; and reluctantly the party returned to Los Angeles. Auto Club officials turned their attention to the northern end of the highway, joining a Canadian expedition through British Columbia to the end of the present road. Official assurance has been given by both British and American governments that the road will be extended through the Yukon and Alaskan territories to Juneau, Alaska.

Radio Amateurs Who Cooperated

While the expedition was working its way through Mexico, American amateurs were busy on the short waves with press and official communications relayed to and from IPH. Chief among the relay stations active in the traffic were the Los Angeles amateurs Charles A. Hill, W6BRO, Charles Lundblad, W6FE, and W. A. Gee, W6EGH; to whom should go a great deal of credit for their cooperation in meeting a rather difficult series of schedules. The work frequently kept these operators at their keys until the wee small hours of the night, some contacts lasting three or four hours without a break. Communication was made difficult by the fact that IPH was followed by severe atmospherics all the way south from Nogales. Press copy averaged at least four or five hundreds words a day, and personal and official messages swelled this total greatly.

The trail blazers are again on their way, having driven to El Paso for a shakedown tour and there entrained for Mexico City.

Sandham will be on the air on 7,330 kilocycles, during the evenings, or 13,900 kc. for midday transmissions.

When to Listen In By ROBERT HERTZBERG

SINCE the last issue of *SHORT WAVE CRAFT* appeared, I have collected a lot of dope on new and old stations. I'll just skip "round the world" lightly and touch on countries here and there. Cut this material out and paste it up in your log book for reference.

Ecuador

Station HC1DR, located at Quito, Ecuador, is a small but active outfit. Opened in May, 1930, as an experimental station by a number of local amateurs, it has gained considerable popularity because of its lively programs. It is on the air nightly except Sunday from eight to ten o'clock, E.S.T., on a wavelength of 48 meters. Reports of reception are desired, and will be quickly acknowledged. Since announcements are made in English as well as Spanish, the station can be identified without much trouble, many listeners in the United States having logged it.

Address your reports to Sr. Arturo Meneses, Box 262, Quito, Ecuador, South America.

South Africa

One of my faithful correspondents in Johannesburg reports that a five-kilowatt short-wave station is now in operation in his city. The wavelength is 49.4 meters and the schedule, daily, is 12 noon to 2:00 p.m.; 4:00 to 6:30 p.m.; and 7:00 to 10:30 p.m. Saturday nights until 11:45 p.m. This is South African Time; get out your time conversion chart* and do your bi-monthly exercise on it.

U. S. S. R.

With one fine short-waver at Khabarovsk, Siberia, the Russians are now adding to their chain, and have opened a new station in Moscow on 50 meters. I don't think anyone in the U. S. has heard it yet, but it is making a lot of noise in Europe and Great Britain. The operating schedule is not known, but it probably follows the usual evening activities. This corresponds to noon and afternoon in the Eastern States and late morning and early afternoon in the Western ones.

(Continued on page 75)

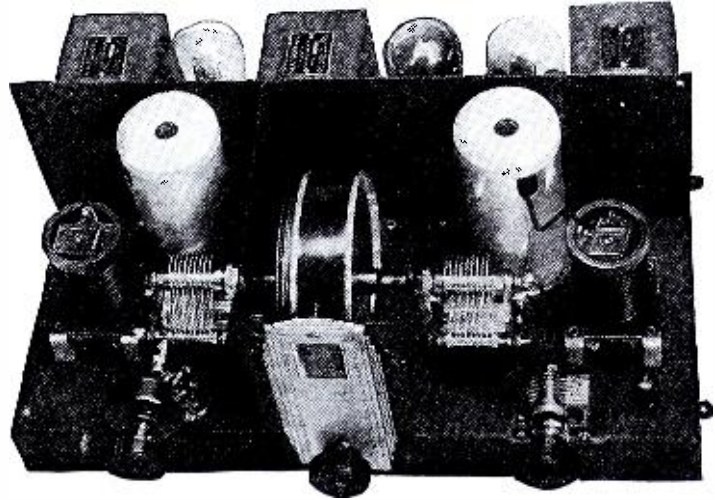

TRUE SINGLE-CONTROL ON THE SHORT WAVES

No two-knob tuning grief with this modern single-control short wave receiver! By the use of the NATIONAL SE100 Tuning Condenser specially designed for short wave work only, coils that keep their original electrical constants, and the Volver Vernier Projection Dial, and because of other special designs, ganging and single control is a reality in the THRILL-BOX.

NOTE: New Band-Spreading Coils are now available which spread the 20,40 and 80 meter Amateur Bands over 50 Divisions.

Just another reason for the outstanding superiority of the NATIONAL SW5 THRILL-BOX. (Send 50c in stamps or coin for new 64-page Short Wave Handbook, giving details of all modern S.W. circuits. Bulletin No. 143 is free.)



NATIONAL CO., INC., 61 SHERMAN STREET, MALDEN, MASS.

New Transformer and Condenser

A NUMBER of new products of special interest to radio constructors, experimenters and service men is announced by the Pilot Radio & Tube Corporation, of Lawrence, Mass. The list includes a power pack, a power transformer and a variable condenser.

The power pack is of the heavy-duty type, designed to meet the power requirements of practically any modern A.C. receiver. Known as the K-139, it is sold factory assembled and wired, all ready to use. It has a formed steel base 14½ inches long and 6¼ inches wide, and stands 6 inches high. The maximum direct current output, for plate supply, is 125 milliamperes at 300 volts. The filament windings for the heating of A.C.

tubes are as follows: 4 volts at 6 amperes; 2½ volts at 12 amperes; 2½ volts at 3.6 amperes; and 5 volts at 2 amperes. The primary of the power transformer is tapped and the same pack may be used on either 110 or 125 volts.

The power transformer, known as the No. 445, will appeal to constructors of voice amplifiers and amateur short-wave transmitters. It has two 7½ volt, 2½ ampere secondaries, for the heating of two 281 and two 210 or 250 tubes, and also a 1,200 volt, center-tapped secondary, capable of delivering 140 milliamperes through the usual rectifier and filter system.

The variable condenser, No. 3022, is intended for use in low-power amateur transmitters. It has two double-spaced sections, with a maximum capacity each of 74 mf., or 148 total. The frame is of rigid die-cast aluminum, with dust-proof cover.

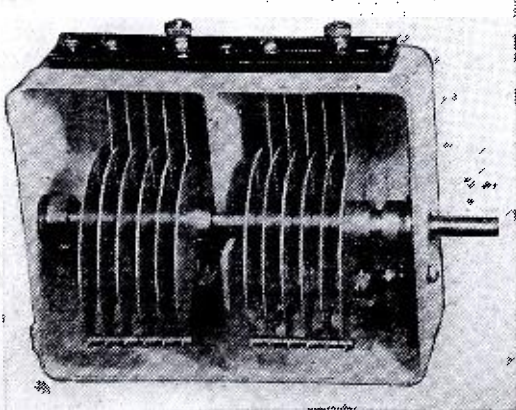

Left: A peek at the inside of the new Pilot transmitting condenser; it has a dust-proof cover.

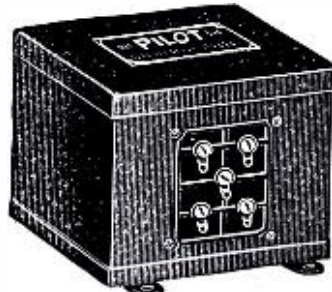

Right: Appearance of new Pilot power transformer.

FREE!

Radio Bargain News

New Number Just Out

Over 2,000 BARGAINS

IN EVERY MONTHLY ISSUE.

8 Pages

OF VALUABLE SERVICE DATA

Federated Purchaser

24 HUDSON ST. N. Y. C.

List of Short-Wave Stations!

Send 15c for a copy of Radio World containing a list of the short-wave stations of the world by frequencies, with the stations' hours on the air given in all five times on zones applicable to the Western Hemisphere.

RADIO WORLD

145 West 45th St. New York City
(Just East of Broadway)

SWS-9 "Proclaimed the Best"

By All Who Know and Use It

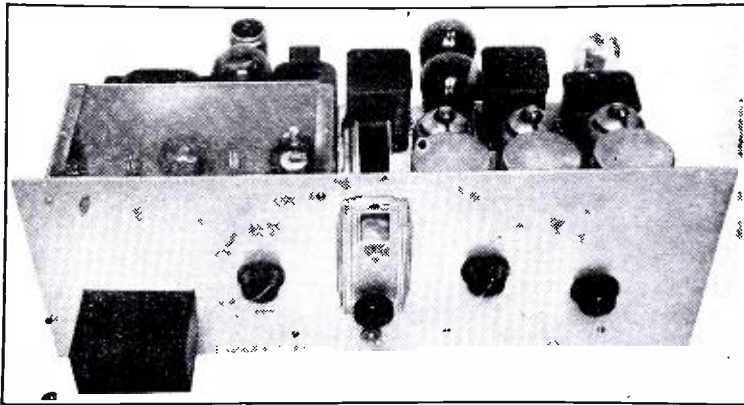

Here is an ideal realized. A Nine-Tube Short-Wave A.C. Superheterodyne that gets everything there is to get in the high frequency bands.

This set represents a decisive step toward the betterment of short-wave reception. Its final design has been the result of two years of painful development work. It now stands as a tall pyramid of "ideals realized" mounted on a rigid base of practicability and the good will of those who have tried its worth.

Complete plans and instructions of how to build this set, \$1.00

Send for our Catalogue "A"

WIRELESS EGERT ENGINEERING, INC.

179 Greenwich Street

New York, N. Y.

Aluminum Box Shields

Beautiful Silver Dip Finish

- 5 x 9 x 6..... \$1.87
- 6 x 10 x 7..... 3.25
- 5 x 5 x 5 Knocked-down
Coil Shield (like pictured
on right) 1.00

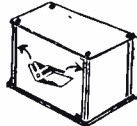

We make any size to order. Drum dial cable for Majestic, Radiolas, etc. Sponge Rubber Phone Cushions, fits all phones, 25c each; 50c pair.

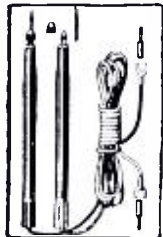

"BUDDY" Test Prod

Always sharp pointed, using phonograph needles, 4 ft. wires, spade or phone tips. Colored nipples identify each lead. 75c each. \$1.50 per pair

We specialize in radio parts exclusively - parts furnished for any kit in any magazine.

Short wave coils, \$1.75

- Alcoa Shield Plate..... 25c
- Aerovox .01 Condenser... 34c
- .0001 condensers, 15c
- .002 condensers, 15c
- 7 x 16 Aluminum Panel, 75c

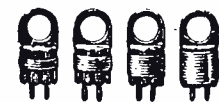

Please include sufficient postage

BLAN, The RADIO MAN, Inc.

Dept. SWC 631

89 CORTLANDT ST.

NEW YORK, N. Y.

New Transmitter Kit

THE Delft Radio Co. is marketing a kit of parts for constructing a low-loss transmitter of modern design, capable of transmitting over considerable distances. The circuit employed is the popular Hartley, which has met with such widespread approval for its simplicity and ease of adjustment.

This kit allows the amateur to assemble a good transmitting set at a small cost. A license is not required to build and experiment with a set like this, so long as one does not connect an aerial to it and actually transmit on the air. When a license is obtained, one already understands how to use it; so that going on the air is easy.

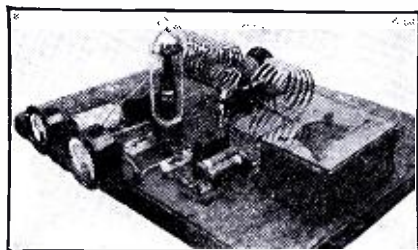

One of the features of the set is its open low-loss construction which, of course, appeals to friends who visit the amateur's shack. The parts have been cleverly chosen by experts so that one can start using the set with only a receiving tube and batteries; and later increase the power without buying new parts. The batteries from one's receiver can be used or even an inexpensive B eliminator. Power outputs up to 20 watts and more can be obtained simply by employing a larger tube and increasing the supply voltages. This transmitter can also be used for telephone.

Full instructions, written by "Ham" experts, are supplied for building the set, winding the copper-ribbon inductance.

What S-W Receiver Should I Build?

By ROLF WIGAND

(Continued from page 49)

ing regeneration coupling; and probably the simplest of these is changing the plate potential. With a high (50,000-ohm) variable resistor (RP in Fig. 3) in the plate lead one can regulate the voltage on the detector's plate and, at the same time, control the amount of regeneration.

Now it is possible, because of the very unfavorable conditions in many places of reception, that a regenerative detector is no longer sufficient to receive all stations. Even using an untuned screen-grid tube does not increase the sensitivity much. Instead of the resistor in the grid circuit (Fig. 3) we employ a tuned circuit, with which the antenna is coupled. This gives very effective R.F. amplification with good results even at locations unfavorable for reception.

To prevent self-excitation, as a result of stray couplings, it is necessary to have a careful shielding of the first tuning circuit both from the screen-grid tube and from the detector and its circuit.

Note that, at a wavelength below about 20 meters, the amplification of a screen-grid tube is less than that of an ordinary one. The disadvantage of such a receiver is that it has one more tuning control. To be sure, the tuning in the grid circuit of the screen-grid tube is very broad; but still it has to be adjusted, to get the most out of the set. Because of the effect of the antenna on tuning, ganging both tuning condensers, for single-dial operation, is not advisable. To accomplish this, another screen-grid tube will be needed for coupling to the antenna. Thus we arrive at Fig. 4, for our tuner and detector.

The shorter the wave to be received and the higher the intermediate frequency wave, the greater the practicability of the "Autodyne" method. As an intermediate-frequency amplifier, a modern screen-grid amplifier is best for this purpose; the detector is coupled to the antenna by a screen-grid tube; and a suitable audio-frequency amplifier is employed. A diagram of such a set is given in Fig. 5.

The choice of constants for such a receiver permits several options. One can give the tuning condenser a very small capacity, so that its range of variation will be slight; or shunt it by a fixed capacity, whereby the same result is attained. The latter method is therefore advisable; since changes in capacity of the entire circuit, through oscillations of the antenna, bringing the hand near, little irregularities in the construction of the tuning condenser, etc., are far less noticeable. It is advisable to use the same variable condenser for all bands, and to adjust the tuning bands by simultaneously exchanging the parallel condensers and coils. —Frank Bastler

AUTO RADIO

Long Distance Receiver

Amazing Low Price!
Quality Performance

Six tube triple screen-grid using 3-224, 2-227, and 1-245 power tube. Easy to install. Will fit any car. Single dial control. We guarantee that this set will pull in stations within a radius of 1,000 miles and that it will deliver the volume and tone qualities of an electric set, or your money refunded.

\$20

PRICE OF SET ONLY \$20.00

Price Complete, including tubes, batteries, dynamic speaker and suppressors, all ready to install and use, \$39.50. Send \$5.00 deposit with order, balance C.O.D. On foreign orders remittance in full required. ORDER TODAY.

CHAS. HOODWIN CO
4240 Lincoln Avenue, Dept. F. 170 Chicago, Illinois

This Offer Saves You \$2.00

Until the 30th of June this opportunity is yours—this chance to read radio's two great magazines, SHORT WAVE CRAFT and RADIO-CRAFT, at a saving of \$2.00.

Regularly the rate for one year's subscription to SHORT WAVE CRAFT is \$3.00 and for eight months of RADIO-CRAFT—\$2.00. For a brief period only, our readers can enter their subscription to receive both magazines for \$3.00. This is a reduction of 40% and represents a saving of \$2.00.

SHORT WAVE CRAFT you have read, and it is needless for us to say that you are well pleased and want to read every issue. It is the "Town Crier" of new developments in the short wave field.

And RADIO-CRAFT, also edited by Hugo Gernsback, is the radio magazine selected by the greatest number of service men, dealers and radiotricians. Of course, thousands of amateurs read RADIO-CRAFT, too. Each month, men of outstanding prominence in the radio field contribute articles of real interest to all. Here is a summary of articles usually found in each issue: Service Men's Department—Radio Service Data Sheets—New Developments—Radio Construction and Theory—Kinks and Information Bureau—Tubes and Their New Design—etc.

Clip the coupon NOW and mail with your remittance, check or money order will do. Postage stamps accepted in small denominations if more convenient.

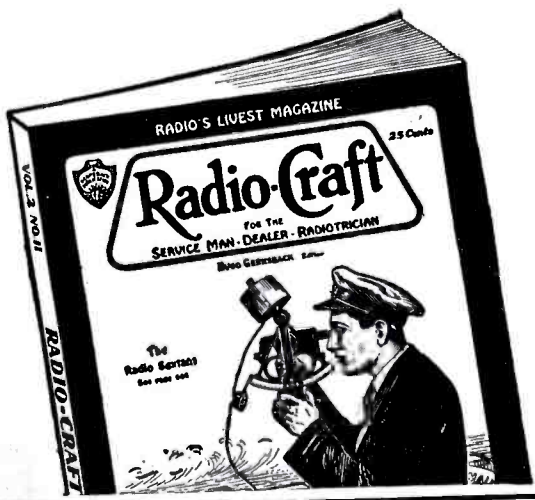

Mail Coupon TODAY!

SHORT WAVE CRAFT SWC-2-1
100 Park Place, New York, N. Y.

As per your special offer, I enclose \$3.00, for which you are to enter my subscription to SHORT WAVE CRAFT for one year and to RADIO-CRAFT for the next eight months.

Name

Address

City State

When to Listen In (Continued from page 73)

French Colonial Station

The French colonial station mentioned rather vaguely in the last issue has been more definitely identified. The call letters are FYA and the wavelength 40.73 meters. The programs will be handled by the Fédération Nationale de Radiodiffusion Coloniale. You don't have to know French to guess the meaning of this name.

* Miscellaneous Publication No. 84, ten cents in coin (no stamps) from the Superintendent of Documents, Government Printing Office, Washington, D. C. (Also see page 468 of April-May issue of this magazine for directions on how to make one.)

Switzerland

The League of Nations, which has been at the task of erecting a short-wave broadcasting station for many months, is finally expected to have the outfit in operation in a "short time". A wavelength of 15 meters will be used during daylight hours, and 35 meters at night. The station is at Geneva.

Portugal

A couple of short-wave stations are supposed to exist in Portugal, but until recently I never saw any actual reports of reception of them. A British friend reports hearing CT1AA, Lisbon, on 42.9 meters, but fails to give the schedule. As with the other European stations, it is safe to assume that it is on the air not later than about 7:00 p.m., E.S.T.

Vatican City

HVJ continues to put signals of terrific strength into most parts of the United States. The transmissions may be recognized by the opening announcement "Laudatur Jesus Christus" ("Praise be to Jesus"), and by inter-val announcements in Italian and English. Before phonograph music, the announcement "Radio Citta Vaticana" is made.

Schenectady

W2XO, one of the numerous calls assigned to the General Electric Company at Schenectady, N. Y., is evidently in use for one of the G.E. short-wave stations. A reader in South Africa reports hearing W2XO on 23.65 meters, in addition to W2XAF on 31.48.

Japan

There is no longer any doubt that a short-wave station at Tokio exists. However, reports as to its wavelength are conflicting. A New Zealand fan says he heard it on 20.5 meters, which a Londoner gives 24.8 meters. Possibly more than one wave is being used, which would not be unusual. The London listener heard the station using English over what was obviously a radio-telephone circuit, between 10:00 a.m. and noon, British time, or 5:00 to 7:00 a.m., E.S.T. If you have any "dope" on this new station, please drop me a line.

Spain

Another station whose identity and existence have been in doubt is the supposed EAR110, listed for Madrid. A listener in Pretoria, South Africa, says he heard it and gives the dial settings of his receiver, from which I judge the wavelength must be around 50 meters. However, I have seen several letters stating that no such station is on the air. I have been writing to Madrid now for almost two years in an effort to obtain some authentic information; but as yet have had no replies to any of my letters.

Denmark

There is an experimental short-wave station, OXY, at Lyngby, Denmark, transmitting on 31.6 meters. Lyngby, whether you know it or not, is a rather historical radio place; for it was from here that the famous Danish radio inventor, Waldemar Poulsen, in the year 1906, demonstrated his "talking arc". Until the development of the Alexanderson alternator, during the war, the Poulsen arc was almost the exclusive means of long distance communication; but it is now quite passé.

Just published - Moyer and Wostrel's Radio Handbook

Here at last is a handbook that meets the need for a complete digest of authoritative radio data, both theoretical and practical with one logically arranged and thoroughly indexed volume. From the fundamentals of electricity, magnetism and electron theory right down to full details on latest commercial and industrial applications, this book covers the whole field of radio, with descriptions, definitions, design data, practical methods, tables and illustrations in profusion.

886 pages of latest data on:

- television
- sound motion pictures
- modern transmitters
- latest vacuum tubes
- applications of vacuum tubes in industry
- photo-electric cells
- short-wave apparatus
- broadcast receivers
- Pieze crystal, 100 per cent modulation, etc.
- marine radio equipment, etc., etc.

See this book free. Send this coupon.

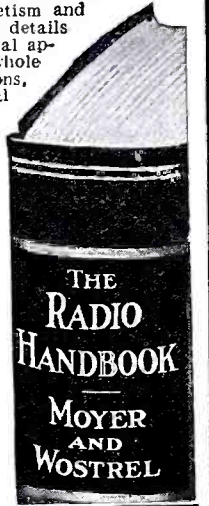

McGraw-Hill
FREE EXAMINATION COUPON

McGraw-Hill Book Co., Inc.,
370 Seventh Ave., N. Y. C.
Send me Moyer and Wostrel's Radio Handbook, post-paid, for ten days' free examination. I will send \$5.00 within ten days of receipt or return the book.

Name

Address

City and State.....

Firm

Position

SWC-6-31

BECOME A Radio Operator QUICKLY AT HOME BY CANDLER



This machine and 10 Special Tapes Furnished at Wholesale Price.

Scientific Sound Method
We teach you CODE in less than half the usual time. We've taught thousands in past twenty years, including former champion McElroy, whose speed was 56½ wpm. Our methods originated by world's foremost CODE SPECIALIST, who instructs you personally. Endorsed by officials and 45,000 Morse and Radio operators. Take up this great profession where steady jobs and rapid promotions are assured. BIG demand for CANDLER trained operators. Make a start TODAY! Send for FREE Brochure. THE CANDLER SYSTEM CO., Dept. SW-1 6343 So. Kedzie Ave., Chicago, Ill.

Makes Your Radio BEHAVE!

Free Bulletin Dept. SW-6

The New AMPERITE for electric radio improves reception—makes tubes last longer. Eliminates disturbing line voltage fluctuations. No radio can be modern without it.

AMPERITE Corporation
561 BROADWAY, NEW YORK

AMPERITE
Self-Adjusting
LINE VOLTAGE CONTROL.

Please mention SHORT WAVE CRAFT when writing to advertisers

A real Short Wave Set at a BARGAIN PRICE



HERE is a famous short wave set manufactured by Aero Products, Inc., famous throughout the world. We have a small quantity of these sets on hand, and they will be sold as long as the supply lasts. After they are gone, there will be no more.

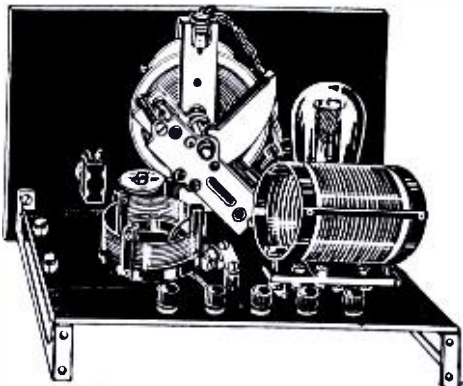

The Aero Standard Short Wave Converter for A.C. or D.C. receivers can be assembled in a few minutes and can be plugged into the detector or sometimes in the first R.F. socket of any receiver, utilizing the same tube which has been removed from the socket in which the converter is plugged. The layout and general appearance are the same as the "International" Short Wave Converter, except that the shield grid amplifier has been removed. This is the simplest converter to build and the easiest to assemble and is adapted to any receiver, regardless of type.

No. 1441—Complete "Standard" Kit for A.C. Tubes. **\$11.95**
List Price \$32.00. YOUR PRICE.....

RADIO TRADING CO.
25-A WEST BROADWAY NEW YORK, N. Y.

QUIT TOBACCO

No man or woman can escape the harmful effects of tobacco. Don't try to banish unaided the hold tobacco has upon you. Join the thousands of inveterate tobacco users that have found it easy to quit with the aid of the Keeley Treatment.

KEELEY Treatment For Tobacco Habit Successful For Over 50 Years

Quickly banishes all craving for tobacco. Write today for Free Book telling how to quickly Free yourself from the tobacco habit and our Money Back Guarantee.

THE KEELEY INSTITUTE
Dept. O-600 Dwight, Illinois



Back Number SALE!

3 Copies for \$1.00

Single Copies at Fifty Cents Each

HERE is a great opportunity to make a complete set of the issues of SHORT WAVE CRAFT—at a most sensational saving. This back number sale enables our readers to make a comprehensive file of all the latest material in the Short Wave field. These few complete books, which are easily accessible, might be used as a permanent reference.

Each issue on the newsstand sells for fifty cents per copy. This sale may be the last at such a tremendously low price of **THREE FOR ONE DOLLAR**. Of course single copies must be sold at fifty cents each. Fill in the coupon at the bottom and mail NOW! Your copies of SHORT WAVE CRAFT will be sent to you immediately.

SHORT WAVE CRAFT, SWC-2-1
96-98 Park Place, New York, N. Y.

As per your special offer, I enclose herewith One Dollar for which please send me the three issues of SHORT WAVE CRAFT indicated below:

Single Copies at Fifty Cents Each

October-November December-January
 February-March

Name

Address

City..... State.....

Results of International Short-Wave Tests

By ARTHUR J. GREEN

(Continued from page 22)

national Short Wave Club to the many contestants.

The musical part of the program included, beside several members of the Chicago Civic Opera, Scotch bagpipe players, a group of native Mexican musicians and singers, the new musical instrument called the "Theramin," and many other outstanding features. A member of the World's Fair committee broadcast a welcome to the world to take part in this exposition, which will be held in Chicago in 1933.

Awards Distributed in Many Lands

The winners of the awards were distributed throughout the world. A *Mercury* short-wave receiver was won by Mr. Ivan Omeara of Gisborne, New Zealand; a *Baird* receiver by Juan March of Mexico City; and a *Norden-Hauck* short-wave receiver by Mr. Collin Bellamy of Barbados, B. W. I. A *National S.W.* receiver was won by Miss Mary Brito of Havana, Cuba; and a *J-M-P* receiver by Kenneth Mallalieu of Trinidad, B. W. I. A *Sessions* Chime Clock went to Mr. Dudley Huston of Timarau, New Zealand. Other prize winners were Donald Parsh of Chicago; Miss Estrella Perez, San Angelo, Mexico; R. T. Stanton, Christchurch, New Zealand; Mrs. Mayiol Bayley, Barbados, B. W. I.; Sr. Jose Rivodo, Caracas, Venezuela; Arthur Threan, Virgin Islands; Victor Lopese, Havana, Cuba; E. A. Wilson, Halifax, Canada; Nicolas nin y Valiente, Havana, Cuba; G. G. Caccia, Milano, Italy; Wm. J. Boone, Honolulu, Hawaii; O. V. J. Martin, Vamlinbo, Sweden; Noel T. Wicker, Adelaide, South Australia; C. B. Dredge, Palmerstown, New Zealand, and H. F. Adcock, Masterdon, New Zealand.

This list of award winners tells the story of what a 500-watt station on short

(Continued on page 78)

SWAPPERS

SWAPPERS are swappers of correspondence. During the past few years we have noted that Short-Wave enthusiasts love to get acquainted with each other by mail in order to swap experiences.

That's the reason we have opened a department for them under the above heading, in which we will print the names and addresses of all those who wish to correspond with others. As we know we will be deluged with requests, please be sure to follow these simple rules: Use a postcard only. Never write a letter. Address postcard as follows:

SWAPPERS
c/o SHORT WAVE CRAFT
96-98 PARK PLACE
NEW YORK, N. Y.

On the blank side of the postal PRINT clearly your name, address, city and State. Don't write anything else on card. We will then understand that this is your request to publish your name and address and that you wish to enter into correspondence with other short-wave readers. There is no charge for this service.

—EDITOR.

EVERETT ARNES,
Northwood, North Dakota
MIGUEL BLANCO
71 No. 484 Mérida Yuc, Méx.
KENNETH BLOCK
870 Riverside Drive, New York City
T. D. BOYD
31 W. Louise St., Long Beach, Cal.
WILLIAM F. BOYLE
121 Shonnard Place, Yonkers, N. Y.
IRA E. BROWNE
1873 Winnebago Ave., Chicago, Ill.
LT. PAUL EUGENE CALDWELL
230 National Ave., National City, Calif.
LEWIS C. CHAPMAN, W5ZZO
Rt. 1, Box 118, Columbus, Mississippi
DAVID A. CINTRON
242 West 112th St., New York, N. Y.
D. V. CLARK, W7AHZ
Creswell, Oregon
CHESTER CLEMENS
49 Second St., Somerville, N. J.
SEAWARD DALTON
306 E. Green St., Urbana, Ill.
GEORGE S. EDWARDS
698 Dixwell Ave., New Haven, Conn.
HERBERT GEORGE
161 Rollstone St., Fitchburg, Mass.
L. C. HANNA
Bonita Springs, Florida
JOHN HEMAK
2041 21st St., Chicago, Ill.
RAY HENNING
1818 W. Grant St., Milwaukee, Wis.
CECIL HINKLEY
58 Susquehanna St., Binghamton, N. Y.
EDWARD HOLLAND
239 River St., Toronto, Ont., Can.
ALTON I. HUFFMAN
Wolf Creek, Oregon
A. S. LARSEN
Box 261, Chapman, Kansas
HILARY LINDSEY
214 S. Vine Ave., Tyler, Texas
EDWARD LORENTZ, W8ELO
400 Marshall St., McMechen, W. Va.
GEORGE LYON
Warners, N. Y.
JOHN MALONE
Lacon, Ill.
TOM MOORE, JR., W5BIO
823 North 7th St., Durant, Okla.
EDWARD MOORY
Box 311, DeWitt, Ark.
EARLING NELSON, W8AIQ
18 Ten Broeck St., Albany, N. Y.
JOHN ONUSCONAGE, W8DNL
438 E. Front St., Atlas, Pa.
ROBERT E. PADGETT
1813 Tioga St., Camden, N. J.
LEN SCHNITZERLING
Canning St., Warwick, Queensland, Australia
MARVIN W. SHELLHAMER, W8AKF
258 Brown St., Tamaqua, Schuylkill Co., Pa.
RUSSELL M. SHORT
811 West 2nd St., Weiser, Idaho
GEORGE SINCLAIR
809 E. Pine Ave., Compton, Cal.
JOSEPH M. STANIK
3585 W. 49th St., Cleveland, Ohio.
DANIEL E. STEVENS
6524 Lebanon Ave., Phila., Pa.
C. R. SWENSON
STEPHEN S. TALLMAN
738 Spring St., Hot Springs, Ark.
19 Yale Place, Rockville Center, L.I.C., N.Y.
DONALD G. TERRY
Box 226, Clinton, Mich.
DALE TISDALE
Box 221, Zearing, Iowa
EARL S. WELLER, W9GCY
224 Van Buren St., Litchfield, Ill.
CHARLES L. WOODFORD
371 Wash. St., Braintree, Mass.
FRANK L. ZIEGLER, JR.
466 East Front St., Marietta, Pa.

Our Removal Sale Special

5% off

ON ALL MERCHANDISE LISTED ON THIS PAGE AND THE HUNDREDS OF ITEMS IN OUR NEW CATALOG

SEND FOR OUR SPRING 1931 FREE CATALOG

LOFTIN-WHITE
Direct Coupled
Amplifier
245 Model



Completely wired and assembled. A.C. current. Furnishes ABC voltages to any 2 1/2-volt tuner using A.C. Uses one 24, one 45, one 80.
Price... **\$14.50**
Tubes extra.

VICTOR ABC
Power Trans-
formers

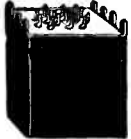

As used in Victor Sets For use with six 26's, two 45's and one 80; can also be used for any power amplifier using 245 tubes. Price **\$2.75**
25 cycle, \$3.25

QUAM
Magnetic Speaker



Improved in every respect. Housed in beautiful gold stipple finished metal cabinet, 14x12x5. Reproduction is excellent.
Price... **\$2.95**

A.C. STRATFORD
Screen Grid
6-Tube Super
Dynamic Radio
with Big Volume



Uses four 224 screen grids, one 245 power amplifier and one 280 rectifier. Perfect Rola. Dynamic Speaker included. Cabinet of walnut veneer, stands 18" high, 12 1/2" wide at base.
\$26.25
Less tubes
Kit of Arcturus matched tubes \$9.23 or RCA Licensed tubes \$3.94.

PEERLESS ABC
Power Trans-
former



Used in Courier Model 65 chassis; plate, control grid, screen grid, filament voltages for three 24's, two 45's and one 80 rectifier; 80 watts, 110-120 volts, 50 or 60 cycles. Price **\$3.25**

RCA BRUNSWICK RESISTANCES

- K-2673090 Resistor, 2450 ohms, used in RPA 4 and 4A; Part R90. 60c
- K-2673091 Resistor, 3400 ohms, tapped at 1400 ohms; used in RPA 4 and 4A; Part R91. 60c
- K-2670325 Resistor, 4000 ohms, untapped; used in RPA 1A and 4; Part R25. 60c
- K-2673067 Resistor, 407 ohms, tapped at 270 and 310; used in RPA 5; Part R67. 60c
- K-2673092 Resistor, 840 ohms, tapped at 300; used in RPA 4A; Part R92. 60c
- Bremer-Tully 510 Resistor, 4500 ohms. 60c
- K-2673031 Resistor, 1100 ohms, tapped at 300 and 400; used in RPA 3, 3A and 3B; Part R31. 60c
- K-2673044 Resistor, 1100 ohms, tapped at 200; used in RPA 7 and 7A; Part R44. 60c
- K-2673047 Resistor, 6000 ohms; used in 7 and 7A; Part R47. 60c

RCA 104 RPA (Power Loudspeaker) Transformer

An excellent transformer for direct coupled audio amplifiers; uses one 10, two 16B's (or '81's), one 874 and one 876.
Price... **\$4.85**



POLYMET Filter and By-pass Condenser

1 mfd. 600 volts. Replacement in Brunswick and Bremer-Tully sets.
Price... **45c**
\$4.80 doz.



BAL-RAD High Voltage Surge-Proof Condensers

For general repair and power pack work. Furnished in fibre container with long, flexible leads, ready for immediate installation. Impregnated in a high quality compound.



GUARANTEED 100% REPLACEMENTS

| Size | Mfd. | Work. Volts | Each | Dozen |
|-------------------|--------|-------------|------|--------|
| 5 1/2 x 2 1/2 x 1 | 1 mfd. | 800 | 35c | \$3.60 |
| 5 1/2 x 2 1/2 x 1 | 2 mfd. | 800 | 50c | 5.50 |
| 5 1/2 x 2 1/2 x 1 | 4 mfd. | 800 | 75c | 8.00 |

Brunswick, Bremer-Tully Condenser Block

For replacement in Models S81 and S82 B-T; may also be used in receivers operating on 60 cycles. Seven fixed condensers are contained in this bank. Red or green spot top.
\$1.25



STRATFORD 1,000-Volt Condensers

Highest grade voltage condenser made. 100% replacement. Individual cartons. Each has flexible leads.
Small, Compact
1 mfd... 60c
2 mfd... \$1.05
4 mfd... 1.50



BREMER-TULLY Power Transformer



Used in Models S-81 and S-82 of B. T. and in Brunswick Models S-31 and 32. Delivers current for four 24's, one 27 and push-pull 45's. Must be used with type D-126 regulator tube or equivalent ballast tube... **\$4.50**
25 cycle, \$4.75

STROMBERG-CARLSON BRUNSWICK RCA Filter Condenser Blocks



32 mfd. and used as an "A" filter on all sets.
Price... **\$3.50**

Genuine ARCTURUS Tubes
Any quantity **40% and 10% OFF**

6 MONTHS Unconditional Guarantee

PEAK RCA Licensed TUBES

The PEAK radio tube is manufactured by one of the largest tube manufacturers in the country, whose name we are not at liberty to disclose, as they do not want it known that they are selling their tubes at a cut price. These tubes are of the highest standards and sold on a "money back approval basis" if not satisfactory.

| | List Price | Our Net Price | | List Price | Our Net Price |
|---------|------------|---------------|----------|------------|---------------|
| CX-112A | \$2.25 | \$0.64 | CX-345 | \$2.00 | 0.64 |
| CX-300A | 4.00 | .64 | CX-350 | 11.00 | 1.25 |
| CX-301A | 1.25 | .52 | CX-371A | 2.25 | .64 |
| C-324 | 3.30 | .64 | CX-371AC | 2.25 | .64 |
| CX-326 | 1.75 | .64 | CX-380 | 1.90 | .64 |
| C-327 | 2.20 | .64 | CX-381 | 7.25 | 1.25 |

SPECIALS

- RCA Brunswick RPA 7 and 7A Amplifier Units... **8.85**
- Brunswick RPA 3 and 3-A Power Units... **8.85**
- Brunswick RPA 5 Power Unit and B Supply... **10.65**
- Brunswick A.C. Panel and Chassis for Superhet. Set... **6.75**
- Low Power Current Supply Transformer... **2.75**
- RCA Power Audio Amplifier Transformer... **2.75**
- Dubilier Replacement Block for Bremer-Tully Model 8-17; 5 leads; Part 1672... **1.75**
- Output Speaker Filter—RCA Part P86... **1.25**
- Stromberg-Carlson 1/2 mfd. Filter Condensers... **.25**
- Ingrad By-pass Tubular Condensers, 300 volts; sizes .02, .1, .05, .25... per doz. **1.80**
- Acrovox By-pass Condensers for Bremer-Tully 8-20A and 821A; Part 757... **.35**
- RCA Filter Condensers, 4 mfd., 600 volts; Part 1520... **1.25**
- RCA Filter Condensers, 3.5 mfd., 600 volts; Part 1514... **.90**
- RCA Filter Condensers, 2 mfd., 400 volts; Part P1520... **.60**
- Stromberg-Carlson 6 mfd., 600-volt Condensers... **1.40**
- Sangamo Filter Condensers, 2 mfd., 1,000 volts D.C. Part P568... **1.45**
- Dubilier Filter Condensers, 20 mfd., 300 volts D.C... **2.00**
- Brunswick Antenna Coil Shield for Model S31; Part 738... **.60**
- Brunswick RCA Panatrophe Phonograph Units... **.65**
- Bremer-Tully and Brunswick Audio Transformers—ratio 3 1/2 to 1... **.95**
- Brunswick and Bremer-Tully phone input transformers; Part X682... **1.25**
- Input and Interstage Transformers; Part X682... **1.25**
- Input and Interstage Transformers used as an input transformer in RPA Brunswick; RCA Part Y1102; Brunswick Part P930... **1.10**
- Centralab 25,000-ohm Volume Control with H & H toggle switch; Part X626... **1.50**
- Earl A B C Power Transformer, 70 watts, for Model 22... **1.85**
- RCA Power Transformer for Radiolas 17, 18, 33 and 51; Part 8335... **3.95**
- Replacement Power Transformer for Radiolas 44, 46 and 47; Part 8472... **4.45**
- Replacement Transformer for Radiolas 60 and 62; Replacement Part 8334, G41... **4.45**
- General Replacement Transformer for 110 volts A.C., 50-60 cycles... **2.75**
- Genuine Philco Power Transformer for Models 65, 76, 77 and 77A; Part 3516... **3.75**
- Philco Power Transformer for Model 87; Part 3400... **2.75**
- RCA Choke Coils, 15 henrys, 65 mls... **.25**
- Double Filter Chokes, RCA Replacement Part 8336... **.75**
- Mignon Audio Transformers, Junior type .75; Cub type Genuine All-American Replacement Audio Transformers with brackets and lugs... **.65**
- Muter Electric Dynamic Speaker... **8.95**
- Farrand Dynamic Speakers... **6.50**
- RCA D.C. 106 Dynamic Speaker Chassis with 600-ohm field resistance... **8.95**
- Bal-rad Replacement Blocks for Atwater Kent A.C. Model 37... **4.95**
- Victor Replacement Condenser Blocks, 10% mfd.; for all Victor sets... **2.25**
- Faradon 5.1 mfd. Kolster and Brandes Condenser Blocks; Kolster Part 4349... **.75**
- Polymet Filter Condenser Block, 3 1/2 mfd., for Stewart Warner sets... **.65**
- Pottor By-pass Condenser, 1/2 mfd., for Crosley sets... **.25**
- Crosley By-pass Condenser, 1/2 mfd., type 1107... **.25**
- Cartor Volume Control, 25,000 ohms... **.20**
- Victor Voltage Divider, 4,325 ohms, tapped at 2,000, 1,350, 775 and 200 ohms... **.95**
- Earl-Freed Volume Control for all models... **.35**
- Freed and Earl 20-ohm Hum Potentiometer... **.15**
- Westinghouse Rectox 1 amp. Trickle Charger, A.C., 115 volts, 50-60 cycles; D.C., 1 amp., 6 volts... **3.95**
- Heavy Duty Line Voltage Regulator... **.45**
- Acme B and C Eliminator... **8.00**
- United Electric Turntable, operates on 110 volts A.C... **11.75**
- A.C. Dayton Flewelling Shortwave Converter... **4.95**
- Stewart-Warner Rotary Snap Switch, 5 amp., 125 volts Heavy Duty Electric Soldering Irons... **.85**

BAL-RAD HY VOLTAGE UNCASED SURGE-PROOF CONDENSERS

For General Repair and Power Pack Work These condensers are small and compact. Impregnated in pitch with long flexible leads to facilitate making quick connections.

| Mfd. | Working Volts | Each | Dozen |
|------|---------------|------|--------|
| 1 | 600 | 30c | \$3.00 |
| 2 | 600 | 40c | 4.50 |
| 4 | 600 | 60c | 6.75 |

Each container packed in individual carton.

RCA VICTOR UNCASED CONDENSERS 1,000 Volts D.C. Working Voltage



Genuine RCA Victor uncased condensers composed of highest grade materials. Compact and moisture proof. Impregnated in heat resisting compound. Packed in individual cartons.
100% Replacement Guaranteed
1/2 mfd. .25c ea. \$2.50 doz. 2 mfd. 50c ea. \$5.50 doz.
1 mfd. .35c ea. 3.60 doz. 4 mfd. .85c ea. 9.00 doz.

FIELD COIL FOR DYNAMIC SPEAKERS



For replacement in Zenith, Peerless and Farrand and other dynamics.
Price... **\$1.25**

RCA BRUNSWICK Catacombs



6 and 8 tube panels. For amplifying units. **\$5.40**

RCA Pushpull Input and Output



A.F. Transformer Assembly for Radiola 80, 82 and 86; Part 8554.
Price... **\$1.50**

A.K. Replacement Transformer



For all battery sets and early electric sets. **\$1.50**

RCA No. 106 Dynamic Speaker Rectifier Stacks



Delivers 85 volts D.C. with load. Will supply B voltage on any dynamic speaker having 600 ohm field.
Price Each... **\$3.00**

TERMS: 20% with order, balance C.O.D. 2% discount allowed for full remittance with order only.

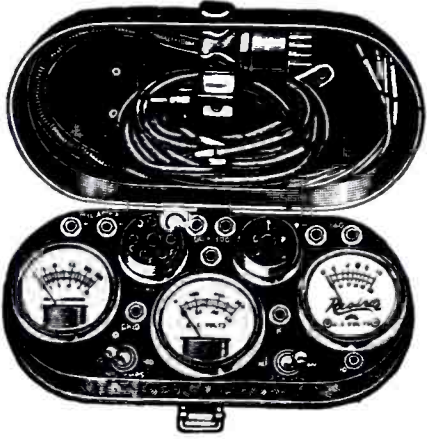

No. 245-A

Set and Tube Tester

Newly designed to meet the servicing needs of all types of radio receiving sets. Used by experts. Adaptable for every kind of socket test. Also continuity of circuits, A.C.-D.C., and all tubes including screen-grid and rectifier. Checks line voltage. Charts for resistance and capacity with full instructions furnished. Accurate. Compact. Simple to use. Durable steel case finished in beautiful baked enamel.

\$12 NET to Dealer No. 245-A
No. 400
\$20 List Each

At Your Jobber's — If not at your jobber's we will ship direct

Readrite

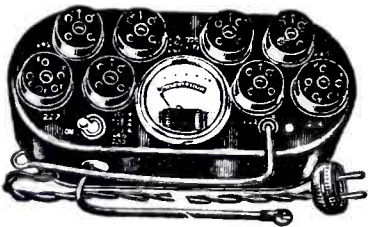

No. 400

Counter Tube Tester

A new tester that gives dealer and customer the required tube value information. Mutual conductance test all tubes, including the new 2-volt tubes. Simple to use. Accurate. Dependable. Connects to A.C. supply. Attractive baked enamel finish. All parts shielded. Complete with up-to-date tube chart.

Send for Catalog — Order Your Testers Now

Readrite Meter Works

Established 1904

17 College Ave. Bluffton, Ohio

International S-W Tests

(Continued from page 76)

waves can do in one evening. It does not, however, tell the story of how many listeners in these parts of the world heard the same program with less trouble; or else failed to give more complete details in their letters to the station. To accomplish what was done in this test shows what may be expected of short waves as a means of bringing about International Good-Will.

STATEMENT OF THE OWNERSHIP, MANAGEMENT, CIRCULATION, ETC., REQUIRED BY THE ACT OF CONGRESS OF AUGUST 24, 1912.

Of Short Wave Craft, published bi-monthly at Mt. Morris, Illinois, for April 1, 1931.

State of New York, County of New York, ss.
Before me, a Notary Public, in and for the State and county aforesaid, personally appeared Hugo Gernsback, who, having been duly sworn according to law, deposes and says that he is the editor of the Short Wave Craft and that the following is, to the best of his knowledge and belief, a true statement of the ownership, management (and if a daily paper, the circulation), etc., of the aforesaid publication for the date shown in the above caption, required by the Act of August 24, 1912, embodied in section 411, Postal Laws and Regulations, printed on the reverse of this form, to wit:

1. That the names and addresses of the publisher, editor, managing editor, and business managers are:

Publisher, Popular Book Corporation, 98 Park Place, N. Y. C.; Editor, Hugo Gernsback, 98 Park Place, N. Y. C.; Managing Editor, H. Winfield Secor, 98 Park Place, N. Y. C. Business Manager: None.

2. That the owner is: (if owned by a corporation, its name and address must be stated and also immediately thereunder the names and addresses of stockholders owning or holding one per cent or more of total amount of stock. If not owned by a corporation, the names and addresses of the individual owners must be given. If owned by a firm, company, or other unincorporated concern, its name and address, as well as those of each individual member, must be given.)

Popular Book Corporation, 98 Park Place, N. Y. C.; D. Gernsback, 98 Park Place, N. Y. C.; H. Winfield Secor, 98 Park Place, N. Y. C.

3. That the known bondholders, mortgagees, and other security holders owning or holding 1 per cent or more of total amount of bonds, mortgages, or other securities are: (If there are none, so state.)

None.

4. That the two paragraphs next above, giving the names of the owners, stockholders, and security holders, if any, contain not only the list of stockholders and security holders as they appear upon the books of the company but also, in cases where the stockholder or security holder appears upon the books of the company as trustee or in any other fiduciary relation, the name of the person or corporation for whom such trustee is acting, is given; also that the said two paragraphs contain statements embracing affiant's full knowledge and belief as to the circumstances and conditions under which stockholders and security holders who do not appear upon the books of the company as trustees, hold stock and securities in a capacity other than that of a bona fide owner; and this affiant has no reason to believe that any other person, association or corporation has any interest direct or indirect in the said stock, bonds, or other securities than as so stated by him.

5. That the average number of copies of each issue of this publication sold or distributed through the mails or otherwise, to paid subscribers during the six months preceding the date shown above is (This information is required from daily publications only).

H. GERNSBACK.

Sworn to and subscribed before me this 30th day of March, 1931.

(Seal.)

MAURICE COYNE,

(My commission expires March 30, 1932.)

PANELS TUBING & RODS

FORMICA, BAKELITE AND HARD RUBBER—STANDARD OR SPECIAL SIZES

Cut While You Wait
Drilling, Engraving and Special Work

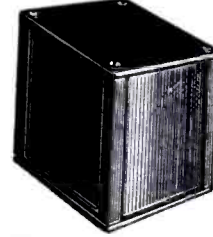

All Sizes of
ALUMINUM
CANS, PANELS
AND CHASSES
Made and Cut to
Order

Neutralizing
Screw Drivers,
Short or
Long Sizes



COUPLINGS in
Brass and Bake-
lite for 1/4 inch
Shafts

INSULATING BUSH-
INGS for all size Shafts



TEL. CORTLANDT 7-4885
Mail Orders Filled Immediately

United Radio Mfg. Co.
191 Greenwich St. New York

WORLD-WIDE SHORT WAVE RECEIVER

ONLY **\$6.45** Span the World with this Set!

A new radio thrill for you! Listen in DIRECT to London, Paris, Berlin, Buenos Aires and other broadcasting stations throughout the world via short waves. Enjoy unique foreign programs from strange lands. Your ordinary receiver cannot tune in these low wave stations. WORLD-WIDE RECEIVER gets 14 to 550 meter stations with surprising clarity. SEND NO MONEY! Just write your name and address on a postcard and ask us to send you this wonderful guaranteed short wave set. Pay postman \$6.45 plus a small delivery charge. All orders West of Rockies must be accompanied by \$1.00 deposit. Price in foreign countries \$7.75 delivered. Order today!

NEW RADIO BARGAINS

Low Power Transmitter adaptable for phone or code. With plug-in coils \$14.75
B Eliminator, Bone Dry, with 280 tube, 180 volts, will operate up to ten tube set, fully guaranteed. 6.75
AC-A B C power packs 8.75
Tubes: UX type, 30-day replacement guarantee, No. 210, \$2.25; No. 250, \$2.35; No. 281, \$1.85; No. 245, \$1.25; No. 224, \$1.25; No. 227, 75c; No. 226, 65c; No. 171, 75c.
International Microphone, two-button, for public address systems and transmitters, speech or music.. \$9.75

WRITE FOR BARGAIN CATALOG

CHAS. HOODWIN CO.

4240 Lincoln Ave., Dept. F-17, CHICAGO

PATENTS TRADE MARKS

All cases submitted given personal attention by a member of the firm.

Information and booklet free

Lancaster, Allwine & Rommel

475 Ouray Bldg., Washington, D. C.

CROSLEY Electro Dynamic Speakers

FIRST TIME SOLD AT THIS PRICE

YOUR CHOICE **\$6.50** Net

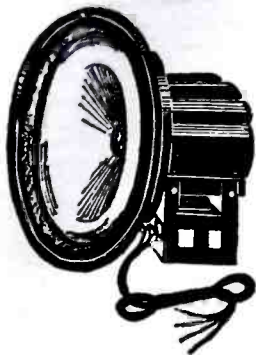

Model "A"—7" Chassis housed in beautiful metal cabinet Equipped with output transformer.
 Model "B"—Same as Model "A" Chassis only.
 Model "C"—9" Chassis with 900 ohm field and output transformer. Can be used with any set employing 1-171A or 1-245 power tube. Also can be used in Majestic Model 71.
 Model "C"—9" Chassis with 725 ohm field and push-pull output transformer.
 Model "E"—6 Volt Chassis for operation on storage battery or "A" eliminator. 85 ohm field and push-pull output transformer. Can be used with sets using the new 232 tubes. Can be converted for A.C. by use of a step-up transformer and 280 tube.

CROSLEY Type F Dynacone Speaker



This Crosley Speaker is meeting the increasing demand for an automobile radio reproducer which can be expected to give a full measure of satisfaction. Dynamic Tone!

OUR PRICE **\$2.95** Net

MUSIC MASTER Model "PETITE"

110 Volt A.C. 50-60 Cycle
THE SMALLEST
 17" x 13" x 7 1/2"
THE LIGHTEST
 Net 18 1/2 lbs. Ship'g. Weight 23 lbs.
THE MIGHTIEST
 in performance.



That, briefly describes this NATIONAL- LY and INTERNATIONALLY FAMOUS Midget Receiver. Made by a well known manufacturer. FULLY GUARANTEED to us and by us.

The chassis is a masterpiece of compact radio engineering, sturdy, clean construction. Uses three 224 screen grid, one 245 Power and one Rectifier tubes, Loftin-White amplification, Electrolytic Condensers, Magnavox or Jensen Dynamic Speaker, and all housed in a beautiful Walnut Veneer Cabinet of graceful lines.

The manufacturers' price is \$49.50 less usual trade discount.

OUR NET PRICE **\$25.45**

Optional: A set of good tubes supplied with each Receiver at \$1.25 additional. Convince yourself of the tremendous value of this offer. Order samples at once, examine and test them, your order for as many as you can handle will follow quickly.

GENERAL ELECTRIC HIGH VOLTAGE FILTER CONDENSER

3 MFD. — 800 VOLTS
 Size: 5x2 3/4 x 1 Inch.



Encased in a sturdy metal container with 8 inch flexible insulated wire leads. Equipped with handy mounting brackets.

OUR PRICE **95c** Net

\$10.00 per dozen

MAXIM "Silent" Power Supplies Reduced



DRY "B" POWER

Contains no liquids. A distinct radio bargain that will be of interest to the experienced radio buyer. (Complete with tube.) For A.C. Current.

OUR PRICE **\$6.50**

Net

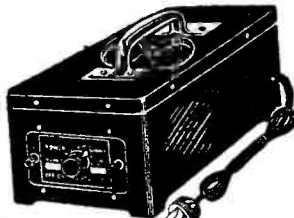

DRY "A" POWER

Regardless of price no finer "A" Power Eliminator can be procured. No need of bothering with expensive "A" batteries. Complete—for A.C. current.

OUR PRICE **\$9.00**

Net



DRY "A-B" POWER

Ultra modern design. Compact. Simple to install. Only one switch. Comes complete with a 280 tube ready to operate.

OUR PRICE **\$16.50**

Net

SONORA ELECTRIC MOTORS WITH 12" TURNTABLES

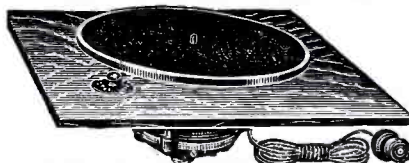

FULLY ASSEMBLED and MOUNTED

on 1/2 inch thick, warp-proof, five-ply boards, size 15 x 15, ready to install into cabinet. These motors are absolutely NOISELESS, of very rugged construction, operate on 110 volt A.C. current, and are equipped with Speed Regulator and 6 foot cord and plug. The 12" turntable will take any standard size record. By a special adjustment (at no extra cost) these motors will operate on D.C. current. Please specify when D.C. current is wanted, otherwise A.C. motors will be supplied.

An exceptional Value.

OUR SPECIAL PRICE **\$9.75**

RADIART STEP-DOWN TRANSFORMERS

INPUT 220-250 Volt 50-60 cycle A.C.
 OUTPUT 110-120 Volt, Rated at 150-160 Watt

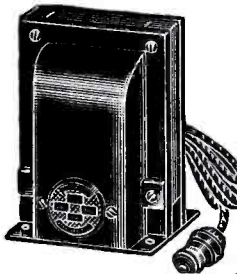

For use in localities where 220 volt, 60 cycle A.C. current is supplied. These Transformers adapt current of that voltage to any A.C. Radio or other Electrical Appliance which consumes up to 160 watts. Encased and easily mounted. Size: 4x3 1/4 x 5 1/2" Ship'g w't: 6 1/4 lbs.

VERY SPECIAL

\$3.75

List \$5.00 NATHANIEL BALDWIN RIVAL UNIT



This Nathaniel Baldwin unit is one of the finest made by that company. Can be used for Phonograph, Automobile and Portable Radio Outfits. Order your supply today before it is too late.

OUR PRICE **65c** Net

JENSEN "CONCERT" D. C. ELECTRO DYNAMIC SPEAKERS

Model D 7 D C 10" Diameter
 2500 ohm field 8 ohm voice coil

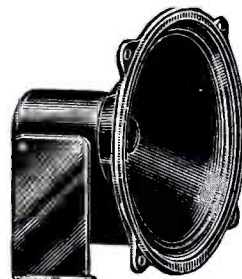

These units contain suitable push-pull transformers and are absolutely hum-free. Connect directly to the set, no outside wires.

As most standard manufactured A.C. sets are engineered for D.C. speakers of this ohmage, the possibilities for replacement with this really good speaker are practically unlimited.

The wise merchant or repair-man will take advantage of this real "buy". Never before offered at a cut price. The quantity available at this price is limited. Act quickly.

List \$27.50
 OUR NET PRICE **\$7.90**

Original factory packing of 2 in a carton.

All offers are F.O.B. New York, and subject to prior sale. Terms: A deposit of 20% is required with every order. Balance may be paid on delivery. Or, deduct 2% if full amount is sent with order.

DO NOT WRITE FOR CATALOG!

GRENPARK CO., Dept. SW, 245 Greenwich Street, New York, N.Y.

STOP! DON'T SHOP!

HERE'S a NEW plan, which saves you money. Stop shopping—the lowest prices are right on this page. Yes, lower than in our own catalog. Why? Because no house can get out a new catalog every month, but by advertising in this magazine we can bring

you the latest and lowest prices up to the time this ad is printed. We watch our competitors and do not allow anyone to undersell us. We meet ANY price on NEW merchandise. Order direct from this page and save money. 100% satisfaction on every transaction.

Dry Electrolytic Condensators

Mount in any position! Guaranteed never to blow out! Remarkably compact and very inexpensive, permitting generous use of filtering systems. The greater the mfd. capacity employed, the less A.C. hum remains. 500 volt peak rating. Ideal for all 171A - 245 power packs—use two of each capacity desired for 250 power packs (1,000 volt peak thereby assured).



| No. | Mfd. | Diameter | Length | YOUR PRICE |
|------|------|-----------|-----------|------------|
| 1801 | 1 | 3/4 in. | 2 1/4 in. | \$0.27 |
| 1802 | 2 | 1 in. | 2 1/2 in. | .44 |
| 1804 | 4 | 1 1/2 in. | 2 1/2 in. | .83 |
| 1808 | 8 | 1 3/4 in. | 4 1/2 in. | 1.20 |
| 1816 | 16 | 3 in. | 4 1/2 in. | 2.10 |
| 1824 | 24 | 3 in. | 4 1/2 in. | 2.70 |
| 1832 | 32 | 3 in. | 4 1/2 in. | 3.30 |
| 1854 | 51 | 3 in. | 4 1/2 in. | 4.73 |

Adjustable Voltage Divider



Designed for extra heavy duty. It can be used in any radio power operated set, B eliminators, power packs, amplifiers, etc. Especially useful in all radio set replacement work, used in converting battery sets into power sets. The correct voltage is obtained by loosening screws of sliders and by moving the latter into the correct position. Voltage cannot vary due to the peculiar construction of the resistor and contact sliders. Shipping weight 1/2 lb. List \$1.50. No. 2275—Divider, 10,000 Ohms, 3 slides. **75c**

No. 2276—Divider, 25,000 Ohms, 4 slides. **75c**

Peerless ABC Power Transformer—80 Watts

As used in "Courier Model 65" chassis. Plate, control-grid, screen - grid, filament voltages for three '24's, two '27's, two '45's, and '80 rectifier (electrostatic reproducer biasing potential rectifier). Has approximately the following output ratings: 2.5 V., 10 A.; 700 V., center-tapped, 350 V., and 120 Ma. on each side; 5 V., 2 A.; 3 V., 60 Ma. Primary tapped for low or high line voltage. The correct replacement for big sets. For 110-120 volts, 50 or 60 cycles. Dimensions 4x4x3 1/2 in. Weight 6 lbs. List \$12.00. **\$2.65**

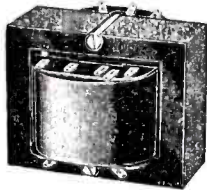

No. 1403—YOUR PRICE **\$2.65**

Kolster Speaker Chassis

May be connected directly in the plate circuit of type '12A tubes; or to higher-power tubes through an output device. In push-pull circuits, speaker may be connected from plate to plate. "9-inch cone" type. Paper-rattle is prevented by a flannel damper; bass notes are well reproduced due to the "free-edge" effect. Its small dimensions make it eligible for use in home-constructed mld g o t sets. Comes with 6 ft. cord. Dimensions: 10 x 6 1/2 x 9 1/2 inches. Shipping weight 6 1/2 lbs. List Price, \$18.00. **\$2.80**

No. 1500—YOUR PRICE **\$2.80**

A.C. Short Wave Converter

The thrill of tuning in short waves is yours, because you can connect this short-wave converter to your broadcast receiver, no matter what type receiver you have. Tunes from 10 to 200 meters, using only two plug-in coils. Coils, already wound, are supplied with outfit. Converter has built-in filament transformer to heat three 227's. All you need obtain from your receiver is a positive "B" voltage, anything from 45 to 180 volts. Voltage not critical. No molestation of the receiver. No tricky regeneration control, only a single, smooth-operating dial to manipulate. No squeals, no grunting, no body capacity. All parts for 3-tube short-wave converter, including cabinet, with filament transformer, complete instructions and pictorial diagram. Shipping weight 8 lbs. List Price \$20.00. **\$9.45**

No. 1617—YOUR PRICE, less tubes **\$9.45**

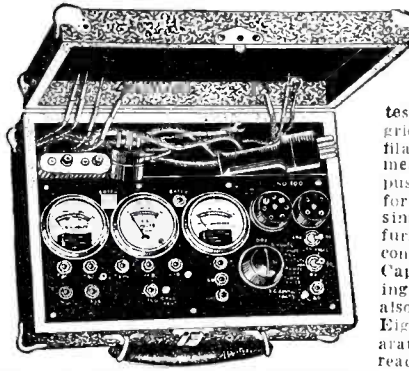

NEW READRITE Analyzer

This three-meter analyzer has selector switch for checking all parts of tube circuits by connecting to the set sockets. Selection for testing voltages of plate, grid, cathode and screen-grid done quickly and accurately. Plate current, filament volts, line and power supply volts are measured. Grid swing test for tubes used. Just push one button for screen-grid and other button for other tubes. Makes testing of all type tubes simple and thorough. 4 1/2-volt grid battery is furnished. Battery is used for grid test and continuity testing of transformers, chokes, etc. Capacity and resistance charts furnished showing use of instruments for testing condensers, also measuring resistances up to 100,000 ohms. Eight scale readings of meters may be used separately with the jack terminals provided. Scale readings are 0-60, 500-600 D.C. volts, 0-10-140. 700 A.C. volts and 0-20-120 milliamperes. A.C. and D.C. filament voltages are accurately measured on the one meter. Strong case with leatherette covering. Attractive. Compact. Complete. Fills every need for the expert serviceman or the beginner for radio set analyzing. Size 10 1/2 x 3 1/2 x 8 inches. Shipping weight 15 lbs. List Price \$25.00. **\$14.70**

R.C.A. Double Filter Chokes

This heavy-duty, extremely strong, double filter choke can be used for all types of filter circuits, experimental work, power amplifiers, receivers, eliminators, power packs, converted sets, etc. Known as R. C. A. replacement part for all Radiola models, particularly Nos. 33, 17 and 18. Each choke D.C. resistance, 500 ohms. Connected in parallel, these double filter chokes have a rating of 15 Henries at 160 MHz; connected in series, 60 Henries at 80 MHz. Fully shielded in heavy metal case with special insulating compound. Size 5 1/4 x 3 3/4 x 2 3/4. Shipping weight 6 lbs. List Price, \$10.05. **90c**



No. 8336—YOUR SPECIAL PRICE **90c**

Earl Power Transformer

Make money revamping the old battery set. This power transformer used in Earl Model 22 receiver supplies "A," "B" and "C" potentials for: two '27's (or screen - grid '24's), three '26's, two '71A's and one '80 rectifier; total current output of high-voltage winding at maximum output (about 200 volts) is 80 ma. High-voltage secondary, filament winding for '27's, and for '71A's are center-tapped. May be used in any number of combinations. Suitable resistors, a couple of 1-mf. filter condensers, two 30-henry chokes and by-pass condensers complete fine power pack. Size 3 1/4 x 3 x 2 1/4 inches. 16 long leads and full wiring directions. Shipping weight 5 lbs. List Price \$7.50. **\$1.73**



No. 1410—YOUR SPECIAL PRICE **\$1.73**

"250" A.C. Power Transformer

This power transformer supplies currents for five 15-volt Aeturus tubes drawing 5 Ma. and 1/2 amp. on filaments; one 2.5 V. tube; two '50's, and two '81's. Two 227 or 224 (if suitable resistance is used) and 750 volts. Full wave "B" and "C." Entirely shielded in metal. 4 1/4 x 3 1/4 x 6 1/2 inches high. Weight 15 lbs. For 110-120 volts, 50-60 cycles. List \$20. **\$3.75**

No. 1412—YOUR PRICE **\$3.75**

Professional Telegraph Key

Used for telegraphy, radio, home practice, house-to-house communication, as a keying means in test circuits, etc. Mounted on heavy micanite base 3 1/4 x 5 1/2 in. thick. Has 2 switches to telegraph on two circuits, independently or together. A wonderful chance to get a commercial telegraph key with sturdy 1/2-in. silver contacts! Handles a lot of power. Shipping weight 2 lbs. List price \$3.50. **70c**



No. 1625—YOUR PRICE **70c**

Utah Dynamic A.C. Power Speaker—Model 33A

110-volt, 60-cycle A.C. light socket supply for field excitation with Westinghouse dry rectifier. 9 in. high, 9 1/2 in. wide, 7 1/2 in. deep. Speaker comes packed in wooden crate. Weight 19 lbs. It is one of the most powerful as well as best reproducers in the market. 9-inch cone. List Price \$50.00. **\$7.45**

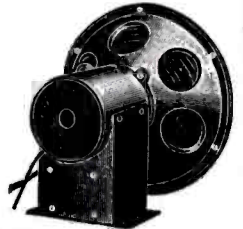

Kolster Power Transformer

Will supply sufficient current and voltage for push-pull '10's, in conjunction with type '81 half-wave rectifiers. The 2.25-volt secondary output is just below the rated maximum for type '24 and '27 tubes; tubes will last much longer than when heated from a higher-voltage transformer. Four secondaries are rated as follows: Secondary S1, 7.5 V., 1.25 A.; S2, center-tapped, 7.5 V., 1.25 A.; S3, 1.5 V., 1.25 A.; S4, 2.25 V., 1.65 A.; S5, 725 V., 90 Ma. Primary is tapped for low line voltage. For 110-120 volts, 50-60 cycles. 4 1/2 x 4 1/2 x 4 1/2 inches. Shipping weight, 12 lbs. List Price, \$19.50. **\$4.55**

No. 4336—YOUR PRICE **\$4.55**

NEW! NEW!! Superheterodyne S-W Converter

Positively greatest converter ever built. It brings in European stations daily, clear as a bell. At last a short-wave converter that converts any broadcast set into a superheterodyne short-wave receiver. Employs three 227 tubes and covers from 20 to 115 meters. No plug-in coils! Coil switch is used to cover all wavelengths. Single dial control, no body capacity, no squeals. This converter has built-in filament transformer to heat the three 227's. All you need to obtain from your receiver is a positive B voltage anywhere from 45 to 180 volts. Voltage is not critical; no molestation of the receiver. So simple a child can operate it. Size 7x10x5 inches. Shipping weight 8 lbs. No. 1614—Super Converter. List \$15.93. **\$15.93**

Price \$25. Your Price (less tubes) **\$15.93**

Genuine Magnavox Microphone

Do Your Own Home Phonograph Recording Made by the world-famous Magnavox Co. While originally made to strap on the head, it is easy to screw a handle onto one of the side brackets. The side brackets are covered with soft rubber and place the microphone at the best speaking distance from the mouth. Comes with 6 feet of cord. The biggest mike bargain in America! Complete with straps and buckle to fit around head. Brand new, in original factory packing. Shipping weight 1 lb. List Price, \$10.75. **\$1.55**

No. 1610—YOUR SPECIAL PRICE **\$1.55**

High-Voltage Condenser Units

We guarantee these condensers unconditionally. They are ideal for general replacement purposes and can be installed in any new power-pack. All condensers are furnished with 8-inch lengths of tinned "push-back" wire.

| 600 VOLTS | | | 800 VOLTS | | |
|-----------|-------------|------------|-----------|-------------|------------|
| Cat. No. | Mfd. Capac. | Your Price | Cat. No. | Mfd. Capac. | Your Price |
| 1702 | 1/2 | \$0.25 | 1706 | 1 | \$0.40 |
| 1703 | 1 | .30 | 1707 | 2 | .70 |
| 1704 | 2 | .40 | 1708 | 4 | 1.05 |
| 1705 | 4 | .60 | | | |

FREE!

NEW SUMMER EDITION

The new Summer Edition of our greatly enlarged RADIO SERVICE TREATISE has just come off the press. If you liked the Winter Issue, you will like this one a hundred-fold. It contains some 75 new hook-ups, circuit diagrams, and some 350 illustrations. POSITIVELY THE GREATEST BOOK EVER PUT OUT BY ANYONE. Among the new matters listed are:

VACUUM TUBE TREATISE, with many illustrations; full page Vacuum Tube Average Characteristic Chart; How to Take Care of Your Tubes; How to Connect Phonograph Pick-ups; Improving the Tone Quality of Old Sets; Connecting Additional Loud Speakers; all fully illustrated with diagrams.

Other articles: Modernizing Old Radio Sets; How to Convert Battery to Power Sets; Selection of Tubes; Push-Pull Amplifiers; Replacing Audio Transformers; Phono Attachments; How to Choose Power Transformers; Voltage Dividers; Wattage of Power Transformers; Selecting and Installing Replacement Parts in Radio Sets; Filter Condensers; Repairing Eliminators.

WRITE TODAY. Enclose 2 cents for postage. Treatise sent by return mail.

RADIO SERVICE TREATISE

AND RADIO BARGAIN CATALOG

FOR RADIO SERVICEMEN-RADIO TECHNICIANS-RADIO DEALERS

RADIO TRADING CO.

25 WEST BROADWAY
NEW YORK CITY

6 MONTHS GUARANTEED NEONTRON TUBES

Sold on a 6 MONTHS FREE REPLACEMENT GUARANTEE BASIS. PROVIDING TUBE LIGHTS! All tubes are carefully meter-tested before shipment, and carefully packed. Do not confuse these HIGH QUALITY tubes with any other "low priced" tubes—our low prices are possible because we do a VOLUME business!

| Choice of | Choice of | Choice of | Choice of | NEW |
|-----------|-------------|-----------|-----------|-----------|
| 226 | 112A | 245 | 222 | Choice of |
| 227 | 200-A-199UX | 280 | 210 | 230 |
| 171A | 199UV-120 | 171 | 250 | 231 |
| 201A | 224 | | 281 | 232 |

63c each 69c each 79c each \$1.58 each \$1.08 each



WE ARE A WHOLESALE HOUSE AND CANNOT ACCEPT ORDERS FOR LESS THAN \$3.00.

If C. O. D. shipment is desired, please remit 20% remittance, which must accompany all orders.

If full cash accompanies order, deduct 2% discount. Send money order—certified check—U. S. stamps.

Radio Trading Co.
25A West Broadway
New York, N. Y.

ORDER FROM THIS PAGE. You will find special prices from time to time in this magazine. Get our big FREE catalog for the greatest Radio Bargains.

Should you wish goods shipped by parcel post, be sure to include sufficient extra remittance for same. Any excess will be refunded.

NOW You Can Do It!

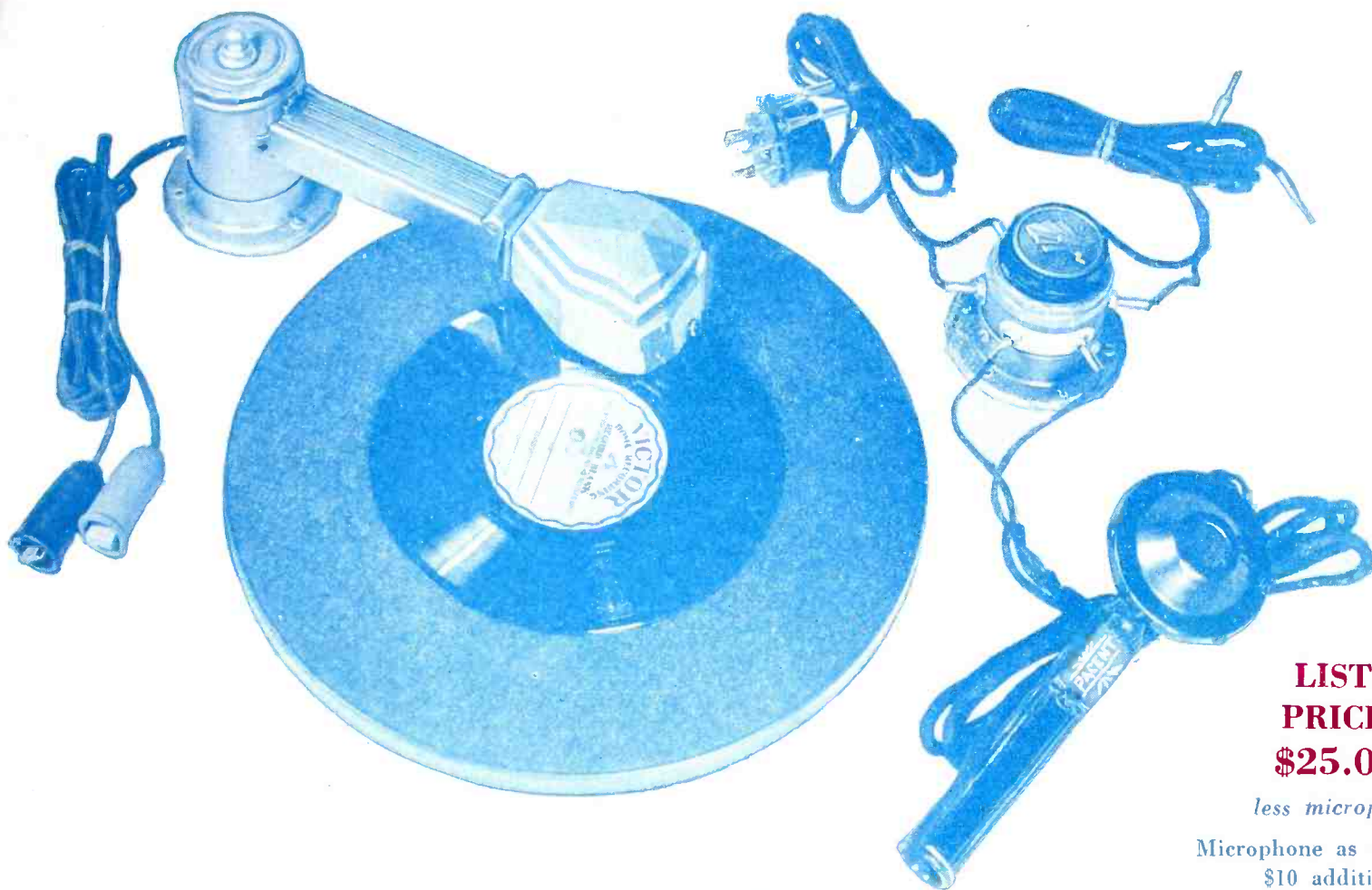

**LIST
PRICE
\$25.00**

less microphone
Microphone as illustrated.
\$10 additional

AT LAST it has become possible for every Short Wave enthusiast to actually record his messages be they code or phone.

How often have you boasted that you have received a far distant phone station, 12,000 miles away, so loud that it "rattled the gaskets of your loud speaker." But frequently your friends were highly skeptical.

Now with the PACENT RECORDOVOX, recording of any foreign program becomes child's play. And, of course, the RECORDOVOX is supreme as well for home recording, because it faithfully records and keeps for posterity the voices of the entire family.

The special blank records cost only a few cents and can be secured anywhere.

Electrically and mechanically, the PACENT RECORDOVOX is as fine an instrument as you could find even in the professional recording laboratories.

Every possible angle has been taken into consideration in the design of the RECORDOVOX. Supplied with 3 adjustable weights, it can be used with motors that lack sufficient torque to operate the turntable when the head is fully weighted. Like the well-known PHONOVOX, the RECORDOVOX, as the result of careful design, possesses excellent frequency characteristics.

Designed for pre-grooved type of records only. List Price \$25.00. Microphone \$10.00 list extra.

*Write for information on special types and models
to meet your specifications*

Manufacturers

PACENT ELECTRIC CO., INC., 158 W. 16TH ST., NEW YORK, N. Y.
Pioneers in Radio and Electric Reproduction for Over 20 Years. Licensee for Canada: White Radio, Ltd., Hamilton, Ont.

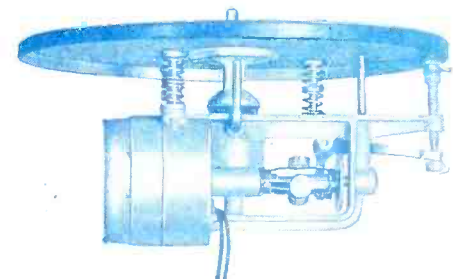

Electric Phonograph Motor, Catalog No. 140

Meets every requirement of radio-phonograph use. Has sufficient torque to cut even 10" records.

List Price \$25.00

PACENT

Pilot Achieves Radio's Greatest Sensation!

The Entire World of Radio

ON A SINGLE KNOB

15 TO 650 METERS

NO COILS TO CHANGE

The New

PILOT

UNIVERSAL SUPER WASP RECEIVER

Partly assembled "Universal" for the man who likes to "roll his own". With walnut cabinet, less tubes and speaker.

85⁰⁰

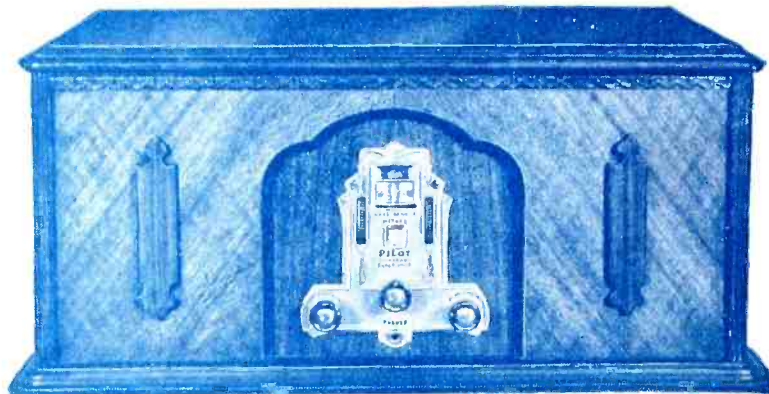

Complete "Universal" Factory assembled and laboratory tested, in walnut cabinet. Less tubes and speaker.

99⁵⁰

Pilot's wonderful wave band changing switch, incorporated in the new Universal Super-Wasp, revolutionizes the short wave art. No longer need numerous coils be changed to cover the various wave bands. No longer need dial settings change each time the same distant stations are tuned in. You can log permanently all the stations you can get throughout the world, you can tune from the short waves to the high ship waves without removing your hand from the single control knob.

Universal Features Revolutionizing the Short Wave Art

Complete coverage all wave bands from 15 to 650 meters *without coil changing*. Complete A.C. operated *chassis in cabinet*. (Also available in battery model) . . . All Metal Chassis

. . . Highly sensitive and selective circuit . . . Screen Grid TRF amplifier *plus* Screen Grid *Detector* . . . 227 First Audio Stage . . . Two 245's in push-pull output stage . . . Stations can be logged *permanently on dial* . . . Regeneration control does not alter tuning . . . Provision for *Phonograph Pick-up* . . . Earphone Jack on *Front Panel* . . . Illuminated Dials . . . Handsome Walnut Cabinet . . . Most advanced construction yet used for short wave work . . . In kit form for easy home assembly; no drilling or cutting, all parts fully prepared.

NOTICE TO "HAMS": Pilot will continue building the original Super-Wasp in kit form for licensed amateurs and others who want to spread the tuning on their pet wave bands and add their own audio features. A.C. and battery models.

PILOT RADIO & TUBE CORP., Lawrence, Mass.



Chicago: 234 S. Wells St.

New York: 525 Broadway

San Francisco: 1278 Mission Street

OFFICES IN PRINCIPAL COUNTRIES OF THE WORLD